

2.5-4  
7-711  
14-3 21 21.5 25-30

INSTRUCTION BOOK

EDDYSTONE

COMMUNICATIONS RECEIVER

TYPE 640

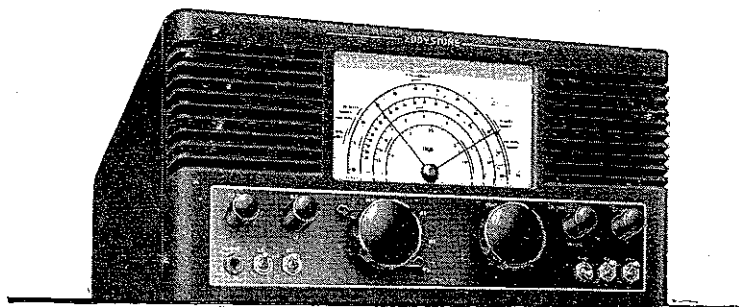

COMMUNICATIONS RECEIVER TYPE 640.

## SPECIFICATION

### GENERAL

The model "640" Receiver has been designed primarily for Amateur Communications purposes and covers, without a gap, a tuning range from 32 to 17 Mc/s. Many refinements are included in the design, which has received very careful attention to ensure that the performance shall be of a very high standard in all respects.

The following are outstanding features of the Receiver :—

- Separate Electrical Bandsread
- High Signal to Noise Ratio.
- Excellent Sensitivity.
- High Adjacent Channel Selectivity
- Large Attenuation of Image Signals
- Good Frequency Stability
- Accurate Calibration
- Efficient Crystal Filter.
- Robust Construction.

### TUNING RANGE

Three overlapping frequency ranges are provided, selection being by a low loss, low capacity switch. This is actuated by a chromium plated lever fitted beneath the left-hand large knob.

The actual frequency ranges are :—

- Band 1 32 to 12.6 Mc/s.
- Band 2 12.6 to 4.5 Mc/s
- Band 3 4.5 to 1.7 Mc/s.

Separate three-gang condensers are employed for bandsetting and band-spreading purposes. Considerable attention has been paid to the accuracy of the scale calibration, which consequently can be relied upon. Large diameter fluted knobs control the tuning mechanisms, which are smooth positive and free from backlash.

**VALVE SEQUENCE.**

The following valves perform the functions indicated in the nine valve superheterodyne circuit employed :—

V1	R F. Stage	EF39	Mullard
V2	Frequency Changer	6K8GT	Brimar
V3	1st I.F. Amplifier	EF39	Mullard
V4	2nd I.F. Amplifier	EF39	Mullard
V5	Det. A.V.C. and Audio Amp	6Q7GT	Brimar
V6	Output Amplifier	6V6GT	Brimar
V7	Rectifier	6X5GT	Brimar
V8	Noise Limiter	EB34	Mullard
V9	B.F.O.	EF39	Mullard

It will be noted that all valves are of the international octal based type, so that replacement can be made without difficulty. Points relative to each part of the circuit are discussed below. The complete circuit diagram is given in Fig. 1 to which reference should be made.

**R.F. CIRCUITS.**

The R.F. amplifier stage uses a low noise pentode, which, in conjunction with the very efficient coils, gives a high gain. The interstage and aerial couplings have been carefully adjusted to secure maximum selectivity, minimum image interference and constant sensitivity over the whole range of frequencies.

The frequency changer valve is a triode hexode of a type which possesses a high conversion factor with low inherent noise and which is particularly efficient at the higher frequencies.

The signal circuit inductances are wound on adjustable dust iron cores and trimmed with air dielectric condensers, a combination which confers two definite advantages. One is that high tuned circuit magnifications are realised, thereby increasing the overall sensitivity. The other is that tracking over the whole frequency range can be carried out very accurately.

The oscillator inductances are similar, ceramic trimmer condensers being used. The oscillator circuit is of the tuned anode type, having low harmonic content and freedom from "pulling." The oscillator volts are held near the optimum value by careful choice of circuit values and couplings.

The tuning assembly is fitted in a substantial diecast housing, ensuring complete mechanical and electrical stability. The tuned circuits retain their trim indefinitely and, after the initial warming up period, there is a complete absence of frequency drift.

**INTERMEDIATE FREQUENCY STAGES.**

There are two I.F. stages, with low noise R F pentode valves in each. The transformers are very efficient, the windings being permeability tuned and possessing high "Q" values. The units are rigidly constructed inside large brass screening cans, resulting in high stability. The intermediate frequency is 1,600 Kc/s, which enables a really good image ratio to be secured, even at the highest frequencies.

**CRYSTAL FILTER.**

Associated with the first I.F. stage is a crystal filter, the design of which is the outcome of considerable development work. The crystal itself is vacuum

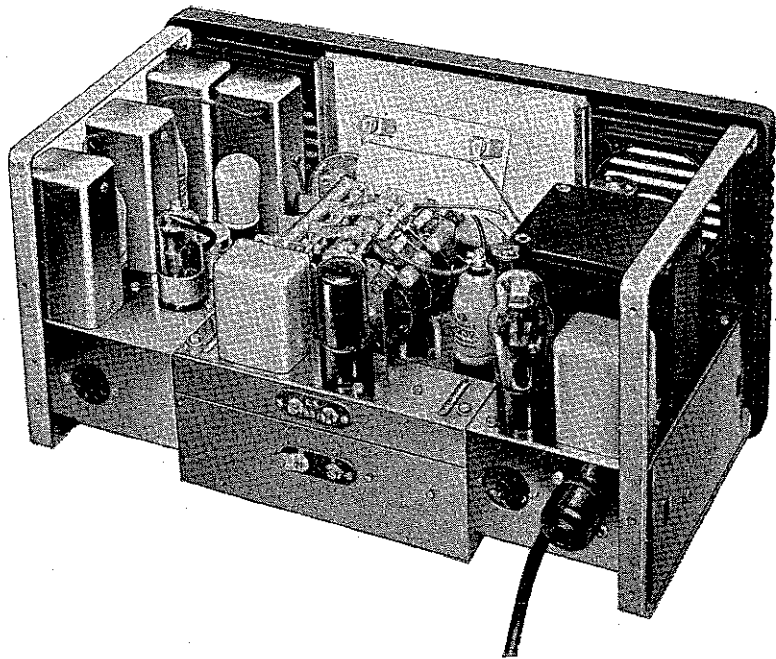

Fig 2. Plan view of "640" Receiver.

mounted, ensuring a very high "Q" value and excellent stability. It is free from spurious responses. An adjacent channel attenuation of 45 db is obtained. With proper adjustment, only slight attenuation of signal strength occurs when the crystal filter is switched in. The phasing control and in-out switch are operated from the front panel.

#### **BEAT FREQUENCY OSCILLATOR.**

This is constructed as a separate unit so that efficient screening is obtained. It is permeability tuned, has a high degree of stability and the amount of injection has been carefully adjusted for optimum results. Pitch is controlled by a variable condenser adjusted from the front panel.

#### **AUDIO CIRCUITS.**

The audio circuits follow normal practice. After initial amplification by the triode portion of the 6Q7, the signal is fed to a 6V6 beam tetrode, which is capable of delivering over 3 watts of audio power. An output transformer is incorporated and the upper terminals at the rear of the receiver are intended to take a loudspeaker with a coil impedance of about 25 ohms. The Eddystone Cat. No. 652 speaker is specially recommended.

A jack is provided for high resistance telephones, the output being attenuated to avoid overloading and to enable full use to be made of the A.F. gain control. Plugging in telephones automatically mutes the loudspeaker.

### GAIN CONTROL AND A.V.C.

The R.F. gain control R26 operates on the R.F. stage and both I.F. stages. The A.F. gain control R36 occupies the normal position between the noise limiter and the grid of the 6Q7.

The A.V.C. is applied to the R.F. stage, the frequency changer and the first I.F. stage resulting in a very good characteristic. It is of the non-delayed type in order that satisfactory indication of weak signals may be given on an "S" meter when the latter is used.

### NOISE LIMITER.

A noise limiter of the series type is incorporated and is provided with a separate panel switch. The electrical values of the components in the noise limiter have been chosen to give an efficient limiting action without unduly affecting signal strength.

### STANDBY SWITCH.

In the "off" position, this switch breaks the H.T. supply, a necessary feature when the receiver is used in close proximity to a transmitter operating in the same frequency band. Two contacts of the switch are connected to pins 3 and 4 of the octal (power) socket on the rear of the chassis and may be employed to energise a relay which, in turn, can be arranged to apply power to a transmitter, so giving complete control from the standby switch. A suitable circuit is given herewith (Fig. 3).

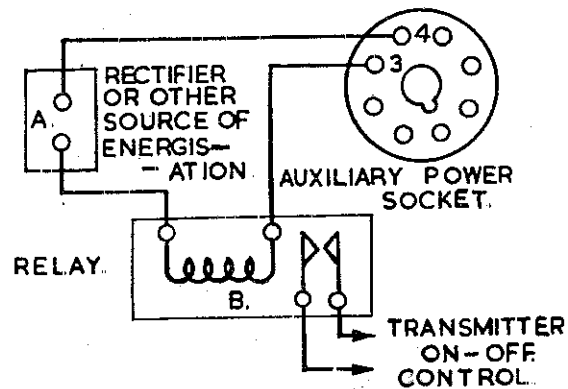

Fig 3. Circuit for use with Standby Switch

### ILLUMINATION.

The scale is evenly and adequately illuminated from the rear by two 6 volt bayonet fitting bulbs, rated at 1.8 watts each. To avoid eyestrain over a prolonged period of use, the normal brilliancy of the lamps has been reduced by the insertion of a series resistance.

### POWER UNIT.

This has been designed to provide good regulation and thorough smoothing is incorporated, the hum level being negligible.

In order that the receiver may be used under circumstances when no A.C. mains are available, provision has been made for operation from a high capacity

6 volt battery. At the rear of the chassis is an octal socket fitted with a special plug. On withdrawing this plug power supplies from a battery (for the heaters) and from a vibrator unit (or other source of H T ) may be fed into the receiver

## ELECTRICAL DATA.

### SENSITIVITY.

Sensitivity is better than 2 microvolts input for 50 milliwatts output. Because of the comparatively low noise level, very weak signals can be received with good intelligibility

Special measures have been taken to ensure even sensitivity over the whole frequency range

### SELECTIVITY.

With the crystal out, the selectivity curve shows a drop of 25 db. at 10 kilocycles off resonance. With the crystal in, selectivity is controlled by the setting of the phasing condenser and can be made extremely high for the reception of C.W. signals, with the minimum of interference.

### IMAGE ATTENUATION RATIO.

At 30 Mc/s the image is 45 db down

At 10 Mc/s the image is 60 db down.

At 2.5 Mc/s the image is 90 db down

### INPUT IMPEDANCE.

Two aerial terminals and an earth terminal are provided, enabling the use of either a single wire aerial (or feeder) or twin feeders. The aerial circuit is arranged to match into 400 ohm feeder line but good results are obtainable with aeriels widely varying in impedance.

### INPUT VOLTAGE.

Tappings on the transformer primary are brought to a selector panel at the rear. Input voltages of 110, 200 and 230 volts 40/60 cycles A.C. are allowed for. Consumption is 60 watts.

## MECHANICAL CONSTRUCTION.

### GENERAL CONSTRUCTION.

The front panel and tuning unit are aluminium diecastings, arranged to provide an extremely rigid foundation for the whole receiver. The power unit I.F. and output chassis are of brass, heavily nickel plated and securely attached to the main castings. The cover is of steel, fitted with a lift-up lid, and has been heavily rust-proofed.

### COMPONENT PARTS.

Only the most reliable component parts have been selected. They are all suitably tropicalised.

### FINISH.

The exterior of the cabinet and panel is finished a fine ripple black. The controls are surrounded by a neat finger plate, which is appropriately marked.

**VENTILATION.**

Ventilation has been carefully arranged to allow a through draught, thus avoiding any undue temperature rise

**ACCESSIBILITY.**

The receiver can be removed from the cover by the extraction of four fixing screws. The chassis is fitted with protecting rails so that, when removed from the case, it may be inverted without damage to valves or components

**WEIGHT AND DIMENSIONS.**

Weight	33 lbs unpacked
Overall Width	16 $\frac{3}{4}$ inches
Overall Depth	10 inches
Overall Height	8 $\frac{3}{4}$ inches

**INSTALLATION.**

The receiver has been carefully aligned and calibrated, and thoroughly tested before despatch. The only adjustment that may be necessary is the mains input voltage. The screw in the rear selector panel is fitted normally in the 230 volt position, where it should remain for voltages between 220 and 250 volts. If the mains voltage is between 195 and 215 volts, the screw should be changed to the 200 volt position. The 110 volt tap is suitable for mains supplies between 100 and 125 volts. D.C. mains supplies are entirely unsuitable for use with this receiver and if connected, will cause serious damage. Ensure that the octal plug is in place in the octal socket near the voltage selector panel as shown in Fig 4

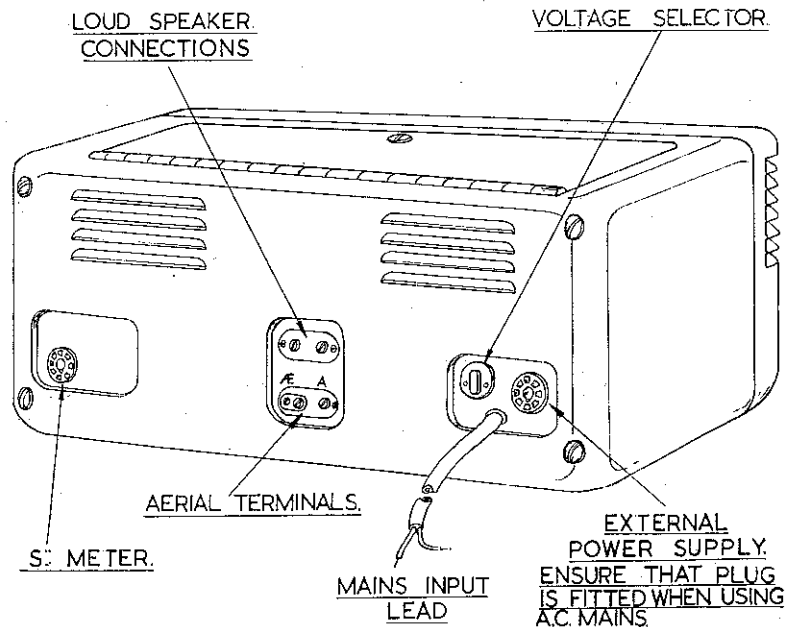

Fig 4. Rear outline of Receiver, indicating external connections

A loudspeaker of 2.5 to 3 ohms impedance should be connected to the two upper terminals at the rear (the Eddystone Cat. No. 652 is specially recommended for use with this receiver), or alternatively high resistance (2,000 to 4,000 ohms) telephones plugged into the jack at the left of the front panel

#### AERIAL CONNECTIONS.

If a single long wire is used, or any aerial with a single wire type of feeder, connection is made to the lower rear terminal marked "A", the other terminal, marked "E" remaining strapped to the chassis. A good earth, with a short lead connected to the second terminal, will improve results, particularly on the lower frequencies, but if there is any doubt about the efficiency of the earth, it may be better to leave it off — trial and error is the best expedient.

For optimum performance, both as regards bringing in weak signals, and for keeping noise down to a minimum, an aerial cut to resonate over the frequency band in which the user is mainly interested is strongly recommended. A twin feeder line, arranged to have a characteristic impedance of 400 ohms, should be taken from the centre of the aerial and the ends connected to the two aerial terminals in the receiver, after removing the shorting strap. Details of special aerials and feeders will be found in Handbooks dealing with these specialised subjects

### OPERATION.

A receiver of this type requires some experience if maximum results are to be secured and the following instructions will be found helpful.

#### PANEL CONTROLS

All controls are neatly arranged on the front panel. They comprise:—

Main Tuning	B.F.O. on-off Switch
Bandspread Tuning	Crystal Phasing
Band Selector	Crystal in-out Switch
R.F. Gain	Noise Limiter on-off Switch
A.F. Gain	A.V.C. on-off Switch
B.F.O. Pitch	Standby Switch
	Mains on-off Switch

#### BAND SET AND BAND SPREAD CONTROLS.

The left hand large knob actuates the larger (bandsetting) ganged variable condenser, the indication being given by the cranked pointer against the appropriate calibrated scale. The various amateur bands are picked out by means of a green line on the actual scale, which green line is extended to the outer part of the dial, to enable more accurate bandsetting of the amateur bands

The right hand large knob controls the smaller or bandspread condenser, through a flywheel mechanism, giving a very smooth drive. The inner pointer is read off against the outer scale, which is marked in divisions

For general purpose use, the bandspread pointer should be set at zero degrees, which is purposely offset 10 divisions to the right, to allow of adjustment each side of zero. Tuning is then carried out with the left hand knob, the pointer accurately indicating the frequency to which the receiver is set. Once the desired signal has been tuned in, vernier adjustment can be made with the bandspread knob.



For reception on the amateur bands, the band set pointer should be made to coincide with the **left hand** edge of the green line, using the outer extended scale for this purpose. Thereafter, tuning, on all but the lowest frequency band, is carried out on the bandspread scale, the high frequency end of the band being at zero, and the low frequency end well towards the right hand side of the scale. On 1.8 Mc/s, the band set knob gives adequate control, the other knob again coming in useful for vernier adjustment when necessary. If the bandspread condenser only was used on 1.8 Mc/s it would be necessary to make three adjustments of the band set condenser for full coverage. The bandspread coverage for each of the amateur bands is as follows:—

Band	Number of Scale Divisions
28 — 30 Mc/s	45
14 — 14.4 Mc/s	66
7 — 7.3 Mc/s	51.5
3,500 — 3,635 Kc/s	32
3,685 — 4,000	52

#### RECEPTION OF TELEPHONY.

The panel controls should be set as follows:—

A.V.C.	"on"
B.F.O.	"off"
Crystal	"out" (to the left)
Phasing Knob	white spot at top
R.F. Gain	full on
A.F. Gain	about two thirds on

With the range switch set to the required band, tuning is then carried out as explained previously.

#### RECEPTION OF C.W.

Panel controls:—

A.V.C.	"off"
B.F.O.	"on"
Crystal	"out"
Phasing Knob	white spot at top
R.F. Gain	near maximum
A.F. Gain	near maximum
B.F.O. pitch control knob	White spot slightly to one side of centre

Then tune normally, varying the settings of the R.F. and A.F. gain controls for maximum signal intelligibility.

#### USE OF CRYSTAL FILTER.

The controls will be as above for C.W. operation. On switching in the crystal, it will be noted that the noise level decreases somewhat, due to the increased selectivity permitting a narrower band of frequencies to pass. Rotation of the phasing control will result in the suppression of signals to a degree dependent upon their frequency separation from the desired signal. An attenuation of 20 db can be obtained when the interfering signal is 400 cycles away, this figure rapidly increasing as the separation increases.

#### FINE POINTS OF OPERATION.

It will rarely be necessary to use the full R.F. gain when receiving C.W. signals and it is well to back off this control when possible, keeping the A.F. gain

fully on. By this means, interference and noise are both reduced and intelligibility increased.

The reverse is the case when receiving telephony. The R.F. gain should be at maximum, to enable the A.V.C. system to work efficiently, and the audio output should be adjusted entirely by means of the A.F. gain control.

On rotating the B.F.O. knob, two positions of maximum noise will be noted, and these are the correct operating points. Another method of accurately setting B.F.O. pitch is to tune in a telephony station with the B.F.O. switched off. Then switch on the B.F.O. and rotate the knob so that the carrier beat is heard as a note pleasing to the ear, representing a frequency of between 400 and 1,000 cycles.

The B.F.O. pitch control may be set either side of zero beat — if an interfering signal is present, moving from one side to the other will probably reduce its strength. If car ignition or electrical interference of a peaky nature is experienced, switch on the noise limiter when the noise will drop to small proportions. Under normal circumstances, the noise limiter may be switched off. It is equally effective for C.W. or telephony reception.

Should the A.V.C. be switched on inadvertently when receiving C.W. the sensitivity will be abnormally low.

#### OPERATION FROM BATTERIES.

It will be necessary to wire up an octal plug in the following manner, assuming that H.T. will be derived from a vibrator unit.

Pins 2, 5 and 6	Blank
Pin 1	H.T. positive
Pins 3 and 4	Blank (unless used for other purposes)
Pin 7	L.T. "live"
Pin 8	L.T. "cold" (and earth, if used)
Pin 8	H.T. negative.

The battery supply must also, of course, be fed into the primary side of the vibrator unit with an external on/off switch.

The L.T. supply required is 6 volts 2.5 amperes. The H.T. supply should deliver up to 80 mA at 250 volts and may not necessarily be smoothed, since the internal smoothing will automatically be brought into circuit. Good results are obtainable with an H.T. voltage less than 200.

#### ALIGNMENT INSTRUCTIONS.

The following instructions are based on the assumption that the receiver has suffered no major misalignment and only requires a routine readjustment.

Although minor adjustments may be carried out without them, it is definitely much more satisfactory to use proper test instruments, the following being essential:—

- I A Signal Generator, fitted with a calibrated attenuator and having internal modulation. The frequency range should cover that of the receiver (32 to 1.7 Mc/s) and the intermediate frequency (1.6 Mc/s). Should the output leads not shew D.C. continuity, a 1 megohm resistor should be connected across them. For the sake of brevity, the Signal Generator is referred to in the following notes as the S.G. When aligning the R.F. stages, a dummy aerial, suitable for high

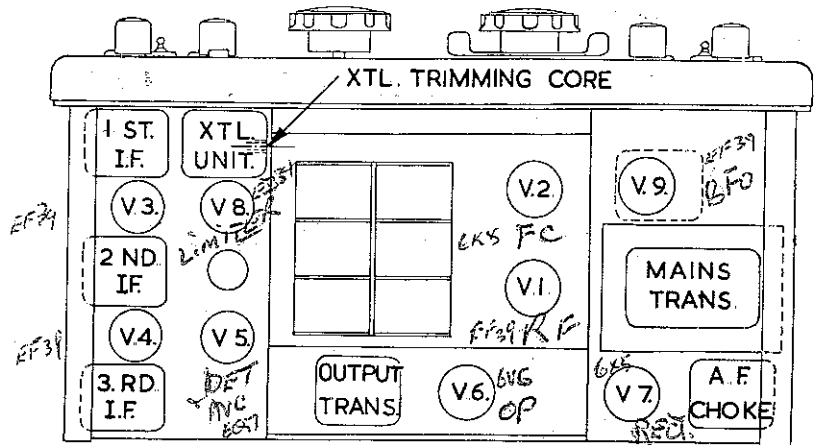

Fig. 5. Plan view in outline.

frequencies, should be interposed between the direct output of the generator and the aerial terminals of the receiver. Should no dummy aerial be supplied with the generator, a 400 ohm carbon resistor will serve, fitted in series with the high potential lead.

- 2 An audio output meter, calibrated in milliwatts and decibels, and adjustable to match an impedance of 2.5 ohms
- 3 A non-metallic trimming tool, with a screwdriver shaped end, for adjusting coil cores, etc The Eddystone Cat. No. 122T tool is suitable

Very few Signal Generators have an accuracy of calibration better than 1% and if it is desired to make an accurate check of the receiver calibration, a Crystal Frequency Standard, incorporating 1,000 Kc/s and 100 Kc/s crystals of close tolerance, is necessary.

The receiver should be removed from its cabinet (by unscrewing the four screws at the rear) and stood on its lefthand end, face to the operator. Connect the output meter across the speaker terminals, leaving the speaker connected, as this is helpful.

#### I.F. AMPLIFIER.

The nominal intermediate frequency is 1,600 Kc/s. The actual frequency is controlled by the crystal, which is ground to a tolerance of plus or minus 2 Kc/s.

The panel controls should be set as follows:—

A.V.C Switch	off	Crystal Switch	In
B.F.O Switch	off	A.F Gain	Maximum
Noise Limiter	off	R.F. Gain	as necessary

Band Spread Pointer at zero

Band Set Pointer at 13 Mc/s, Range 1

Crystal Phasing Condenser at half mesh.

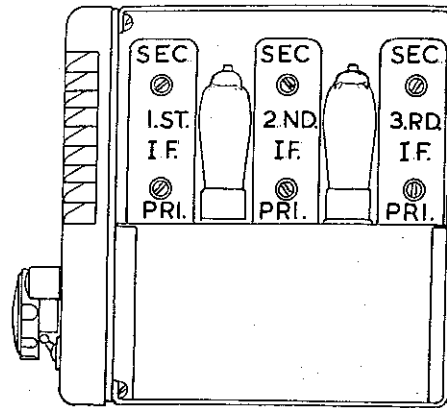

Fig 6. Location of I.F. Transformer Cores

Remove the clip from the top cap of the 6K8 valve and connect the S.G. leads between the top cap and chassis. Switch on the internal modulation in the S.G. and set the attenuator to give an output of about 100 microvolts. On swinging the S.G. dial around 1,600 Kc/s, a sharp upward deflection of the output meter will occur, indicating crystal resonance, and fine adjustment should be made to secure maximum deflection, reducing the R.F. gain if necessary. Then adjust the seven cores for maximum indication, commencing with the core in the crystal unit (accessible from the side, after removing the right hand lampholder — see Fig 5), following up with the primary of the first I.F. transformer and on to the secondary of the third transformer. Repeat this process several times, paying particular attention to the crystal core and the first transformer secondary core. The setting of the S.G. should be checked occasionally, to ensure that its frequency is exactly in resonance with the crystal.

Next check the phasing control. With an output of about 120 microvolts from the S.G., reduce the R.F. gain until the output meter indicates 500 milliwatts. Carefully rotate the S.G. dial *clockwise* until the needle falls to a 50 milliwatt indication. It should now be possible by adjustment of the phasing control to cause the output to fall to zero and this shews that the crystal is phasing correctly on one side. To check the other side, first return to the original positions of phasing control, S.G. dial setting and receiver output. Then turn the S.G. dial *anti-clockwise* until the output meter again shews 50 milliwatts. Adjusting the phasing control should have the same effect as before.

#### B.F.O. ADJUSTMENT.

To set the B.F.O. precisely, retune the S.G. to exact resonance, switch off the S.G. internal modulation, reset phasing control to half mesh and set the B.F.O. pitch control condenser also to half mesh. With the B.F.O. switched on, adjust the core in the B.F.O. unit to zero beat.

#### R.F. STAGES.

The panel controls should initially be set as follows:—

A.V.C. Switch	off	Crystal	Out
B.F.O. Switch	off	A.F. Gain	Maximum
Noise Limiter	off	R.F. Gain	as necessary

The bandspread pointer will normally remain at zero and tuning carried out with the bandset knob, but occasional use of the bandspread control may be necessary. Replace the clip on the top cap of the 6K8 valve and connect the S.G. leads (via the dummy aerial) to the aerial input terminals.

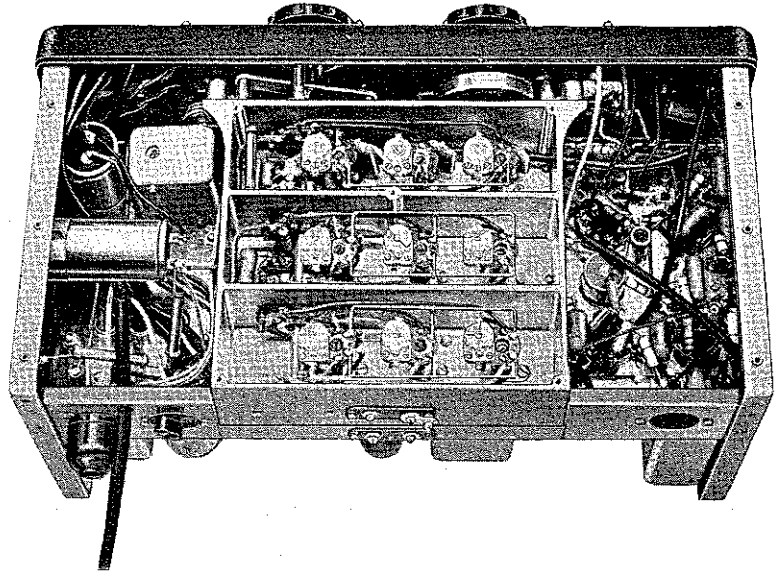

*Fig 7 Photograph of the underside of the Receiver  
Compare with Fig 8 for identification of trimmers, etc.*

To begin with, inject a signal on 30 Mc/s from the S.G. and tune it in on Range 1 of the receiver. If the calibration is out, it may be corrected by adjustment of Trimmer No. 3 (see Fig. 8). Then tune the receiver to 13 Mc/s and inject this frequency from the S.G. Any error of calibration should be corrected by adjustment of Core No. 3.

Next, repeat this procedure on Range 2, adjusting Trimmer No. 6 at 12 Mc/s and Core No. 6 at 5 Mc/s. On Range 3, adjust Trimmer No. 9 at 4 Mc/s and Core No. 9 at 2 Mc/s.

If a Frequency Standard is available, the receiver calibration may now be set more accurately. Remove the S.G. leads and substitute those from the Frequency Standard. Switch on the B.F.O. and set the pitch control knob with the white spot at the top. On tuning through the 30 Mc/s mark on the receiver dial, a harmonic from the Frequency Standard should be audible and should be tuned to zero beat. Correct any calibration error as before, by adjusting Trimmer No. 3.

Then locate the 13 Mc/s harmonic and adjust Core No. 3. The same procedure should be followed on the other ranges, using the frequencies mentioned above. Adjust the Trimmers at the high frequency end and the cores at the low frequency end of the band. Since the adjustment of one will slightly affect the other, the process should be repeated until no further improvement in the accuracy of calibration is possible. Once the two major points are correctly set, it will be found that intermediate points will check against the Frequency Standard with a high degree of accuracy.

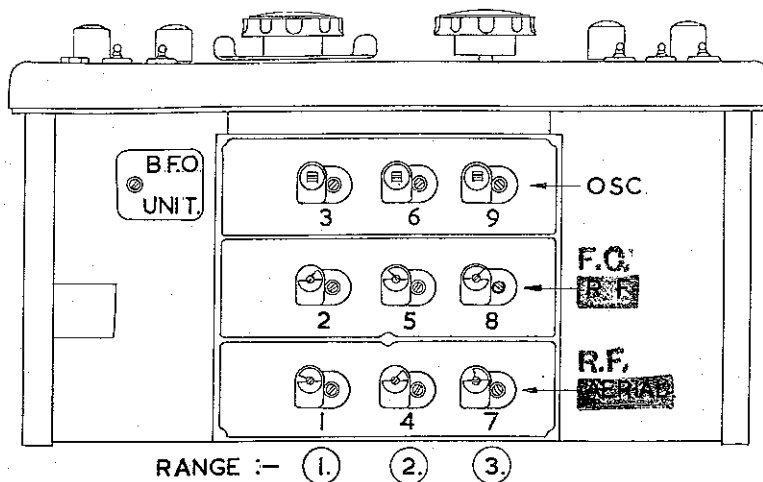

Fig. 8. Location of R.F. Trimmers, etc

This completes the alignment of the oscillator stages and the next process is to re-align the R.F. and F.C. stages. The Frequency Standard is removed and the S.G. connected up in its place, with the internal modulation switched on. Switch off the B.F.O. and tune in accurately a 30 Mc/s signal from the S.G., using first the bandset control and making a final adjustment with the bandspread knob. The R.F. gain should be well advanced and the S.G. attenuator set so that a half scale deflection results on the output meter. Careful adjustment of Trimmers Nos. 1 and 2 should now be made to secure maximum output, reducing R.F. gain if necessary.

Next, inject a signal on 13 Mc/s, tune in accurately, and adjust Cores Nos. 1 and 2. The whole process should be repeated at least once, to ensure maximum gain.

Ranges 2 and 3 are dealt with similarly, the frequencies and trimmer and core numbers being set out below for easy reference.

	Range	Frequency	Osc	F.C.	R.F.
TRIMMERS	1	30 Mc/s	3	2	1
	2	12 Mc/s	6	5	4
	3	4 Mc/s	9	8	7
CORES	1	13 Mc/s	3	2	1
	2	5 Mc/s	6	5	4
	3	2 Mc/s	9	8	7

### A.V.C. ACTION

To check that the A.V.C. system is functioning correctly, set the receiver for telephony reception — A.V.C. switch on, crystal out, B.F.O. off, R.F. gain at maximum — and inject a weak modulated signal (on any frequency within the range of the receiver) to give a small indication on the output meter. On increasing the strength of the injected signal, the output meter should at first indicate a rapid rise in output but beyond a certain point (the "knee" of the A.V.C. curve) the increase should be comparatively slow.

### SIGNAL STRENGTH METER

Connections for an "S" meter have been brought out to a socket at the rear of the receiver (see Fig 4). The wiring to the socket is shown in the circuit diagram Fig. 1 and the wiring of the meter unit is given in Fig. 9

It will be noticed that one diode of V8 is in series with the "S" meter. This method of connection prevents reverse current flowing through the meter when the R.F. gain is reduced, thereby upsetting the normal balance of the circuit. The "S" meter can therefore be left in circuit at all times without possibility of damage

The full scale deflection of the "S" meter is 200 microamperes. Normally, the bottom bend characteristic of the series diode will result in sluggish meter action at low signal strengths. To overcome this the needle of the meter should be set back about  $\frac{1}{8}$ th inch below zero by means of the mechanical zero adjuster, with the receiver switched off. Then, with the receiver functioning normally for telephony reception and with the aerial and earth terminals shorted, the "S" meter needle should be set to zero by means of the electrical balance control

The following arbitrary scale of current through meter against "S" strengths is based on a figure of 6 db change per unit:—

S1	7.5	microamperes
S2	16	"
S3	27	"
S4	41	"
S5	58.5	"
S6	77	"
S7	100	"
S8	125.5	"
S9	157	"

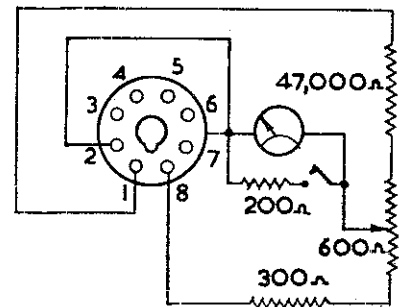

Fig 9. Circuit of "S" meter.

### SERVICING.

When a multi-range test meter is available the accompanying chart giving details of the voltages which should be found at the points indicated in Fig. 1, will prove an invaluable aid to the quick location of any fault which may arise

Under normal working conditions, a red glow can be seen from all the valve heaters, with the possible exception of the EB34 (V9), so that a valve failure should be self-evident. Failure of the EB34 will result in the "S" meter (if used) becoming inoperative and no signals will be audible with the "N.L." switched to "on."

A rough method of fault location is to touch in turn the exposed valve top caps, commencing with the 6Q7 (V5). Touching this valve, with the A.F. gain well up, should result in a loud hum being audible, absence of this indicates that the fault lies in the audio amplifier section of the receiver, including the output transformer. If the hum is obtained, touching the other top caps should cause at least a click to be heard and if, on touching one particular valve, no sound is evident, it is likely that the fault lies between that valve and the adjacent good one.

A gradual deterioration in performance will probably be due to the falling off in emission of one or more valves and, in the absence of valve testing equipment there is no alternative but to substitute a new valve in turn in each position. Provided a similar type is used to the original in the R.F. and I.F. stages, retrimming should not be necessary.

The dial lamps are easily changed by pressing and withdrawing the spring clip which holds them in place. The lamps are of the miniature bayonet type, rated at 6.3 volts, 1 watt.

#### VOLTAGE VALUES.

Voltages are between the point indicated and chassis. The Receiver should be set at 14 Mc/s on Range 1 with the aerial shorted out, R.F. and A.F. gain controls at maximum, crystal, noise limiter and B.F.O. switched off. Two sets of values are given, using different meters as shown. It will be evident that the actual voltage indicated depends upon the particular meter employed. A tolerance of plus or minus 5% should be allowed on the figures given.

Circuit Ref.	Weston	Avo.
	1,000 ohms/volt	Model 40
A	200	190
B	70	60
C	3.0	2.75
D	225	200
E	85	85
F	4.1	3.8
G	75	70
H	200	190
J	75	60
K	3.0	2.75
L	200	190
M	85	70
N	2.2	2.1
O	75	40
P	1.4	0.8
Q	217	215
R	225	225
S	10.5	10
T	95	90
U	225	225
V	250	250



## COMPONENT VALUES

RESISTORS			RESISTORS		
R1	1 Megohm.	$\frac{1}{2}$ Watt	R21	100 ohms.	$\frac{1}{2}$ Watt
R2	4,700 or 5,000 ohms	$\frac{1}{2}$ "	R22	560 or 500 ohms	"
R3	15,000 ohms	"	R23	47,000 or 50,000 ohms	"
R4	27,000 or 30,000 ohms	"	R24	400 ohms.	"
R5	4,700 or 5,000 ohms	"	R25	330 or 300 ohms.	"
R6	1 Megohm.	"	R26	10,000 ohms. pot	"
R7	4,700 or 5,000 ohms	"	R27	1 Megohm.	"
R8	1 Megohm.	"	R28	47 or 5 Megohms.	"
R9	4,700 or 5,000 ohms.	"	R29	4,700 or 5,000 ohms	"
R10	27,000 or 30,000 ohms	"	R30	47 or 5 Megohms	"
R11	.27 or .25 Megohms	"	R31	47 or 5 Megohms.	"
R12	.47 or .5 Megohms	"	R32	.27 or .25 Megohms	"
R13	400 ohms.	"	R33	270 ohms.	"
R14	.47 or .5 Megohms.	"	R34	1.0 Megohm.	"
R15	22,000 or 20,000 ohms	"	R35	2.2 Megohms.	"
R16	.47 or .5 Megohms	"	R36	.5 Megohm. pot.	"
R17	.47 or .5 Megohms.	"	R37	47,000 or 50,000 ohms	"
R18	330 ohms	"	R38	22,000 or 25,000 ohms.	"
R19	47,000 or 50,000 ohms	"	R39	3,300 ohms.	"
R20	12 ohms	"	R40	33,000 ohms.	"
			R41	2.6 ohms approx	"
CONDENSERS			CONDENSERS		
C1	3—20 pf	Air Trimmers.	C38	Crystal Phasing Condenser.	
C2	20 pf.	Ceramic Cartridge	C39	20 pf.	Ceramic Cartridge.
C3	3—20 pf	Air Trimmers	C40	200 pf.	Silvered Mica.
C4	3—20 pf.	Air Trimmers.	C41	.01 mfd.	Tubular Paper
C5	12—366.5 pf	Bandset. 3 Gang.	C42	200 pf	Silvered Mica.
C6	9—46.2 pf.	Bandspread. 3 Gang	C43	200 pf.	Silvered Mica.
C7	100 pf.	Silvered Mica.	C44	.01 mfd.	Tubular Paper.
C8	.01 mfd.	Tubular Paper	C45	200 pf	Silvered Mica.
C9	.01 mfd.	Tubular Paper	C46	200 pf	Silvered Mica.
C10	.01 mfd.	Tubular Paper.	C47	8 mfd.	Tub. Electrolytic
C11	20 pf.	Ceramic Cartridge.	C48	.0005 mfd.	Moulded Mica.
C12	3—20 pf	Air Trimmers.	C49	40 pf.	Ceramic Cartridge
C13	10 pf.	Ceramic Cartridge.	C50	01 mfd.	Moulded Mica
C14	6 pf.	Ceramic Cartridge	C51	.002 mfd.	Moulded Mica.
C15	3—20 pf.	Air Trimmers.	C52	01 mfd.	Tubular Paper.
C16	3—20 pf.	Air Trimmers.	C53	.01 mfd.	Tubular Paper.
C17	12—366.5 pf	Bandset. 3 Gang.	C54	.01 mfd.	Tubular Paper.
C18	9—46.2.	Bandspread. 3 Gang.	C55	01 mfd.	Tubular Paper.
C19	100 pf.	Silvered Mica.	C56	01 mfd.	Tubular Paper.
C20	.01 mfd.	Tubular Paper	C57	.01 mfd.	Tubular Paper.
C21	.01 mfd.	Tubular Paper	C58	40 pf	Ceramic Cartridge
C22	.01 mfd.	Tubular Paper.	C59	40 pf	Ceramic Cartridge.
C23	.01 mfd.	Tubular Paper.	C60	.0005 mfd	Moulded Mica
C24	100 pf.	Silvered Mica.	C61	25 mfd.	25 V. Tub. Electrolytic
C25	100 pf.	Silvered Mica.	C62	.01 mfd	Tubular Paper.
C26	3—20 pf.	Ceramic Trimmer.	C63	25 mfd	25 V. Tub. Electrolytic
C27	2.100 pf.	Silvered Mica.			
C28	3—20 pf	Ceramic Trimmer	C64	1 mfd.	Tubular Paper
C29	950 pf	Silvered Mica.	C65	.01 mfd.	Tubular Paper.
C30	3—20 pf.	Ceramic Trimmer.	C66	3 pf.	Ceramic Cartridge.
C31	380 pf.	Silvered Mica.	C67	200 pf.	Silvered Mica.
C32	12—366.5 pf	Bandset. 3 Gang.	C68	B.F.O. Pitch Control.	
C33	9—46.2 pf.	Bandspread. 3 Gang	C69	100 pf.	Silvered Mica.
C34	.01 mfd.	Tubular Paper.	C70	01 mfd.	Tubular Paper
C35	200 pf	Silvered Mica.	C71	.01 mfd.	Tubular Paper.
C36	400 pf.	Silvered Mica.	C72	8 mfd.	Tub. Electrolytic.
C37	400 pf.	Silvered Mica.	C73	16 mfd.	Tub. Electrolytic.



Published by

**STRATTON & CO. LTD.**  
**WEST HEATH**  
**BIRMINGHAM 31**

Sole Manufacturers of Eddystone Radio Products

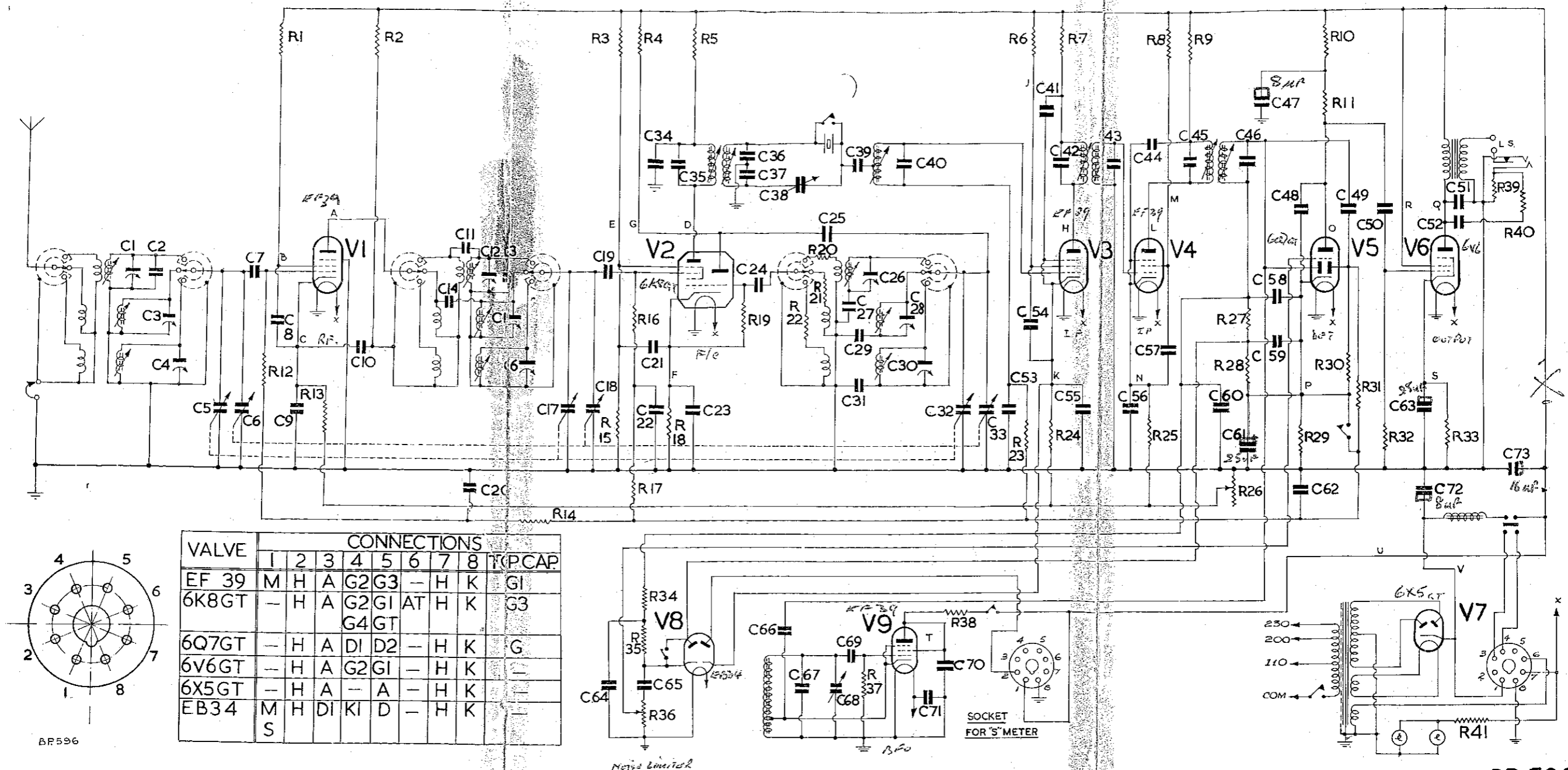

VALVE	CONNECTIONS								PCAP
	1	2	3	4	5	6	7	8	
EF 39	M	H	A	G2	G3	-	H	K	G1
6K8GT	-	H	A	G2	G1	A	H	K	G3
6Q7GT	-	H	A	D1	D2	-	H	K	G
6V6GT	-	H	A	G2	G1	-	H	K	-
6X5GT	-	H	A	-	A	-	H	K	-
EB34	M	H	D1	K1	D	-	H	K	-
	S								

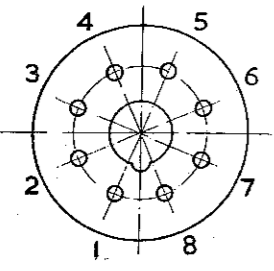

BP 596

FIG. 1.

BP 596  
7 4.12-46

# EDDYSTONE RECEIVERS

## INTRODUCTORY NOTES

**Manufacturers :** Messrs. Stratton and Co. Ltd., Eddystone Works, Alvechurch Road, West Heath, Birmingham 31.

The front panel and the coil-box of all models are stout diecastings, while separate chassis are used for the power unit, I.F. section and output stage.

In each model, the cabinet is easily removable by withdrawing four large screws at the rear. Most parts of the receiver are then readily accessible.

All coils (R.F. and I.F.) are permeability tuned, trimmers also being provided in the R.F. and oscillator sections. Alignment is carried out following the normal procedure, variations being indicated where necessary. When changing a valve, it is usually only necessary to re-adjust the appropriate trimmer capacitors to correct any differences in stray capacitance, and there is then no need to remove the lid of the coil-box. For full alignment, however, this lid must be taken off. Always remember to adjust the trimmers at the high-frequency end of a range and the cores at the low-frequency end. The correct alignment points are given in the table below. Where variable selectivity is fitted (Models 750, 680), alignment should be carried out with the control set at *maximum* selectivity.

Models 640, 740 and 750 are adapted for operation from a 6-volt accumulator and auxiliary H.T. supply. The octal plug which completes the L.T. connections must be inserted in the socket at the rear. This plug and its internal connections should be examined if any failure of or variation in the heater supply occurs.

During manufacture, all receivers are subjected to an ageing process and are then calibrated to an accuracy of plus or minus 0.5 per cent.

The transformers fitted to mains models are for 40-60 c/s. operation and are not suitable for 25 c/s. supplies.

The glass and dial can be cleaned by using a thin artist's brush, long enough



FIGURE 1. APPEARANCE OF THE MAIN EDDYSTONE RECEIVER (MODEL 740)

to reach all parts of the glass. The dial lights are standard in all receivers, bulbs with miniature bayonet caps, rated at 6.3 volts, 0.3 amp., being used. To change a lamp, it is only necessary to press the holder, which is sprung into place, and pull out.

A standard wiring code is used as follows :

A.C. mains . . . . .	Grey	Heaters . . . . .	Yellow
H.T. . . . .	Red	Negative to chassis . . . . .	Brown
Anodes . . . . .	Light blue	Chassis potential . . . . .	Black
Grids . . . . .	Green	Other leads . . . . .	White

ALIGNMENT FREQUENCIES

Model	Range 1		Range 2		Range 3		Range 4		Range 5	
	High (Mc/s)	Low (Mc/s)	High (Mc/s)	Low (Mc/s)	High (Mc/s)	Low (Mc/s)	High (kc/s)	Low (kc/s)	High (kc/s)	Low (kc/s)
556, 504	30	14	13	6.5	6.5	3	2800	1400	1300	600
659, 670	28	13	12	6	2.6	1.3	1200	600	—	—
640	30	13	12	5	4	2	—	—	—	—
710, 740	28	12	9	4	3.2	1.5	1200	550	—	—
750	30	13	11	4.7	4.2	2	1350	550	—	—
680	28	14	13	6	5.8	2.5	2500	1200	1100	500

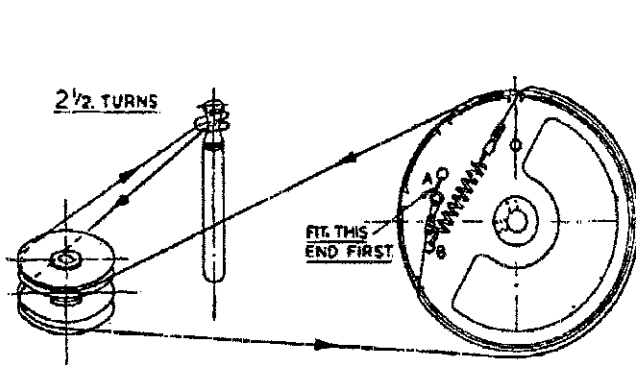

**BANDSET.**

TURN BANDSET CONDENSER TO MAXIMUM CAPACITY; THE DRIVE DRUM FITTED TO THE CONDENSER SPINDLE SHOULD THEN BE ORIENTATED AS SHOWN. USE CORD D.1069. COMMENCE AT 'A' & FINISH AT 'B'.

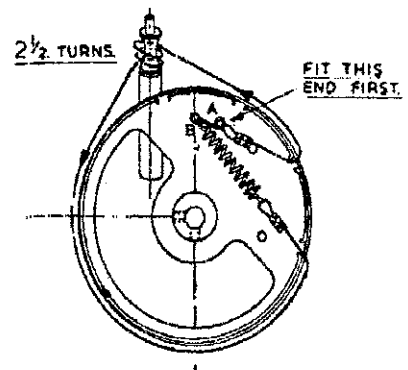

**BANDSPREAD.**

WITH THE BANDSPREAD CONDENSER SET AT MAX. CAPACITY, THE DRIVE DRUM IS FITTED IN THE POSITION SHOWN. USE CORD D.1070. COMMENCE AT 'A' & FINISH AT 'B'.

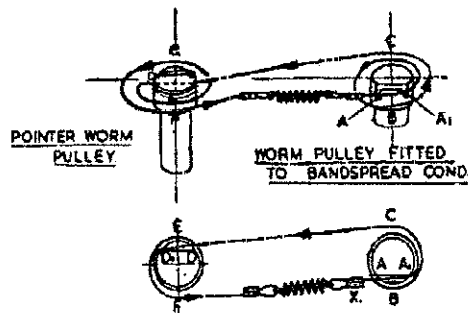

**BANDSPREAD POINTER DRIVE.**

SET BANDSPREAD CONDENSER AT MAX CAPACITY. WITH WORM PULLEYS IN POSITIONS SHOWN, FIT CORD D.1071. IN SLOT A.A. SO THAT THE CORD CLIP 'X' JUST CLEARS THE PULLEY. NOW COMPLETE ASSEMBLY BY FOLLOWING A-B-C-D-D.E-F.

CORD DRIVE REPLACEMENT--EDDYSTONE MODEL 640

Turn receiver panel downwards top towards you ; then with cover removed and looking down on the receiver, the cord drives would appear similar to the inverted rear views shown. To fit cords, remove dial bulbs and reflector plate and proceed as indicated in the diagrams.

CORE AND TRIMMER LAY-OUT—  
EDDYSTONE MODELS 504, 556

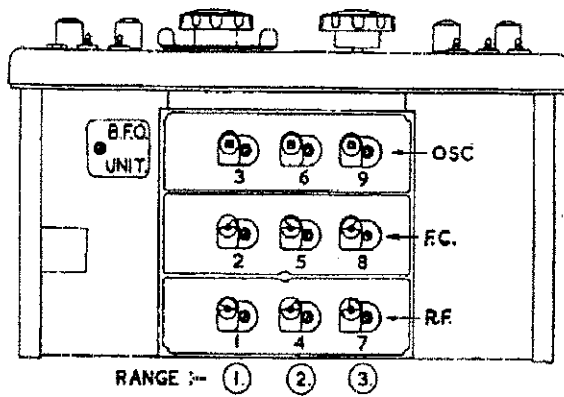
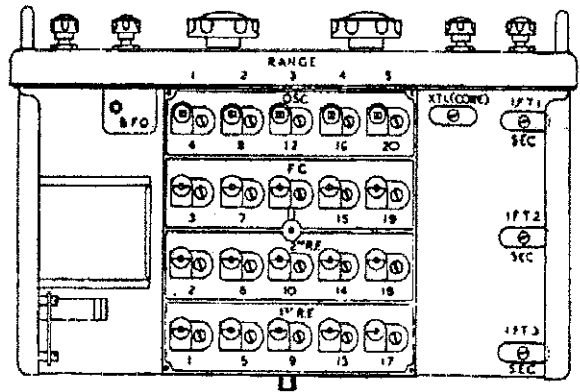

CORE AND TRIMMER LAY-OUT—  
EDDYSTONE MODEL 640

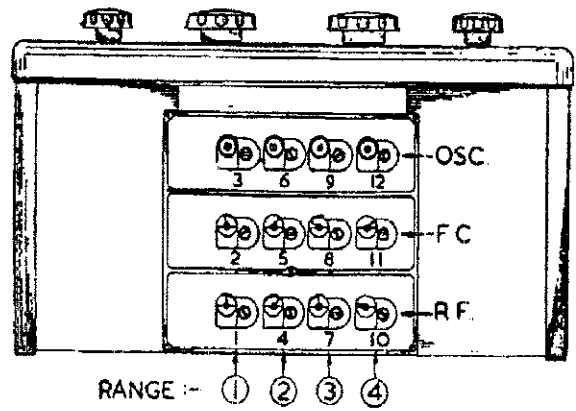

CORE AND TRIMMER LAY-OUT—  
EDDYSTONE MODELS 659, 670, 740, 710

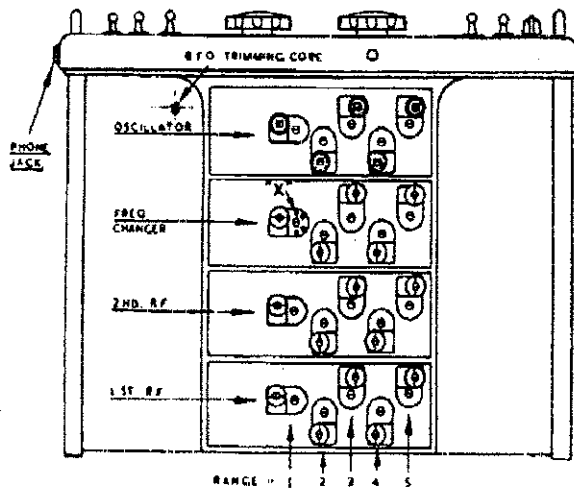

CORE AND TRIMMER LAY-OUT—  
EDDYSTONE MODEL 680

# EDDYSTONE

# Model 640

**General Description :** Nine-valve (including rectifier), three-waveband communications receiver with crystal filter and noise limiter. Released 1947.

**Power Supplies :** A.C. mains, 100-110 and 200-250 volts.

**Intermediate Frequency :** 1600 kc/s. nominal. All I.F. circuits should be peaked to the frequency of the crystal in the first I.F. stage.

**Valves :** (V1) EF39; (V2) ECH35 or 6K8G; (V3) EF39; (V4) EF39; (V5) 6Q7GT; (V6) 6V6GT (metal 6V6 must not be used); (V7) 6X5GT; (V8) EB34 (noise limiter); (V9) EF39 (B.F.O.).

**Notes :** Input impedance (aerial terminals) 400 ohms nominal. Output impedances 2.5 and 4000 ohms. The output across the headphones' socket is attenuated.

The R.F. Gain Control affects the amplification of the R.F. and I.F. valves. In later models, the Send/Receive switch reduces R.F. and I.F. gain, but does not disconnect the H.T. from the valves, a 22000-ohm resistor being wired across one pair of contacts. Non-delayed A.V.C.

Where I.F. break-through is experienced on all bands, the connections to the rotor and stator vanes of the phasing capacitor C38 should be reversed. Should I.F. break-through occur only on band 3, a 1600-kc/s. aerial filter should be fitted.

Excessive B.F.O. noise (rustle) may be due to a defective injection capacitor (C66).

Not shown in the circuit diagram is a 0.0005- $\mu$ F. mica capacitor wired across the heater of V2.

**Alignment Procedure :** Trimmer lay-out and alignment frequencies are given on pages 196-7.

**Voltage Values :** Voltages given below are between the points indicated and chassis. Receiver at 14 Mc/s. on Range 1, aerial shorted out; R.F. and A.F. gain controls maximum; crystal, noise limiter and B.F.O. off. The voltage indicated depends upon the internal resistance of the particular meter employed. A tolerance of plus or minus 5 per cent should be allowed on the figures given.

Circuit Reference	1000 ohms/volt Testmeter	333 ohms/volt Testmeter	Circuit Reference	1000 ohms/volt Testmeter	333 ohms/volt Testmeter
A	200 v.	190 v.	M	85 v.	70 v.
B	70 v.	60 v.	N	2.2 v.	2.1 v.
C	3.0 v.	2.75 v.	O	75 v.	40 v.
D	225 v.	200 v.	P	1.4 v.	0.8 v.
E	85 v.	85 v.	Q	217 v.	215 v.
F	4.1 v.	3.8 v.	R	225 v.	225 v.
G	75 v.	70 v.	S	10.5 v.	10 v.
H	200 v.	190 v.	T	95 v.	90 v.
J	75 v.	60 v.	U	225 v.	225 v.
K	3.0 v.	2.75 v.	V	250 v.	250 v.
L	200 v.	190 v.			

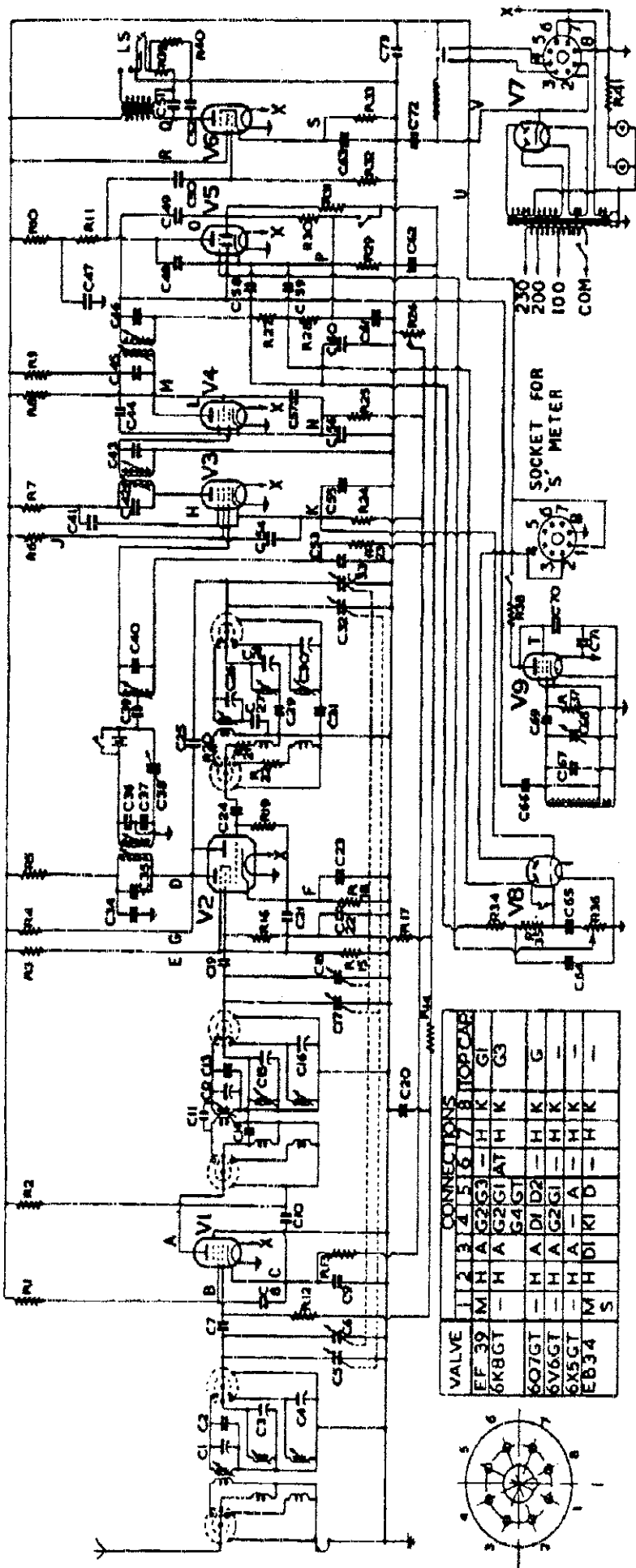

CIRCUIT DIAGRAM—EDDYSTONE MODEL 640

- Capacitors.**  
 3/20 pF. (air) C1, C16, C17, 400 pF.  
 5/20 pF. (ceramic) C2, C3, C4, C12, 0.01 (paper)  
 3 pF. C5, C17, C32 12-366.5 pF.  
 6 pF. C6, C18, C33 9-46.2 pF.  
 10 pF. C66  
 20 pF. C14  
 40 pF. C2, C20, C39  
 100 pF. C49, C58, C59  
 300 pF. C7, C19, C24  
 1700 pF. C35, C40, C42, 0.0005  
 950 pF. C29 0.002 (mica)  
 380 pF. C31 0.01 (mica)  
 Bandset capacitor (C5, C17, C32) 12-366.5 pF.  
 Bandspread capacitor (C6, C18, C33) 9-46.2 pF.  
 Crystal phasing capacitor C38  
 B.F.O. pitch capacitor C68
- Resistors.**  
 12 2.6 (wire) R41  
 100 R30  
 270 R21  
 330 R33  
 400 R18, R25  
 500 (or 500) R13, R24  
 3.3k R22  
 4.7k (or 5000) R4, R5, R7  
 15k R3  
 20k (or 25k) R15  
 22k R38  
 All 1/2-watt except R3, R4, R15, R33 (1-watt).  
 27k (or 30) R41  
 33k R40  
 47k R19, R23, R17  
 100k R1, R27  
 0.27M R11, R32  
 0.47M R12, R14, R16, R17, R28, R30, R31  
 1M R34  
 2.2M R26  
 10k pot. R25  
 0.5M pot. R36
- Arbitrary Scale**  
 (based on 6 db. change per S unit)  
 S1 7.5  $\mu$ A. S6 77  $\mu$ A.  
 S2 16  $\mu$ A. S7 100  $\mu$ A.  
 S3 27  $\mu$ A. S8 185.5  $\mu$ A.  
 S4 41  $\mu$ A. S9 157  $\mu$ A.  
 S5 58.5  $\mu$ A.
- SOCKET FOR 'S' METER**  
 230  
 200  
 100  
 COM
- CONNECTIONS**
- | VALVE | 1 | 2 | 3 | 4 | 5 | 6 | 7 | 8 | TOP | CAR |
|-------|---|---|---|---|---|---|---|---|-----|-----|
| EF 39 | M | H | A | G | G | - | H | K | G   |     |
| 6K8GT | - | H | A | G | G | A | H | K | G   |     |
| 6O7GT | - | H | A | D | D | - | H | K | G   |     |
| 6V6GT | - | H | A | G | G | - | H | K | -   |     |
| 6X5GT | - | H | A | - | - | A | - | H | K   |     |
| EB34  | M | H | D | K | D | - | H | K | -   |     |
- 'S' METER**  
 10000  
 1000  
 200  
 100