

INTERNATIONAL MARINE RADIO COMPANY LIMITED

CROYDON

HANDBOOK FOR MARINE ALL-WAVE COMMUNICATION

RECEIVER TYPE IMR. 54

---

IMR54/5406

Printed in England

International Marine Radio Company Limited reserve the right to make such changes in design of the equipment described in this handbook as are considered necessary due to progress in radio technique.

This handbook belongs to International Marine Radio Company Limited, and is issued on condition that it is not copied, reprinted or disclosed to a third party either wholly or in part without the consent in writing of International Marine Radio Company Limited.

C O N T E N T S

PART 1	GENERAL DESCRIPTION	.....	PAGE 1
PART 2	TECHNICAL DESCRIPTION	.....	PAGE 4
PART 3	OPERATING INSTRUCTIONS	.....	PAGE 6
PART 4	INSTALLATION INSTRUCTIONS	.....	PAGE 9
PART 5	COMPLETE ALIGNMENT AND FAULT CHECKING		PAGE 11
PART 6	COMPONENT LIST	.....	SHEETS 1-12 incl.

D R A W I N G S

FRONT VIEW	.....	IM. 1592
PLAN OF CHASSIS	.....	IM. 1594
UNDER CHASSIS VIEW	.....	IM. 1593
GENERAL SCHEMATIC	.....	IM. 1595
ASSEMBLY OF RECEIVER AERIAL CO-AXIAL CONNECTOR		SM. 1169
RECEIVER D.C. MAINS DROPPING RESISTOR.....		IM. 1600
RECEIVER AERIAL DISTRIBUTION UNIT	.....	IM. 1601
MAINS FILTER UNIT MR. 19948(IMR. 60)	.....	IM. 1814

## MARINE ALL-WAVE COMMUNICATION RECEIVER TYPE IMR. 54

---

This receiver complies with the General Post Office Specification entitled "Performance Specification for a General Purpose Receiver for Ships". It will therefore meet the requirements of the following:-

British Merchant Shipping (Wireless Telegraphy) Rules.

Rules laid down by the International Safety of Life at Sea Convention, 1948.

International Radio Regulations laid down by the Radiocommunications Convention, Atlantic City 1947.

The relevant sections of the equipment also conform to the requirements of Lloyds and I.E.E. Rules for electrical installations aboard ship.

### GENERAL

The IMR. 54 Receiver is a high class marine communication receiver covering the requirements of a long-wave, medium-wave and short-wave main receiver in all compulsorily equipped ships.

### FEATURES

Complete coverage of the frequency band 15 Kc/s to 31 Mc/s in 10 ranges.

Direct operation from 110 - 250 volts A.C. or D.C. without DC/AC conversion equipment.

Mechanical bandspread giving scale of 160 inches for each range.

16 inch scale calibrated in frequency.

Meter and switch for checking all valves. This meter also operates as a tuning indicator.

Four degrees of selectivity, including crystal filter in very narrow position.

Built-in loudspeaker for monitoring purposes.

Use of International and preferred type valves.

Compartment in cabinet for stowage of spare valves, fuses etc.

Ease of access for servicing combined with robustness.

Listening-through facilities are incorporated to enable "break-in" operation when used in conjunction with a local transmitter.

### BASIC CIRCUIT ARRANGEMENT

The circuit is superheterodyne throughout, with two intermediate frequencies. A total of 12 valves are used.

The power supply is basically 110 volts A.C. or D.C. in order that it may be operated directly from ship's mains without the use of rotary machines or other conversion equipment. In the case of D.C. voltages higher than 110V a special resistor unit is provided and for higher A.C. voltages a step-down transformer. Operation from a 24 volt emergency battery source may be obtained by means of an external vibrator or Rotary-Transformer Power Unit.

PERFORMANCE

Frequency Ranges:

Range 1	14 - 31 Mcs	( 9.7 - 21.5 metres)
Range 2	8 - 14 Mcs	( 21.5 - 37 metres)
Range 3	3.8 - 8 Mcs	( 37.5 - 79 metres)
Range 4	1.5 - 3.8 Mcs	( 79 - 200 metres)
Range 5	600 - 1500 Kc/s	( 200 - 500 metres)
Range 6	240 - 600 Kc/s	( 500 - 1250 metres)
Range 7	92 - 240 Kc/s	( 1250 - 3260 metres)
Range 8	48 - 92 Kc/s	( 3260 - 6250 metres)
Range 9	26 - 48 Kc/s	( 6250 - 11,539 metres)
Range 10	15 - 26 Kc/s	( 11539 - 20,000 metres)

Tuning is by means of a 2-speed gear drive giving reduction ratios of 125-1 and 25-1

Mechanical **bandsread** amounts to 160 inches of scale per range.

All ranges are calibrated in frequency. Scale length is 16 inches.

Selectivity

Four degrees of selectivity are provided as follows:-

BANDWIDTH	Wide	Inter - Mediate	Narrow	Very Narrow
FREQUENCY RANGE	1.5 - 25 Mcs	160 Kcs - 25 Mcs	15 Kcs - 25 Mcs	15 - 160 Kcs
Not more than 6 db discrimination at frequencies removed from tune by.....	4 Kcs	1.5 Kcs	0.5 Kcs (above 100 Kcs)	-
At least 30db discrimination for all frequencies removed from tune by.....	12 Kcs	6 Kcs	2.5 Kcs	0.75 Kcs
At least 60 db discrimination for all frequencies removed from tune by.....	24 Kcs	12 Kcs	5 Kcs	5 Kcs
At least 90 db discrimination at all frequencies removed from tune by.....	50 Kcs	35 Kcs	25 Kcs	25 Kcs

Image Discrimination

<u>Frequency Range</u>	15 - 1000 Kcs at least 80 db down
	1.0 - 1.5 Mcs at least 70 db down
	1.5 - 7 Mcs at least 60 db down
	7 - 15 Mcs at least 40 db down
	15 - 31 Mcs at least 25 db down

IMR54/5406

I.F.Rejection      110 Kcs I.F. at least 60 db down  
                          465 Kcs I.F. at least 90 db down

Signal-to-Noise/Sensitivity

For 50 milliwatts output

Frequency	Input	Signal/Noise Ratio	Wave	Bandwidth
15 - 160 Kc/s	4 - 20 uV	10 db	A1	Narrow
160 - 1500 Kc/s	6 - 10 uV	10 db	A1 & A2	Intermediate
1.5- 4.0 Mcs	1.5- 3 uV	10 db	A1 & A2	Wide
4.0- 10 Mcs	2 - 3 uV	10 db	A1 & A2	Wide
4.0- 10 Mcs	4 - 6 uV	20 db	A1 & A2	Wide
10- 31 Mcs	2 - 4 uV	10 db	A1 & A2	Wide
10- 31 Mcs	8 - 10 uV	25 db	A1 & A2	Wide

Maximum Output = 1.0 watts.

The above figures were taken under the following test conditions:

Dummy Aerial      Above 4 Mcs      =    75 ohms Resistances only.  
                          Below 4 Mcs      =    200 pf + 13 ohms.

A1      BFO Switched Off  
 A2      Carrier removed.

Fidelity

Response level within 4 db from 300 - 2,500 cps with wide band selectivity.

Automatic Volume Control

Audio output is constant within 8 db for increases up to 80 db above an input of 8 uV.

Build-up time constant is 0.1 second and decay time 1 second.

Aerial Input Impedance

72 ohms nominal.

Power Consumption

Approximately 82 watts at 110 volts A.C. or D.C.

GENERAL CONSTRUCTION

All Components and materials are of tropical finish to the latest Specification.

The cabinet is of louvred mild steel with non-ferrous chassis and cast coil box. All metal parts are protected against rust and corrosion and the cabinet is finished in grey stove enamel with chromium-plated handles and fittings.

Shock absorber mountings are provided where required.

Dimensions      Overall

Length      2ft - 5<sup>3</sup>/<sub>8</sub>" (74.7 cm)  
 Depth      1ft - 5<sup>3</sup>/<sub>4</sub>" (45.1 cm)  
 Height      1ft - 2 13/16 ins. (38.5 cm)  
 Weight      134 lbs (60.9 kg)

PART 2  
TECHNICAL DESCRIPTION

The IMR.54 Receiver is a superheterodyne and comprises the following valves and stages:-

V1. Variable- $\mu$ R.F.Pentode	-	1st Radio Frequency Amplifier
V2. Variable- $\mu$ R.F.Pentode	-	2nd Radio Frequency Amplifier
V3. Heptode	-	Frequency Changer
V4. R.F.Pentode	-	Local Oscillator
V5. R.F.Pentode	-	Beat Frequency (CW) Oscillator
V6. Variable- $\mu$ R.F.Pentode	-	1st I.F.Amplifier
V7. Variable- $\mu$ R.F.Pentode	-	2nd I.F.Amplifier
V8. Variable- $\mu$ R.F.Pentode	-	A.V.C.Amplifier
V9. Double-diode-triode	-	Det. A.V.C. and 1st A.F.Amplifier
V10. Output Beam tetrode	-	Power Output
V11. Double-diode	-	A.V.C. Detector and Metering
V12. Voltage Regulator		

Basically the receiver operates from 100 to 115 volts A.C. (40 - 60 cps) or D.C. without the use of external conversion equipment. When operated from higher voltages such as 200 - 250 volts an external dropping resistor unit is employed. In the case of 200-250 volts A.C. a "step-down" transformer may be used instead of the resistor unit as a more economic arrangement.

From the above table it will be seen that two radio frequency amplifier stages are incorporated. On bands 1, 2, 3, 4, 5 and 6 both are in circuit whilst on bands 7, 8, 9 and 10 only one is employed. These Amplifiers utilise two high slope variable- $\mu$  pentodes and the final radio frequency amplifier feeds into a pentagrid frequency changer. In order to produce the required intermediate frequency the output of a separate local oscillator circuit is injected into the frequency changer valve. The local oscillator has a stabilised H.F. supply and this, together with the use of temperature-compensated condensers results in a high degree of stability.

In order to cover the complete frequency range in a single receiver the intermediate frequency amplifier may be switched to operate at alternate frequencies, e.g. 110 Kcs and 465 Kcs. The latter change of intermediate frequency is performed automatically by means of the band selector switch. The intermediate frequencies are employed in the different bands as follows:-

Bands 1, 2, 3, 4, 5 and 7	-	465 Kcs.
Bands 6, 8, 9 and 10	-	110 Kcs.

The intermediate frequency amplifier provides four degrees of selectivity viz: Very Narrow, Narrow, Intermediate and Wide. In the "Very Narrow" condition a vacuum mounted crystal is employed. Other degrees of selectivity are determined by variations of coupling within the I.F. transformers, whilst substantially constant gain is maintained by switching the load of the signal diode of the detector which immediately follows the intermediate frequency amplifier. The detector employs a double-diode-triode valve, the triode portion of which operates as an audio frequency amplifier and is resistance-capacity coupled to the output pentode.

Automatic volume control is obtained by coupling the first I.F. amplifier stage to a separate A.V.C. amplifier valve and diode A.V.C. detector valve. The latter applies A.V.C. voltages to both radio frequency amplifier stages and both intermediate frequency amplifier stages.

The A.V.C. diode is part of a double diode valve V.11 in which the second diode is inserted across the A.F. circuit between the A.F. amplifier and output valves. This diode operates in conjunction with the "listening

through facilities. When the relay REL 1 is operated (transmitter key depressed) the aerial is earthed through one pair of changeover contacts and the secondary of the loud speaker transformer is open-circuited. The other pair of contacts simultaneously connect the diode anode to the anode supply of the output valve via R68, thus causing the diode to conduct and limit the A.F. to the output valve. A variable C/R network between the diode anode and the chassis "earth" provides "hangover" adjustment between 80 - 120 milliseconds.

C.W. reception is provided for by a separate beat frequency oscillator circuit injecting into the grid of the 2nd I.F. valve.

A noise limiter utilizing a metal rectifier RECT 1 is incorporated prior to the signal diode of V.9. This limiter may be switched in and out of circuit at will.

The circuit includes a built-in monitor loud speaker which is automatically disconnected when headphones are plugged into J.1. The second jack (J.1) provides a position for an external loudspeaker or another pair of headphones as required.



PART 3  
OPERATING INSTRUCTIONS

Controls

The controls provided on the front panel are:-

Mains ON/OFF Switch  
R.F. Gain Control  
A.F. Gain Control  
I.F. Gain Control  
B.F.O. ON/OFF Switch  
B.F.O. Pitch Control  
Frequency Range Selector Switch  
Main Tuning Control  
A.V.C. ON/OFF Switch  
N.L. ON/OFF Switch  
Selectivity Switch  
Valve Check Switch

The above controls function as follows:-

Mains ON/OFF Switch

This switch controls both poles of the supply input A.C. or D.C.

R.F. Gain Control

Provides a means for varying the bias on the two radio frequency amplifier valves V1 and V2 and thus the gain of these stages.

A.F. Gain Control

Controls the input to the audio frequency amplifier valve V9 and thus the audio frequency output of the receiver.

I.F. Gain Control

Provides a means for varying the bias on the two intermediate frequency amplifier valves V6 and V7 and thus the gain of these stages.

B.F.O. ON/OFF Switch

Completes or disconnects the H.T. supply to the beat-frequency (CW) oscillator valve, thus providing for C.W. or M.C.W./Telegraph reception.

B.F.O. Pitch Control

Alters the beat frequency oscillator tuning above and below zero beat, providing a means for setting the C.W. note to the required pitch.

Frequency Range Selector Switch

Changes the frequency range of the receiver as required. The ranges are signwritten on the front panel 1 to 10 in frequency (Kcs/Mcs).

Main Tuning Control

This control rotates R.F. Mixer and local oscillator tuning condensers and continuously alters the reception frequency.

A.V.C. ON/OFF Switch

Places the automatic volume control system in or out of circuit as required.

N.L. ON/OFF Switch

Places the Noise Limiter rectifier in or out of circuit as required.

Selectivity Switch

This switch provides four degrees of selectivity as follows:-

Wide  
Intermediate  
Narrow  
Very Narrow

The bandwidths provided by the various positions are tabled in part of this handbook.

### Valve Check Switch

This switch together with the meter (M1) provides a means for checking the anode currents of all valves. Typical readings should be as follows:-

<u>Valve</u>	<u>Scale Reading</u>	<u>Scale multiplier for actual currents (mA)</u>
V1	7	X2. = 14 mA
V1 Ranges 9 and 10 only	1	X2. = 2 mA
V2	7	X2. = 14 mA
V3	5.5	X2. = 11 mA
V4 Dependent on Range setting	3 to 4	X1. = 3-4 mA
V5 Ranges 1,2,3,4,5 and 7	2.5	X1. = 2.5 mA
V5 Ranges 6,8,9 and 10	3.5	X1. = 3.5 mA
V6	7	X2. = 14 mA
V7	7	X2. = 14 mA
V8	6	X2. = 12 mA
V9	.9	X2. = 1.8 mA
V10	8	X5. = 40 mA

### Headphones and Loudspeaker (external)

The jack J.1 provides a position for high impedance headphones and automatically disconnects the internal loudspeaker.

Jack J.2 makes provision for an external low-impedance loudspeaker or low impedance headphones. Use of the latter jack does not disconnect the internal loudspeaker.

### OPERATION (typical)

It is difficult to lay down definite routine instructions for the operation of a receiver of this type as the method of approach will vary with different personnel and, as familiarity grows, many "short-cuts" may be taken. However the following general method may be recommended:-

1. Switch ON Main Supply. It is preferable to do this about one minute or a minimum of 30 seconds before the receiver is required for use, as the series-connected heaters take somewhat longer to attain emission than when parallel connected.
2. Set Frequency Range Selector Switch to required frequency band. This can be done while heaters are attaining emission.
3. Set I.F. Gain Control at maximum, or near maximum.
4. Set R.F. Gain Control near, or at maximum.
5. Set A.F. Gain Control as high as inherent background noise permits. Generally half or three quarters of the way to maximum is normal for sufficient loading of internal loudspeaker when searching. If headphones are in use the A.F. gain should be set at a much lower setting.
6. Switch off A.V.C.
7. Switch off Noise Limiter unless there is an unpleasant background of impulse noise, such as static or local mains interference.
8. Set Selectivity Switch to "Intermediate" position except in the case of bands 8, 9 and 10 when it may be found easier to commence with the "Narrow" position.
9. Switch ON B.F.O. When searching for C.W., M.C.W., or telephony it is considered advantageous to use the B.F.O. injection in the first instance. Set B.F.O. Pitch to centre position.
10. Set the Tuning Control by the fast (inner) knob as near as possible to the published frequency of the required station.

11. Rotate the slow (outer) knob above and below the original rough setting until the station is heard.
12. Adjust R.F. I.F. and A.F. Gain Controls in that order until required signal strength is obtained.

Further Adjustments etc.

C.W. (A1) Telegraphy If the required signal is C.W. (A1) adjust B.F.O. Pitch Control for readable note, usually around 800 to 1000 cps suits most personnel. In order to obtain the required signal entirely free from adjacent channel interference set Selectivity Switch to "Narrow" or "Very Narrow". In the case of frequency ranges 8, 9, and 10 it will be found most advantageous to use the "Very Narrow" position. If there is a tendency to fading switch on A.V.C.

M.C.W. (A1) Telegraphy In the case of M.C.W. (A2) it is usual although not essential to switch off the B.F.O. Other adjustments are as for C.W. above except that the maximum selectivity usually employed would be with the Selectivity Switch in the "Narrow" position.

Telephony (A3) Proceed as for M.C.W. but switch off B.F.O. after telephony "carrier" wave has been heard and set Selectivity Switch to "Wide" position for maximum fidelity.

LOGGING

From the front view of the receiver it will be noted that in addition to the Main Scale calibrated in frequency, there is a second 16" scale marked in hundreds 0 - 1000. Also at the top centre of the Tuning Scale there is a third scale of circular form engraved 0 - 100. These two scales are known as the "Rough" and "Fine" Logging Scales. Their purpose is to provide a ready means for recording settings of stations frequently used. The "Fine" scale acts as a vernier to the "Rough" scale and stations may be recorded as follows:-

<u>STATION</u>	<u>PUBLISHED FREQUENCY</u>	<u>FREQUENCY RANGE</u>	<u>LOGGING SCALES</u>
<u>EXAMPLE</u> (not to be taken as exact for all receivers)			
Portishead Radio GKS	16845 Kc/s	1	290

In the above the figure of 290 represents a setting between 200 - 300 on the "Rough" scale and 90 on the "Fine" scale.

Setting of Muting Delay (Listening-through System)

Lifting the lid of the receiver will reveal a knob engraved 80 - 120 milliseconds. This control sets the operational delay of the muting diode (part of V11) and is normally adjusted during installation to the local conditions. This adjustment will vary with the amount of "pick-up" from the transmitter but for efficient listening-through the least possible delay should be used.

PART 4  
INSTALLATION INSTRUCTIONS

GENERAL

The receiver is usually shipped ready for operation with all valves, lamps and fuses in place, therefore little preparation is necessary except to ascertain that all valves are firmly seated in their holders and that screening "cans" are locked. Check also that the spares compartment in the lid contains all items listed on the "Spares Chart" inside the cover.

PROCEDURE

Having determined the most suitable position for the receiver in the Radio Office, remove the chassis by releasing the fixing screws located at each side of the cabinet. These screws are "captive" in the chassis lugs and should not be completely removed from the latter. The chassis can now be withdrawn.

Place the cabinet in the position selected for permanent fitting. Mark the fixing centres by running a pencil or other marking device through the holes in each of the four shock absorbers. Drill the bench or table at these four points in a manner suitable for the type of fixing to be used, e.g. bolts nutted at the lower end or relatively heavy coach screws.

After fixing re-insert chassis and fasten securely by means of the two side screws. Feed main supply lead through the appropriate bush at the rear of the cabinet. Insert the "cabinet earth" plug in the appropriate socket at centre-rear of chassis (refer IM.1594). Normally each receiver is supplied with a 4ft length of 72 ohm co-axial feeder terminated at one end in a co-axial plug suitable for the co-axial socket in the chassis. This length of co-axial feeder should now be fed through the cabinet bush immediately behind the chassis socket and the plug screwed home. At this juncture check that the insulation of the chassis has been maintained, i.e., that no circuit exists between either the inner conductor (aerial lead) or outer sheath of the co-axial feeder and the chassis. The outer sheath must be earthed ONLY to the cabinet or the "true" earth. THE CHASSIS MUST ALWAYS BE ISOLATED FROM TRUE EARTH.

Feed the two appropriate leads from the transmitter keying circuit through the remaining cabinet bush. These leads should be fitted in the 2-pin plug provided at the receiver. Insert the plug in the socket adjacent to the chassis earth socket (refer IM.1594) polarity being unimportant.

MAIN SUPPLY

If the mains supply is 110 - 115V D.C. the main lead from the receiver should be connected directly to the D.C. source. The polarity must be respected and the "Red" lead connected to positive line.

In the case of 220V D.C. a resistor voltage dropping unit MR.66717 must be connected in series with the positive line to receiver. For other voltages above 115V special voltage dropping units are necessary.

110-115V A.C. 60 cps mains may be connected directly to the receiver main supply lead. For voltages above 115 volts A.C. it is usual to employ a step-down transformer unit but the MR66717 Resistor Unit may be used for 220V A.C. if power consumption is not of importance.

AERIAL CONNECTION

The free end of the 4ft co-axial lead should be terminated as laid down in the system drawings for the vessel. Where an aerial distribution unit (MR.53285) is provided the aerial lead will be terminated at that unit in the normal manner. The outer braiding of the lead should be connected to ~~the~~ "true" earth at a convenient point.

EARTH CONNECTION

The terminal at the rear top centre of the receiver cabinet should be connected to the metal structure of the ship.

SETTING THE MUTING SYSTEM

This should be carried out when the whole station has been installed and the main transmitters are operating on full power. The object to be achieved is the most rapid receiver "recovery" when tuned exactly to the transmitter frequency.

PART 5  
COMPLETE ALIGNMENT AND FAULT CHECKING

PROCEDURE (refer IM.1593)

The receiver is permanently aligned before despatch from the factory and should require only normal maintenance in service, e.g. change of valves, lamps etc., but in case it is necessary to re-align at any time the following is the complete procedure. However, it must be remembered that such alignment can be carried out only where test gear is available as follows :-

Signal Generator(s) 15 Kcs to 32 Mcs 30% modulation at 400 cycles  
Power Output meter  
Crystal Frequency Standard  
Frequency Modulated oscillator covering 465 and 110 Kcs.  
Oscilloscope

I.F.ALIGNMENT - 465 Kcs Channel

Switch wave switch to Band 5  
A.V.C., B.F.O., and N.L. off  
I.F. Gain Maximum  
R.F. Gain Minimum

Connect frequency modulated oscillator to 3rd section of gang nearest to front panel and short circuit front section of this gang (this will stop oscillation).

Connect oscilloscope across diode load (i.e. from junction of R60 and R94 to earth).

Set selectivity switch to "Very Narrow" and align all 465 Kcs. dust cores in this position then switch to "Narrow" and align the crystal input and output coils for maximum, switch back to "Very Narrow" and adjust phasing condenser for a symmetrical curve then return again to "Narrow" and align the crystal input coil.

Disconnect F.M.O. and Oscilloscope.

Connect signal generator with direct output lead to 3rd section of gang nearest to front panel and insert a sensitive microammeter in the diode load at the point where R97 joins the cathode of V9, also connect the power output meter, - a convenient point is the external L.S. jack.

Now feed in a 465 Kcs. signal unmodulated  
Switch in "Very Narrow" 45 uV approximately for 4 uA in diode load  
Switch in "Narrow" 30 uV approximately for 4 uA in diode load, or  
13 uV for 50 mW with 30% modulation  
Switch in "Intermediate" 4 uV approximately for 4 uA in diode load,  
or 3 uV for 50 mW with 30% modulation  
Switch in "Wide" 6 uV approximately for 4 uA in diode load, or 15 uV  
approximately for 50 mW with 30% modulation.

NOTE: In the "Wide" check I.F. gain control should be reduced to step 10.

110 Kcs. Channel

Range switch to Band 6  
A.V.C., B.F.O., and N.L. off  
I.F. Gain maximum  
R.F. Gain minimum

Connect F.M.O. to 3rd section of gang nearest to front panel and short circuit front sections of this gang (this will stop oscillation).

Connect oscilloscope across diode load (i.e. from junction of R60 and R94 to earth).

Set selectivity switch to "Very Narrow" and align all 110 Kcs cores in this position, then switch to "Narrow" and align crystal input coil. Switch to "Very Narrow" and adjust crystal phasing condenser for symmetrical response.

Disconnect F.M.O. and oscilloscope.

Connect signal with direct output lead to 3rd section of gang nearest to front panel and insert a sensitive microammeter in the diode load at the point where R97 joins the cathode of V9. Also connect the power output meter - a convenient point is external L.S. socket.

Now feed in a 110 Kcs signal unmodulated.

Switch in "Very Narrow" 36 uV approximately for 4 uA diode current

Switch in "Narrow" 18 uV approximately for 4 uA diode current,  
or 9 uV approximately for 50 mW output 30% modulation.

Switch in "Intermediate" 12 uV approximately for 4 uA diode current,  
or 25 uV approximately for 50 mW output 30% modulation.

NOTE: Intermediate sensitivity taken with I.F. gain at step 9.

#### B.F.O. Alignment - 465 Kcs

Switch to Range 5.

A.V.C. on

Selectivity "Very Narrow"

B.F.O. pitch control, White spot at 12 o'clock.

Valve check meter switch to V6.

Feed in 465 Kcs signal about 100 uV and tune for minimum on valve check meter - then switch on B.F.O. and tune 465 Kcs B.F.O. core for zero beat.

110 Kcs - same procedure except Range switch to position 6.

#### A.V.C. Alignment - 465 Kcs

Switch to Range 5.

A.V.C. on

Selectivity "Very Narrow"

Valve check meter to V6.

Feed in heavy signal - say 1 mV and adjust 465 Kcs A.V.C. core for minimum reading on V6 - two positions will be found - the one further into the former is the correct one.

110 Kcs - same procedure except Range switch to position 6.

#### I.F. Sensitivity Stage-to-Stage

(Valves are indicated as guide only)

#### 465 Kcs

##### 1st I.F. Grid

Very Narrow } 84 uV for 50 mW 30% modulation  
Narrow } or 200 uV for 4 uA in diode load.

Inter- } 45 uV for 50 mW 30% modulation  
mediate } or 45 uV for 4 uA in diode load.

Wide } 38 uV for 50 mW 30% modulation  
or 70 uV for 4 uA in diode load.

##### 2nd I.F. Grid

Very Narrow } 15 uV for 50 mW 30% modulation  
Narrow } or 45 mV for 4 uA in diode load.

Inter- } 12 uV for 50 mW 30% modulation  
mediate } or 12 uV for 4 uA in diode load.

Wide } 8 uV for 50 mW 30% modulation  
or 17 uV for 4 uA in diode load.

<u>110 Kcs</u>	<u>1st I.F. Grid</u>	
	Very Narrow	} 120 uV for 50 mW 30% modulation 300 uV for 4 uA in diode load.
	Narrow	
	Inter- mediate	} 50 uV for 50 mW 30% modulation 25 uV for 4 uA in diode load
	<u>2nd I.F. Grid</u>	
	Very Narrow	} 9.5 uV for 50 mW 30% modulation or 25 uV for 4 uA in diode load.
	Narrow	
	Inter- mediate	} 17 uV for 50 mW 30% modulation or 8 uV for 4 uA in diode load

R.F. ALIGNMENT

The controls should be set as follows:-

Selectivity "Narrow"  
 B.F.O. off  
 A.V.C. off  
 N.L. off.  
 R.F. - reduce from maximum as required.  
 I.F. maximum.

Should it be found necessary to correct calibration errors a crystal frequency standard should be used and applied to the aerial terminal. Adjustment is then made to cores and trimmers appropriate to each range - this applies to all ranges but on ranges 7, 8, 9 and 10 a further variable is used - the series tracking condenser.

Ranges 1 to 6, adjust trimmers at H.F., cores at L.F.

Ranges 7 to 10, adjust trimmers at H.F., cores at middle of range and series tracking condenser at L.F.

Having completed the above adjustments to the oscillator coils, adjustments to the R.F. coils can now be carried out.

An output meter should be plugged into the external L.S. socket and the microammeter inserted in the diode load at the point where R97 joins the cathode of V9 - the micrometer is required on the L.F. Ranges when the generator is unmodulated.

The ranges are aligned at the following points:-

<u>Band</u>	<u>Trimmers</u>	<u>Cores</u>	<u>Load</u>
1	28 Mcs	14.5 Mcs	Resistive
2	14.5 Mcs	8 Mcs	Resistive
3	7.5 Mcs	4 Mcs	Resistive
4	3.4 Mcs	1.6 Mcs	Capacitive
5	1350 Kcs	600 Kcs	Capacitive
6	550 Kcs	250 Kcs	Capacitive
7	230 Kcs	95 Kcs	Capacitive
8	90 Kcs	50 Kcs	Capacitive
9	50 Kcs	27 Kcs	Capacitive
10	27 Kcs	No core adjustment - coils are inductance matched.	

When aligning range 7 it is convenient to feed in 465 Kcs and tune the core in the filter for minimum output. Also when aligning Range 8 feed in 110 Kcs and adjust trimmer on filter for minimum output.

A table of typical sensitivity figures for a 10db signal/noise ratio and 50 mW output is given below - Generator modulated 30% at 400 cycles.



<u>Range 1</u>	30 Mcs	A2	3 uV
	15 Mcs	A2	1 uV
<u>Range 2</u>	15 Mcs	A2	1.5 uV
	8 Mcs	A2	1.5 uV
<u>Range 3</u>	7.5 Mcs	A2	1.5 uV
	4 Mcs	A2	1.5 uV
<u>Range 4</u>	3.7 Mcs	A2	2 uV
	1.6 Mcs	A2	1.5 uV
<u>Range 5</u>	1.4 Mcs	A2	3 uV
	600 Kcs	A2	2.5 uV
<u>Range 6</u>	550 Kcs	A2	3 uV
	250 Kcs	A2	3 uV
<u>Range 7</u>	240 Kcs	A2	2.5 uV
	94 Kcs	A2	3 uV
<u>Range 8</u>	92 Kcs	A1	2 uV
	50 Kcs	A1	2 uV
<u>Range 9</u>	50 Kcs	A1	2.5 uV
	27 Kcs	A1	3 uV
<u>Range 10</u>	27 Kcs	A1	3 uV
	16 Kcs	A1	4 uV

#### FAULT CHECKING

As stated at the commencement of this section the receiver should require only normal maintenance during service such as valve or lamp replacement. Failure of any valve will break the series "valve chain" and all valves will remain unlit until the faulty valve is replaced. The lamp "chain" behaves in an identical manner.

Low H.T. supply due to a fault in the rectifier or smoothing system will be indicated by failure of the voltage regulator valve V12 to "strike". V.12 strikes around 90V.

As a guide towards the location of any more obscure fault which may occur the following voltage table will be of assistance:-

#### VALVE VOLTAGES - 110V INPUT

	<u>Avometer</u>		<u>Voltmeter</u> 20,000 ohms/volts		
	<u>A.C.</u>	<u>D.C.</u>	<u>A.C.</u>	<u>D.C.</u>	
V1. Anode to Chassis	94V	80V	98V	82V	
Screen to Chassis	98V	84V	101V	86V	<u>1st R.F.</u>
Cathode to Chassis	.9V	.7V	1V	.75V	
V2. Anode to Chassis	94V	80V	98V	82V	
Screen to Chassis	100V	87V	104V	87V	<u>2nd R.F.</u>
Cathode to Chassis	1V	.85V	1.1V	.9V	
V3. Anode to Chassis	99V	84V	104V	86V	
Screen to Chassis	76V	63V	82V	6.9V	<u>Mixer</u>
Cathode to Chassis	1.1V	.9V	1.2V	1.2V	
V4. Anode to chassis	72V	70V	75V	75V	<u>O.S.C.</u>
V5. Anode to Chassis	72V	70V	75V	75V	<u>B.F.O.</u>
V6. Anode to Chassis	95V	80V	98V	82V	
Screen to Chassis	98V	83V	102V	85V	<u>1st I.F.</u>
Cathode to Chassis	.95V	.75V	1V	.8V	

	Avometer		Voltmeter		
	A.C.	D.C.	20,000 ohms/ volts		
			A.C.	D.C.	
V7. Anode to Chassis	95V	80V	98V	82V	
Screen to Chassis	98V	82.5V	101V	84V	<u>2nd I.F.</u>
Cathode to Chassis	.95V	.75V	1V	.8V	
V8. Anode to Chassis	97V	82V	100V	84V	
Screen to Chassis	99V	83.5V	103V	85.5V	<u>A.V.C.Amp</u>
Cathode to Chassis	1.45V	1.1V	1V	1.15V	
V9. Anode to Chassis	5V	4.0V	5.3V	4.3V	<u>L.F.Amp</u>
Cathode to Chassis	.5V	.4V	1.2V	.95V	
V10. Anode to Chassis	97V	82V	98V	82V	
Screen to Chassis	103V	87V	104V	87V	<u>Output</u>
Cathode to Chassis	7V	5.05V	7.1V	5.25V	
V11. Cathode (AVC Section)	.9V	.7V	1V	0.8V	<u>Muting &amp;</u>
Cathode (muting section)	30V	24.5V	81V	67V	<u>AVC Valve</u>
(120 M/Sec Relay closed)					
V12 Anode	78V	77.5V	78V	78V	<u>Stabiliser</u>

#### MISCELLANEOUS NOTES

- a) All grub screws and locking devices are of the type requiring an Allen key for adjustment. An Allen key is provided in the spares compartment.
- b) A valve extractor should be used for removing valves. An extractor is supplied in the spares compartment.
- c) Fitting new Pointer Drive Wire

##### 1. Fitting

Length of cable required is 59 inches  
Place chassis in normal operating position.

Loosen the two corner pulleys which are fitted to the dial brackets and take off the two threaded cable drive pulleys (these are similar). With pliers, put a small right-angled bend on the starting end of the cable. Place this end of the cable through the slot of one of the drive pulleys and solder it on to the end of the pin. Slide this pulley on to the left hand drive spindle and wind up clockwise for about two or three turns, starting the cable through the pulley slot into the rear thread (i.e. at the grub screw end). Tighten the pulley on to the spindle. Stretch cable out up to the left hand corner pulley and with the free hand, remove together, the pulley and pivot screw; fit the cable into the pulley groove and replace the pulley which may be properly secured later. Still keeping the cable taut, stretch it across to the right hand corner pulley which is removed and refitted as in the case of the left hand pulley. Now stretch the cable towards the left and anchor it to the right hand corner of the rear drive plate in a taut condition with a suitable clamp, such as an ordinary paper fastener. Continue to stretch the cable to the left and again with pliers, put a small bend on the end of the cable. Fit this end into the second drive pulley and solder on to the pin as before. Hold the pulley with the slot and the cable on the top and the grub screw at the rear, and with the cable started in the front thread, wind the pulley anti-clockwise so as to approach the second (right hand) drive spindle, to which this pulley is then fitted, lightly tightening the grub screw. Now tighten the two pivot screws holding the corner pulleys.

2. Adjusting

Turn the tuning control in one direction to the limit of travel and note the position of the anchor pin on the drive pulley which holds the least amount of cable (this will be the left hand pulley if the control is turned anti-clockwise). Then the pin should be about  $\frac{3}{8}$ " from top vertical or say  $20^\circ$  towards the other drive pulley. Now turn the tuning control to the limit of travel in the other direction, when it should be seen that the anchor pin on the other drive pulley is in a corresponding position, i.e. towards the first drive pulley. If the positions of the pins do not correspond, then loosen the grub screws and turn the pulleys simultaneously in the same direction, such that the anchor pin positions are equalised, finally tightening the pulley grub screws.

Engage the jockey pulley to tension the cable.

The pointer carrier may now be moved along the slide rods to the correct position (preferably with the drive adjusted to one end of travel) and the cable spot soldered on to it.

COMPONENT LIST

REF.	DESCRIPTION	MR NO.
	<u>CONDENSERS</u>	
G1	.05 mfd $\pm$ 20% Tubular paper 500 volts TMC S34533	62807
G2	.1 mfd $\pm$ 20% Tubular paper 350 volts TMC S110138	62808
G3	50pf $\pm$ 10% Silvered mica 350 volts Lemco 1510	62809
G4	4-33 pf Air trimmer Stratton 4126P	62579
G5	60 pf $\pm$ 10% Silvered mica 350 volts Lemco 1510	62810
G6	4-33 pf Air Trimmer Stratton 4126P	62579
G7	40pf $\pm$ 10% Silvered mica 350 volts Lemco 1510	62811
G8	4-33 pf Air Trimmer Stratton 4126P	62579
G9	4-33 pf Air Trimmer Stratton 4126P	62579
G10	4-33 pf Air Trimmer Stratton 4126P	62579
G11	4-33 pf Air Trimmer Stratton 4126P	62579
G12	4-33 pf Air Trimmer Stratton 4126P	62579
G13	.01 mfd $\pm$ 20% Tubular paper 150 volts Dubilier 400	62812
G14	400 pf $\pm$ 2% Silvered mica 350 volts Lemco 1510	62813
G15	4-33 pf Air Trimmer Stratton 4126P	62579
G16	60 pf $\pm$ 10% Silvered mica 350 volts Lemco 1510	62810
G17	4-33 pf Air Trimmer Stratton 4126P	62579
G18	4-33 pf Air Trimmer Stratton 4126P	62579
G19	2000 pf $\pm$ 1% Silvered mica 350 volts Lemco 2515	62814
G20	80 pf $\pm$ 10% Silvered mica 350 volts Lemco 1510	62815
G21	4-33 pf Air Trimmer Stratton 4126P	62579
G22	2,000 pf $\pm$ 1% Silvered mica 350 volts Lemco 2515	62814
G23	.5 mfd $\pm$ 20% Tubular paper 200 volts TMC S120012	62816
G24	.5 mfd $\pm$ 20% Tubular paper 200 volts TMC S120012	62816
G25	150 pf Gang 1st R.F. Section, Stratton 4105PA	62580P
G26	365 pf Gang 1st R.F. Section, Stratton 4105PA	62580P
G27	.01 mfd $\pm$ 20% Tubular paper 150 volts Dubilier 400	62812
G28	.5 mfd $\pm$ 20% Tubular paper 200 volts TMC S120012	62816
G29	50pf $\pm$ 10% Silvered mica 350 volts Lemco 1510	62809
G30	4-33 pf Air Trimmer Stratton 4126P	62579

COMPONENT LIST FOR IMR54/5406

SHEET NO. 1

REF.	DESCRIPTION	MR NO
C31	60 pf $\pm$ 10% Silvered mica 350 volts Lemco 1510	62410
C32	4-33 pf Air Trimmer, Stratton 4126P	62579
C33	40 pf $\pm$ 10% Silvered mica 350 volts Lemco 1510	62811
C34	4-33 pf Air Trimmer, Stratton 4126P	62579
C35	6 pf $\pm$ 20% Silvered mica 350 volts Lemco 1510	62817
C36	6 pf $\pm$ 20% Silvered mica 350 volts LEMCO 1510	62817
C37	4-33 pf Air Trimmer, Stratton 4126P	62579
C38	4-33 pf Air Trimmer, Stratton 4126P	62579
C39	4-33 pf Air Trimmer, Stratton 4126P	62579
C40	.5 mfd $\pm$ 20% Tubular paper 200 volts TMC S120012	62816
C41	150 pf Gang 2nd R.F. Section Stratton 4105PA	62580P
C42	365 pf Gang 2nd R.F. Section Stratton 4105PA	62580P
C43	.5mfd $\pm$ 20% Tubular paper 200 volts TMC S120012	62816
C44	.5mfd $\pm$ 20% Tubular paper 200 volts TMC S120012	62816
C45	.5 mfd $\pm$ 20% Tubular paper 200 volts TMC S120012	62816
C46	800 pf $\pm$ 10% Silvered mica 350 volts Lemco 1510	62819
C47	800 pf $\pm$ 10% Silvered mica 350 volts Lemco 1510	62819
C48	2000 pf $\pm$ 1% Silvered mica 350 volts Lemco 2515	62814
C49	2,000 pf $\pm$ 1% Silvered mica 350 volts Lemco 2515	62814
C50	20 pf $\pm$ 10% Silvered mica 350 volts Lemco 1510	62818
C51	4-33 pf Air Trimmer, Stratton 4126P	62579
C52	60 pf $\pm$ 10% Silvered mica 350 volts Lemco 1510	62810
C53	4-33 pf Air Trimmer, Stratton 4126P	62579
C54	20 pf $\pm$ 10% Tubular ceramic 350 volts Erie N750	62818
C55	4-33 pf Air Trimmer, Stratton 4126P	62579
C56	4-33 pf Air Trimmer, Stratton 4126P	62579
C57	4-33 pf Air Trimmer, Stratton 4126P	62579
C58	4-33 pf Air Trimmer, Stratton 4126P	62579
C59	40 pf $\pm$ 10% Silvered mica 350volts Lemco 1510	62811
C60	4-33 pf Air Trimmer, Stratton 4126P	62579
C61	60 pf $\pm$ 10% Silvered mica 350 volts Lemco 1510	62810
C62	4-33 pf Air Trimmer, Stratton 4126P	62579

COMPONENT LIST FOR IIR54/5406

SHEET No. 2

REF.	DESCRIPTION	MR NO
C63	50 pf $\pm$ 10% Silvered mica 350 volts Lemco 1510	62809
C64	4-33 pf Air Trimmer Stratton 4126P	62579
C65	150 pf Gang mixer section, Stratton 4105/1PA	62580P
C66	365 pf Gang mixer section, Stratton 4105/1PA	62580P
C67	.5 mfd $\pm$ 20% Tubular paper 200 volts TMC S120012	62816
C68	.5 mfd $\pm$ 20% Tubular paper 200 volts TMC S120012	62816
C69	400 pf $\pm$ 2% Silvered mica 350 volts Lemco 1510	62813
C70	400 pf $\pm$ 2% Silvered mica 350 volts Lemco 1510	62813
C71	100 pf $\pm$ 10% Tubular ceramic 350 volts Erie N750	62426
C72	150 pf Gang Osc. Section Stratton 4105/1PA	62580P
C73	365 pf Gang Osc. Section, Stratton 4105/1PA	62580P
C74	4-33 pf Air Trimmer Stratton 4126P	62579
C75	4-33 pf Air Trimmer Stratton 4126P	62579
C76	5,500 pf $\pm$ 1% Silvered mica 350 volts Lemco 2515	62821
C77	5,200 pf $\pm$ 1% Silvered mica 350 volts Lemco 2515	62822
C78	4-33 pf Air Trimmer, Stratton 4126P	62579
C79	2,625 pf $\pm$ 1% Silvered mica 350 volts Lemco 2151	62823
C80	4-33 pf Air Trimmer, Stratton 4126P	62579
C81	1,485 pf $\pm$ 1% Silvered mica 350 volts Lemco 2515	62824
C82	4-33 pf Air Trimmer, Stratton 4126P	62579
C83	740 pf $\pm$ 1% Silvered mica 350 volts Lemco 2151	62825
C84	4-33 pf Air Trimmer Stratton 4126P	62579
C85	1,240 pf $\pm$ 1% Silvered mica 350 volts Lemco 2515	62826
C86	4-33 pf Air Trimmer Stratton 4126P	62579
C87	20 pf $\pm$ 10% Tubular ceramic 350 volts Erie N750	62827
C88	110 pf $\pm$ 10% Silvered mica 350 volts Lemco 1510	62828
C89	4-33 pf Air Trimmer Stratton 4126P	62579
C90	4-33 pf Air Trimmer Stratton 4126P	62579
C91	60 pf $\pm$ 10% Tubular ceramic 350 volts Erie N750	62829
C92	260 pf $\pm$ 2% Silvered mica 350 volts Lemco 1510	62830
C93	4-33 pf Air Trimmer, Stratton 4126P	62579
C94		

COMPONENT LIST FOR IMR54/5406

SHEET No. 3

REF.	DESCRIPTION	MR NO
C95	4-33 pf Air trimmer, Stratton 4126P	62579
C96	100 pf $\pm$ 10% Silvered mica 350 volts Lemco 1510	62840
C97	4-33 pf Air trimmer, Stratton 4126P	62579
C98	20 pf $\pm$ 10% Tubular Ceramic 350 volts Erie N750	62827
C99	4-33 pf Air trimmer, Stratton 4126P	62579
C100	60 pf Silvered mica $\pm$ 10% 350 volts Lemco 1510	62810
C101	4-33 pf Air Trimmer, Stratton 4126P	62579
C102	.5 mfd $\pm$ 20% Tubular paper 200 volts TMC S120012	62816
C103	800 pf $\pm$ 2% Silvered mica 350 volts Lemco 1510	62819
C104	800 pf $\pm$ 2% Silvered Mica 350 volts Lemco 1510	62819
C105	3-23 pf Air Trimmer, Stratton 3909PA	62581
C106	3-23 pf Air Trimmer, Stratton 3909PA	62581
C107	800 pf $\pm$ 2% Silvered Mica 350 volts Lemco 1510	62819
C108	800 pf $\pm$ 2% Silvered Mica 350 volts Lemco 1510	62819
C109	10 pf $\pm$ 20% Tubular ceramic 350 volts Erie N750	62831
C110	400 pf $\pm$ 2% Silvered Mica 350 volts Lemco 1510	62813
C111	400 pf $\pm$ 2% Silvered Mica 350 volts Lemco 1510	62813
C112	400 pf $\pm$ 2% Silvered Mica 350 volts Lemco 1510	62813
C113	400 pf $\pm$ 2% Silvered Mica 350 volts Lemco 1510	62813
C114	20 pf $\pm$ 10% Silvered Mica 350 volts Lemco 1510	62818
C115	3 pf $\frac{1}{2}$ pf Silvered mica 350 volts Lemco 1510	62832
C116	.5 mfd $\pm$ 20% Tubular paper 200 volts TMC S120012	62816
C117	.5 mfd $\pm$ 20% Tubular paper 200 volts TMC S120012	62816
C118	.5 mfd $\pm$ 20% Tubular paper 200 volts TMC S120012	62816
C119	200 pf $\pm$ 2% Silvered mica 350 volts Lemco 1510	62833
C120	.002 mfd $\pm$ 20% Tubular paper 350 volts Dubilier Metal Minicap	62834
C121	.002 mfd $\pm$ 20% Tubular paper 350 volts Dubilier Metal Minicap	62834
C122	.5 mfd $\pm$ 20% Tubular paper 200 volts TMC S120012	62816
C123	.5 mfd $\pm$ 20% Tubular paper 200 volts TMC S120012	62816
C124	20 pf $\pm$ 10% Silvered Mica 350 volts Lemco 1510	62818
C125	.5 mfd $\pm$ 20% Tubular paper 200 volts TMC S120012	62816

REF.	DESCRIPTION	MT. NO.
C126	400 pf $\pm$ 2% Silvered mica 350 volts Lemco 1510	62813
C127	400 pf $\pm$ 2% Silvered mica 350 volts Lemco 1510	62813
C128	400 pf $\pm$ 2% Silvered mica 350 volts Lemco 1510	62813
C129	.0005 mfd $\pm$ 20% Moulded mica 350 volts Dubilier 635	62835
C130	.0005 mfd $\pm$ 20% Moulded mica 350 volts Dubilier 635	62835
C131	.1 mfd $\pm$ 20% Tubular paper 350 volts TMC S110138	62808
C132	6 pf $\pm$ 20% Silvered mica 350 volts Lemco 1510	62817
C133	2 mfd $\pm$ 20% Tubular paper 200 volts TMC S120016	62836
C134	2 mfd $\pm$ 20% Tubular paper 200 volts TMC S120016	62836
C135	.01 mfd $\pm$ 20% Tubular paper 350 volts Dubilier Minicap	62837
C136	.01 mfd $\pm$ 20% Tubular paper 350 volts Dubilier Minicap	62837
C137	.5 mfd $\pm$ 20% Tubular paper 350 volts TMC S120012	62816
C138	.01 mfd $\pm$ 20% Tubular paper 350 volts Dubilier Minicap	62837
C139	2 mfd $\pm$ 20% Tubular paper 200 volts TMC S120016	62836
C140	.1 mfd $\pm$ 20% Tubular paper 350 volts TMC S110138	62808
C141	.1 mfd $\pm$ 20% Tubular paper 350 volts TMC S110138	62808
C142	.1 mfd $\pm$ 20% Tubular paper 350 volts TMC S110138	62808
C143	100 mfd -20+50% Tub. Elect. Plug in 250 peak T.C.C. CE21H	62838
C144	100mfd -20+50% Tub. Elect. Plug in 250 peak T.C.C. CE21H	62838
C145	200 pf $\pm$ 2% Silvered mica 350 volts Lemco 1510	62833
C146	1 pf $\frac{1}{2}$ pf Silvered mica 350 volts Lemco 1510	62839
C147	100pf $\pm$ 10% Silvered mica 350 volts Lemco 1510	62840
C148	27.5 pf Air trimmer, Stratton 588	62582
C149	100 pf $\pm$ 10% Silvered mica 350 volts Lemco 1510	62840
C150	.01 mfd $\pm$ 20% Tubular paper 150 volts Dubilier 400	62812
C151	.01 mfd $\pm$ 20% Tubular paper 350 volts Dubilier minicap	62837
C152	.01 mfd $\pm$ 20% Tubular paper 350 volts Dubilier Minicap	62837
C153	6 pf $\pm$ 20% Silvered Mica 350 volts Lemco 1510	62817
C154	.01 mfd $\pm$ 20% Tubular paper 150 volts Dubilier 400	62812
C155	6 pf $\pm$ 20% Silvered mica 350 volts Lemco 1510	62817
C156	20 pf $\pm$ 10% Tubular ceramic 350 volts Erie N750	62827



REF.	DESCRIPTION	MR NO
C157	20 pf $\pm$ 10% Tubular ceramic 350 volts Erie N750	62827
C158	20 pf $\pm$ 10% Tubular Ceramic 350 volts Erie No.N750	62827
C159	400 pf $\pm$ 2% Silvered mica 350 volts Lemco 1510	62813
C160		
C161	.5 mfd $\pm$ 20% Tubular paper 200 volts TMC S120012	62816
C162	.01 mfd $\pm$ 20% Tubular paper 350 volts Dubilier Minicap	62837
C163	.01 mfd $\pm$ 20% Moulded mica 350 volts Dubilier 672	62841
C164	.05 mfd $\pm$ 20% Tubular paper 500 volts TMC S34553	62807
C165	.5 mfd $\pm$ 20% Tubular paper 200 volts TMC S110012	62816
C166	4-33 pf Air Trimmer, Stratton 4126P	62579
C167	80 pf $\pm$ 10% Silvered mica 350 volts Lemco 1510	62815
C168	.5 mfd $\pm$ 20% Tubular paper 200 volts TMC S120012	62816
C169	3-23 pf Air Trimmer, Stratton 3909PA	62581
C170	200 pf $\pm$ 2% Silvered mica 350 volts Lemco 1510	62833
C171	30 mfd -20 + 50% Tub.Elec. 15 volts TCC CE71B	62842
C172	30mfd -20 + 50% Tub.Elec. 15 volts TCC CE71B	62842
C173	.5 mfd $\pm$ 20% Tubular paper 200 volts TMC S120012	62816
C174	.5 mfd $\pm$ 20% Tubular paper 200 volts TMC S120012	62816
C175	.01 mfd $\pm$ 20% Moulded mica 350 volts Dubilier 672	62841
C176	.5 mfd $\pm$ 20% Tubular paper 200 volts TMC S120012	62816
C177	20pf $\pm$ 10% Silvered mica 350 volts Lemco 1510	62818
C178	.01 mfd $\pm$ 20% Tubular paper 350 volts Dubilier Minicap	62837
C179	.01 mfd $\pm$ 20% Tubular paper 350 volts Dubilier Minicap	62837
C180	.01 mfd $\pm$ 20% Tubular paper 350 volts Dubilier Minicap	62837
C181	.5 mfd $\pm$ 20% Tubular paper 200 volts TMC S120012	62816
C182	.5 mfd $\pm$ 20% Tubular paper 200 volts TMC S120012	62816
C183	.5 mfd $\pm$ 20% Tubular paper 200 volts TMC S120012	62816
C184	.001 mfd $\pm$ 20% Moulded mica 250 volts Dubilier 690W	62843
C185	.5 mfd $\pm$ 20% Tubular paper 200 volts TMC S120012	62816
C186	20 pf $\pm$ 10% Silvered mica 350 volts Lemco 1510	62818
	<u>RESISTORS</u>	
R1	3.0 megohms $\pm$ 10% $\frac{1}{2}$ watt Morganite type T	66776
R2	560 ohms $\pm$ 20% $\frac{1}{2}$ watt Morganite type T	66748

COMPONENT LIST FOR IMR54/5406

SHEET No. 6

REF.	DESCRIPTION	MR NO
R3	.1 Megohm $\pm$ 10% $\frac{1}{2}$ watt Morganite type T	66777
R4	.18 megohm $\pm$ 10% $\frac{1}{2}$ watt Erie type 16	66771
R5	.27 megohm $\pm$ 10% $\frac{1}{2}$ watt Erie type 16	66769
R6	.27 megohm $\pm$ 10% $\frac{1}{2}$ watt Erie type 16	66769
R7	.27 megohm $\pm$ 10% $\frac{1}{2}$ watt Erie type 16	66769
R8	.33 megohm $\pm$ 10% $\frac{1}{2}$ watt Erie type RMA 8	66727
R9	68 ohms $\pm$ 20% $\frac{1}{2}$ watt Erie type 16	66735
R10	4700 ohms $\pm$ 20% $\frac{1}{2}$ watt Morganite type T	66761
R11	2,200 ohms $\pm$ 20% $\frac{1}{2}$ watt Erie type 16	66755
R12	.33 megohm $\pm$ 10% $\frac{1}{2}$ watt Erie RMA 8	66727
R13	560 ohms $\pm$ 20% $\frac{1}{2}$ watt Erie RMA 8	66728
R14	68 ohms $\pm$ 20% $\frac{1}{2}$ watt Erie type 16	66735
R15	560 ohms $\pm$ 20% $\frac{1}{2}$ watt Erie RMA 8	66728
R16	470 ohms $\pm$ 20% $\frac{1}{2}$ watt Erie type 16	66746
R17	560 ohms $\pm$ 20% $\frac{1}{2}$ watt Erie RMA 8	66728
R18	.47 megohm $\pm$ 10% $\frac{1}{2}$ watt Erie type 16	66768
R19	.18 megohm $\pm$ 10% $\frac{1}{2}$ watt Erie type 16	66771
R20	.27 megohm $\pm$ 10% $\frac{1}{2}$ watt Erie type 16	66769
R21	.27 megohm $\pm$ 10% $\frac{1}{2}$ watt Erie type 16	66769
R22	47,000 ohms $\pm$ 20% $\frac{1}{2}$ watt Erie RMA 8	66504
R23	47,000 ohms $\pm$ 20% $\frac{1}{2}$ watt Erie RMA 8	66504
R24	15,000 ohms $\pm$ 20% $\frac{1}{2}$ watt Erie RMA 8	66291
R25	2,200 ohms $\pm$ 20% $\frac{1}{2}$ watt Erie RMA 8	66524
R26	150 ohms $\pm$ 20% $\frac{1}{2}$ watt Erie RMA 16	66740
R27	22,000 ohms $\pm$ 20% $\frac{1}{2}$ watt Erie RMA16	66764
R28	4,700 ohms $\pm$ 20% $\frac{1}{2}$ watt Erie RMA 16	66760
R29	3,300 ohms $\pm$ 20% $\frac{1}{2}$ watt Erie RMA 16	66758
R30	3,300 ohms $\pm$ 20% $\frac{1}{2}$ watt Erie RMA 16	66758
R31		
R32		
R33	1,000 ohms $\pm$ 20% $\frac{1}{2}$ watt Erie RMA 8	66476
R34	.18 megohm $\pm$ 10% $\frac{1}{2}$ watt Erie type 16	66771
R35	47,000 ohms $\pm$ 20% $\frac{1}{2}$ watt Erie type 16	66766

COMPONENT LIST FOR IMR54/5406

SHEET NO. 7

REF.	DESCRIPTION	MR NO.
R36	.47 megohm $\pm$ 10% $\frac{1}{2}$ watt Erie type 16	66768
R37	.27 megohm $\pm$ 10% $\frac{1}{2}$ watt Erie type 16	66769
R38	.33 megohm $\pm$ 10% $\frac{1}{2}$ watt Erie RMA.8	66727
R39		
R40		
R41		
R42	150 ohms $\pm$ 20% $\frac{1}{2}$ watt Erie type 16	66740
R43	560 ohms $\pm$ 20% $\frac{1}{2}$ watt Erie RMA.8	66728
R44	560 ohms $\pm$ 20% $\frac{1}{2}$ watt Erie RMA.8	66728
R45		
R46		
R47		
R48		
R49		
R50		
R51		
R52	.33 megohm $\pm$ 10% $\frac{1}{2}$ watt Erie RMA.8	66727
R53	.1 megohm $\pm$ 10% $\frac{1}{2}$ watt Erie type 16	66773
R54	.68 megohm $\pm$ 10% $\frac{1}{2}$ watt Erie type 16	66767
R55	.47 megohm $\pm$ 10% $\frac{1}{2}$ watt Erie type 16	66768
R56	22,000 ohms $\pm$ 20% $\frac{1}{2}$ watt Erie RMA.8	66520
R57	150 ohms $\pm$ 20% $\frac{1}{2}$ watt Erie type 16	66740
R58		
R59	1.0 megohm $\pm$ 10% $\frac{1}{2}$ watt Erie type 16	66774
R60	.47 megohm $\pm$ 10% $\frac{1}{2}$ watt Erie type 16	66768
R61	2.0 megohm $\pm$ 10% $\frac{1}{2}$ watt Erie type 16	66775
R62		
R63		
R64	22,000 ohms $\pm$ 20% $\frac{1}{2}$ watt Erie RMA.8	66520
R65	.47 megohm $\pm$ 10% $\frac{1}{2}$ watt Erie RMA.8	66530
R66	10,000 ohms $\pm$ 20% $\frac{1}{2}$ watt Erie type 16	66763
R67		
R68	47,000 ohms $\pm$ 20% $\frac{1}{2}$ watt Erie RMA.8	66504

COMPONENT LIST FOR IMR54/5406

SHEET NO. 8

REF.	DESCRIPTION	MR NO.
R69	.27 megohm $\pm$ 10% $\frac{1}{2}$ watt Erie type 16	66769
R70	.47 megohm $\pm$ 10% $\frac{1}{2}$ watt Erie type 16	66768
R71	.1 megohm $\pm$ 10% $\frac{1}{2}$ watt Erie RMA.8	66510
R72	.25 megohm $\pm$ 20% $\frac{1}{4}$ watt Stratton type 4529F	66770
R73	220 ohms $\pm$ 20% $\frac{1}{2}$ watt Erie type RMA.8	66522
R74	1,200 ohms $\pm$ 20% 6 watt Welwyn type AW 3112	66729
R75	47 ohms $\pm$ 20% $\frac{1}{2}$ watt Erie type 16	66733
R76	47,000 ohms $\pm$ 20% $\frac{1}{2}$ watt Erie type 16	66504
R77	1,000 ohms $\pm$ $\frac{1}{2}$ watt Erie RMA.8	66476
R78	12 ohms $\pm$ 20% $\frac{1}{2}$ watt Erie type 16	66731
R79	12 ohms $\pm$ 20% $\frac{1}{2}$ watt Erie type 16	66731
R80		
R81	1,000 ohms $\pm$ 20% $\frac{1}{2}$ watt Erie RMA.8	66476
R82	47 ohms $\pm$ 20% $\frac{1}{2}$ watt Erie RMA.8	66502
R83	10,000 ohms $\pm$ 20% $\frac{1}{2}$ watt Erie RMA.8	66331
R84	3,300 ohms $\pm$ 20% $\frac{1}{2}$ watt Erie RMA.8	66508
R85	560 ohms $\pm$ 20% $\frac{1}{2}$ watt Erie RMA.8	66728
R86	150 ohms $\pm$ 20% $\frac{1}{2}$ watt Erie type 16	66740
R87	1,500 ohms $\pm$ 20% $\frac{1}{2}$ watt Erie type 16	66754
R88	1,500 ohms $\pm$ 20% $\frac{1}{2}$ watt Erie type 16	66754
R89		
R90	68 ohms $\pm$ 20% $\frac{1}{2}$ watt Erie type 16	66735
R91		
R92	.33 megohm $\pm$ 10% $\frac{1}{2}$ watt Erie RMA.8	66727
R93	1,000 ohms $\pm$ 20% $\frac{1}{2}$ watt Erie type 16	66752
R94	.27 megohm $\pm$ 10% $\frac{1}{2}$ watt Erie type 16	66769
R95	.18 megohm $\pm$ 10% $\frac{1}{2}$ watt Erie type 16	66771
R96	47,000 ohms $\pm$ 20% $\frac{1}{2}$ watt Erie type 16	66766
R97	33,000 ohms $\pm$ 20% $\frac{1}{2}$ watt Erie type 16	66765
R98	680 ohms $\pm$ 20% $\frac{1}{2}$ watt Erie type 16	66749
R99		
R100	68 ohms $\pm$ 20% $\frac{1}{2}$ watt Erie type 16	66735

REF.	DESCRIPTION	MR NO.
R101	68 ohms $\pm$ 20% $\frac{1}{2}$ watt Erie type 16	66735
R102	.47 megohm $\pm$ 10% $\frac{1}{2}$ watt Erie type 16	66768
R103	560 ohms $\pm$ 20% $\frac{1}{2}$ watt Erie RMA.8	66728
R104	.5 megohm $\pm$ 20% $\frac{1}{4}$ watt Stratton type 4103P A.F.Control	65964
R105	560 ohms $\pm$ 20% $\frac{1}{2}$ watt Erie type RMA.8	66728
R106	10,000 ohms $\pm$ 20% $\frac{1}{2}$ watt Erie type RMA.8	66331
R107	6.85 ohms Stratton type D1793	66744
R108	6.85 ohms Stratton type D1793	66744
R109	6.85 ohms Stratton type D1793	66744
R110	6.85 ohms Stratton type D1793	66744
R111	6.85 ohms Stratton type D1793	66744
R112	6.85 ohms Stratton type D1793	66744
R113	13.6 ohms Stratton type D1794	66745
R114	2.3 ohms Stratton type D1795	66743
R115	13.6 ohms Stratton type D1794	66745
R116	39 ohms $\pm$ 20% $\frac{1}{2}$ watt Erie type 9	66732
R117	47 ohms $\pm$ 20% $\frac{1}{2}$ watt Erie type 9	66734
R118	68 ohms $\pm$ 20% $\frac{1}{2}$ watt Erie type 9	66736
R119	91 ohms $\pm$ 20% $\frac{1}{2}$ watt Erie type 9	66737
R120	120 ohms $\pm$ 20% $\frac{1}{2}$ watt Erie type 9	66739
R121	220 ohms $\pm$ 20% $\frac{1}{2}$ watt Erie type 9	66741
R122	470 ohms $\pm$ 20% $\frac{1}{2}$ watt Erie type 9	66747
R123	680 ohms $\pm$ 20% $\frac{1}{2}$ watt Erie type 9	66750
R124	1,000 ohms $\pm$ 20% $\frac{1}{2}$ watt Erie type 9	66751
R125	2,700 ohms $\pm$ 20% $\frac{1}{2}$ watt Erie type 9	66756
R126	3,300 ohms $\pm$ 20% $\frac{1}{2}$ watt Erie type 9	66757
R127	47 ohms $\pm$ 20% $\frac{1}{2}$ watt Erie type 9	66734
R128	91 ohms $\pm$ 20% $\frac{1}{2}$ watt Erie type 9	66737
R129	100 ohms $\pm$ 20% $\frac{1}{2}$ watt Erie type 9	66738
R130	120 ohms $\pm$ 20% $\frac{1}{2}$ watt Erie type 9	66739
R131	270 ohms $\pm$ 20% $\frac{1}{2}$ watt Erie type 9	66742
R132	470 ohms $\pm$ 20% $\frac{1}{2}$ watt Erie type 9	66747

REF.	DESCRIPTION	MR. NO.
R133	680 ohms $\pm 20\%$ $\frac{1}{2}$ watt Erie type 9	66750
R134	1,500 ohms $\pm 20\%$ $\frac{1}{2}$ watt Erie type 9	66753
R135	2,700 ohms $\pm 20\%$ $\frac{1}{2}$ watt Erie type 9	66756
R136	3,900 ohms $\pm 20\%$ $\frac{1}{2}$ watt Erie type 9	66759
R137	5,600 ohms $\pm 20\%$ $\frac{1}{2}$ watt Erie type 9	66762
R138	560 ohms $\pm 20\%$ $\frac{1}{2}$ watt Erie type RMA. 8	66728
R139	Thermistor S.T.C. type CZ-1	66800
<u>RELAY</u>		
REL.1	Siemens HS.100B - S.50/1	56108
<u>JACKS</u>		
J1	Igranio P.66	51234
J2	Igranio P.66	51234
<u>FUSES</u>		
F1	Belling Lee Cartridge 1 amp. type L.1055/1	54025
F2	Belling Lee Cartridge 1 amp. type L.1055/1	54025
<u>METER</u>		
M1	2 M/A F2A Butler to Drawing No.4369P	71574
<u>LOUDSPEAKER</u>		
LS1	R4/306/3.2 Goodman	61149
<u>RECTIFIERS</u>		
RECT.1	S.T.C. H45.12.1GZ, or Westinghouse T.14 B87	23084
RECT.2	WX3 Westinghouse	23085
<u>CRYSTALS</u>		
X1	465 Kcs. G.E.C. $\pm 1$ Kc JG/90/193	65420
X2	110 Kcs. G.E.C. $\pm 1$ Kc JG/90/193	65421
<u>TRANSFORMER</u>		
T1	Eddystone D1707 - IMR54 Specification	68187
<u>CHOKES</u>		
CH.1	Parmeko 5080/15A	63727
CH.2	S1 B.1730	63728
CH.3	S1 B.1730	63728
<u>VALVES</u>		
V1	Type 6BA6	31076
V2	Type 6BA6	31076
COMPONENT LIST FOR IMR54/5406		SHEET NO.11

REF:	DESCRIPTION	MR. NO:
V3	Type 6BE6	31079
V4	Type 6AU6	31075
V5	Type 6AU6	31075
V6	Type 6BA6	31076
V7	Type 6BA6	31076
V8	Type 6BA6	31076
V9	Type 6AT6	31080
V10	Type 25L6G	31327
V11	Type 6AL5	31074
V12	Type VR75	31861
	<u>COILS</u>	
L1 to L56	To I.M.R.C. Specification. To be ordered by schematic reference.	
	<u>SWITCHES</u>	
S1	Frequency Switch to I.M.R.C Specification	53286
S2	Selectivity Switch to I.M.R.C. Specification	53287
S3	R.F. Gain Control. A.B. Metal Products Ltd. S.P. 12 pos. Make Before Break. Minibank Tropical	53320
S4	B.F.O. On/Off Switch. N.S.F. Ltd., 3 amp 250v.S.P.S.T.	53321
S5	I.F. Gain Control. A.B. Metal Products Ltd., S.P. 12 pos. Make Before Break. Minibank Tropical	53320
S6	A.G.C. On/Off Switch. N.S.F. Ltd., 3 amp.250v.S.P.S.T.	53321
S7	Noise Limiter Switch. N.S.F. Ltd., On/Off.	53322
S8	Metering Switch. N.S.F. Ltd..	53323
S9	Main On/Off Switch. N.S.F. Ltd., 3 amp. 250v. D.P.D.T.	53324

ISSUE. 1. 21 - 8 - 52  
ISSUE. 2. 13 - 4 - 55

# IMR 54 RECEIVER.

OVERALL LENGTH -- 29 1/2"

OVERALL HEIGHT. -- 15"

OVERALL DEPTH. -- 18 3/4"

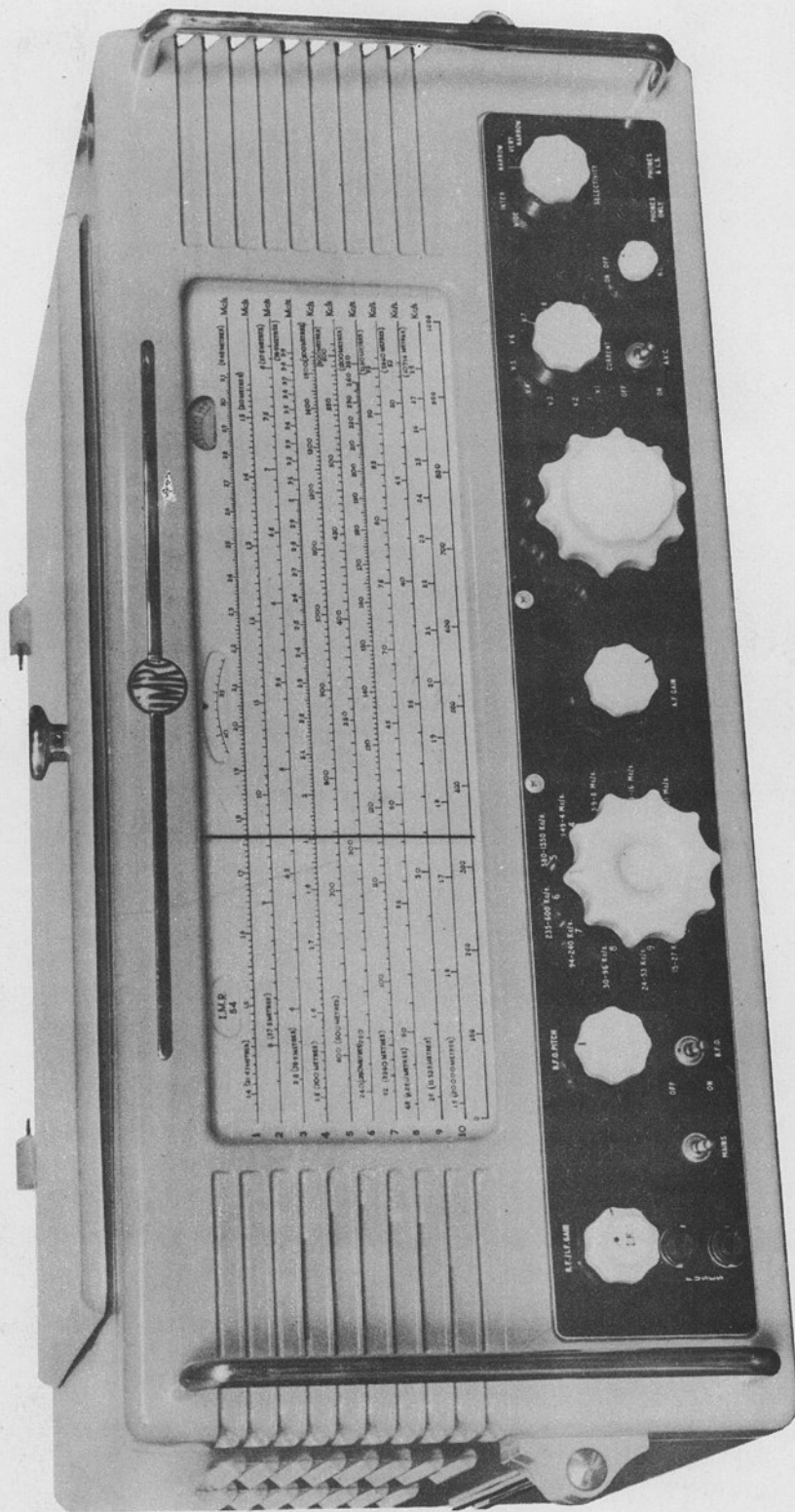

INTERNATIONAL MARINE RADIO CO. LTD. CROYDON.

DRAWN.  
*J. NORRIS.*

DATE.  
13-4-55.

DRG. No.

CHECKED.  
*[Signature]*

APPROVED.  
*[Signature]*

IM. 1592.



ASSEMBLY OF IMRC. RECEIVER AERIAL  
CO-AXIAL CONNECTOR

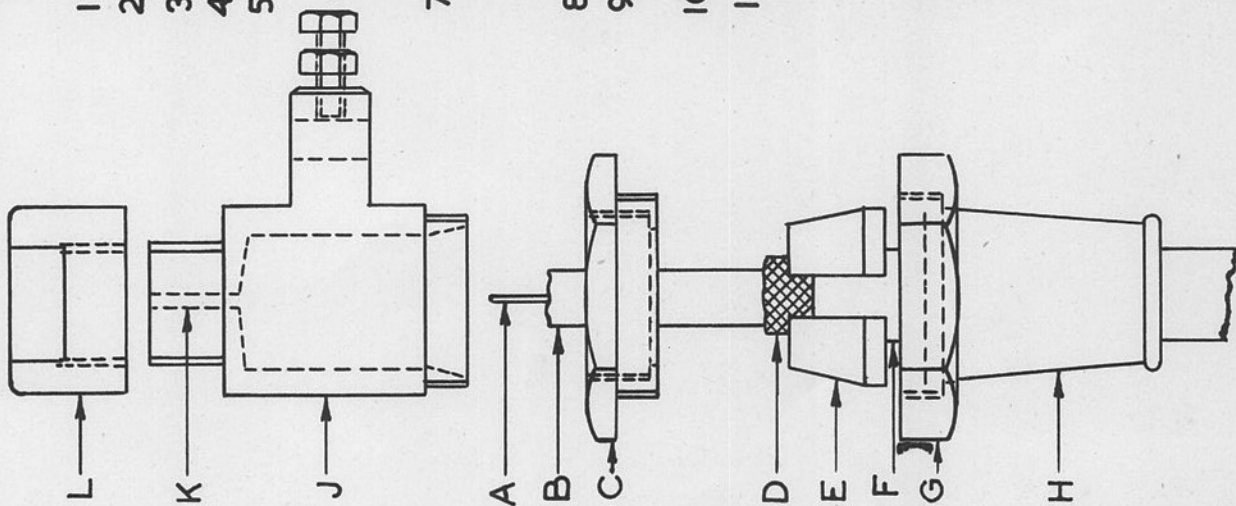

1. REMOVE  $\frac{1}{4}$ " OF OUTER P.V.C. COVERING 'F'.
2. REMOVE 2" OF BRAIDED SCREEN 'D'.
3. REMOVE  $\frac{1}{4}$ " OF POLYTHENE 'B' FROM CENTRE CONDUCTOR 'A'.
4. SLIP BACK NUT 'G' OVER END OF CABLE.
5. SLIP RUBBER BUSH 'H' OVER CABLE WITH TAPERED END POINTING DOWNWARDS.
6. PLACE THE TWO TAPERED FIBRE BUSHES 'E' ROUND THE CABLE IN SUCH A POSITION THAT THE TAPERED END JUST GRIPS THE BRAID 'D' WHILST THE LARGER END GRIPS 'F'.
7. NEXT PLACE LOCK NUT 'C' IN POSITION SHOWN WITH EXTERNAL THREAD POINTING DOWNWARDS. 'C' SHOULD THEN BE FORCE OVER 'E'. (IT MAY BE NECESSARY TO USE A PAIR OF PLIERS FOR THIS PURPOSE.)
8. BRING 'H' & 'G' UPWARDS & SCREW 'C' & 'G' TOGETHER.
9. REMOVE THE END NUT 'L' FROM THE MAIN BODY 'J' AND INSERT 'A' THROUGH THE HOLE 'K'.
10. SCREW 'J' & 'C' TIGHTLY TOGETHER.
11. CUT OFF CENTRE CONDUCTOR 'A' LEAVING A LENGTH OF  $\frac{3}{16}$ " WHICH SHOULD BE BENT OVER. THE END NUT 'L' SHOULD NOW BE REPLACED AND SCREWED DOWN HARD SO AS TO CLAMP THE BENT OVER CENTRE CONDUCTOR AND ENSURE GOOD CONTACT.  
SOLDERING OF 'A' TO 'K' IS NOT RECOMMENDED AS HEATING 'J' MAY MELT THE POLYTHENE INSULATION.

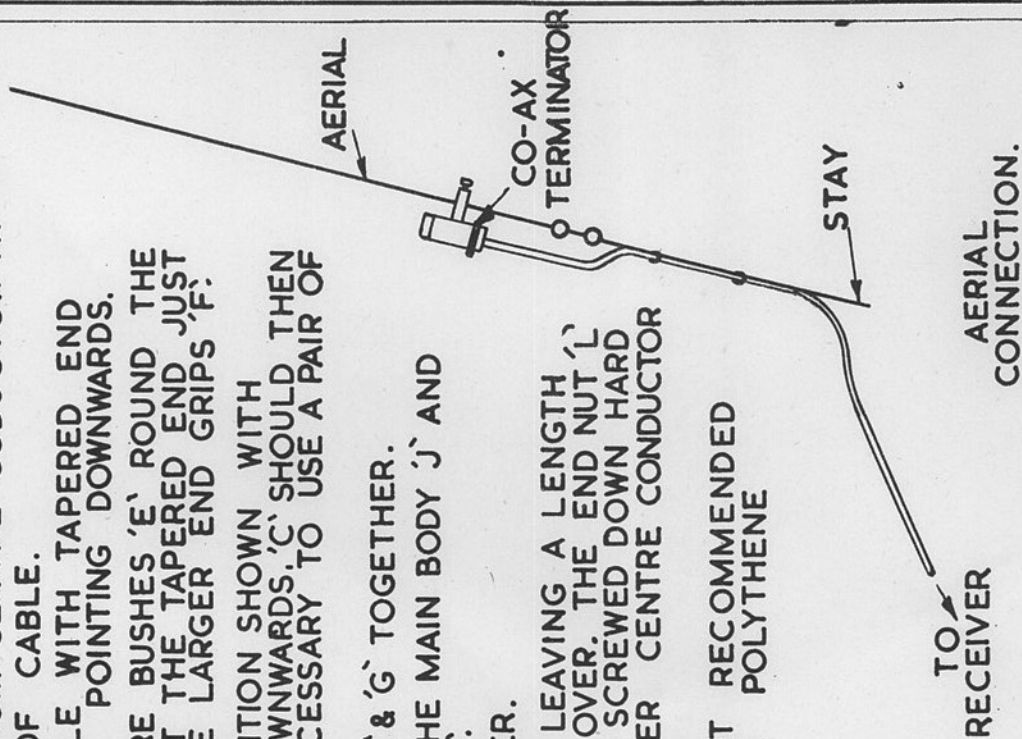

DATE

I.M.R. Co. Ltd.

SM. 1169

# IMR. 54 RECEIVER

D.C. MAINS DROPPING RESISTANCE. (M.R. 66717)

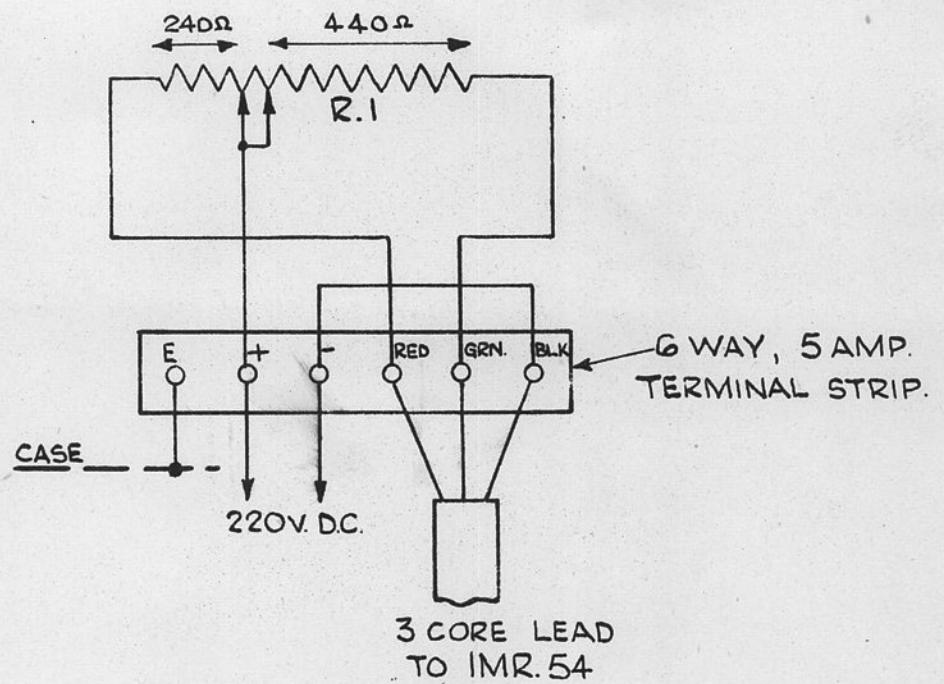

R.1. - 700Ω, 0.5 AMP. ADJUSTABLE, TROPICAL FINISH  
STOCK No. 66730.

INTERNATIONAL MARINE RADIO Co. LTD.	
DRAWN D.L.M.	DATE 28-10-52
CHECKED	APPROVED
IM.1600	

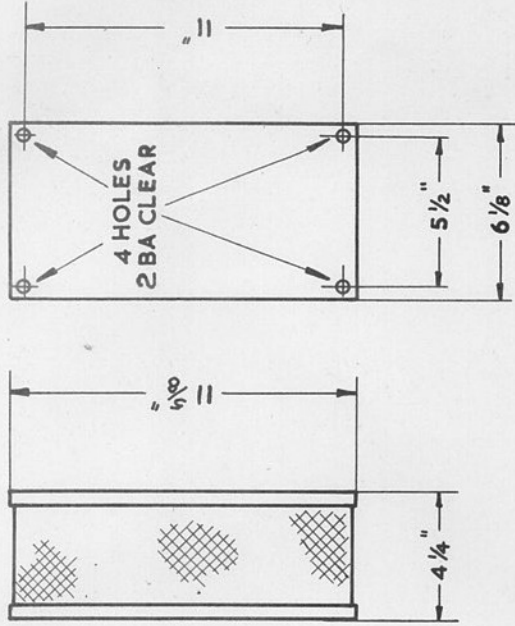
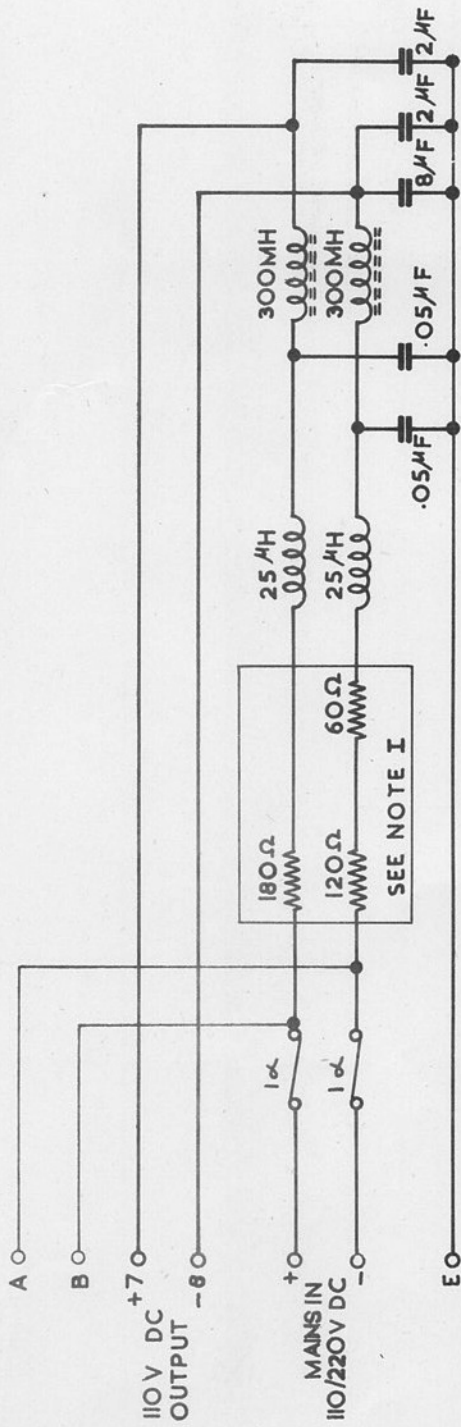

**NOTE 1.**  
 THE MAINS DROPPER  
 IS REQUIRED FOR  
 220V DC MAINS  
 ONLY AND SHOULD  
 BE SET AS SHOWN.  
 FOR 110V OPERATION  
 ALL RESISTORS SHOULD  
 BE SHORTED OUT.

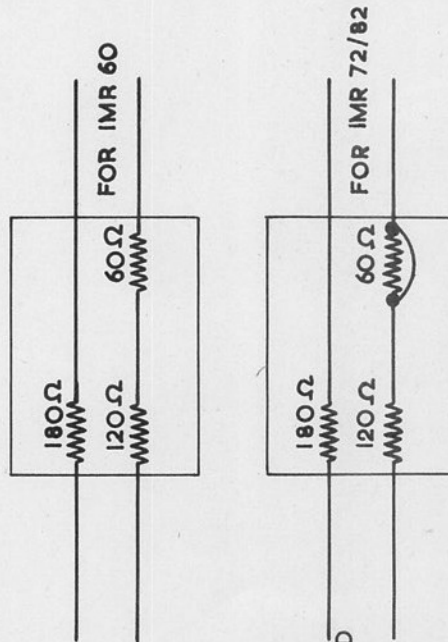

**NOTE 2.** RE. IMR.54.  
 WHEN THIS FILTER IS FITTED IN THE MAINS LEADS TO  
 IMR.54, ALL RESISTORS SHOULD BE SHORTED OUT  
 FOR 110V & 220V MAINS. A SEPARATE SERIES RESISTOR  
 MUST BE FITTED FOR 220V MAINS.—SEE DRAWING IM.1600.

**IMR. 60 MAINS FILTER UNIT**  
**MR. 19948**

INTERNATIONAL MARINE RADIO CO. LTD. CROYDON.	
DRAWN <i>Kedley</i>	DATE 31.7.58
CHECKED	APPROVED <i>[Signature]</i>
DRG. NO. IM. 1814	

115 V. 1 PHASE MAINS SUPPLY

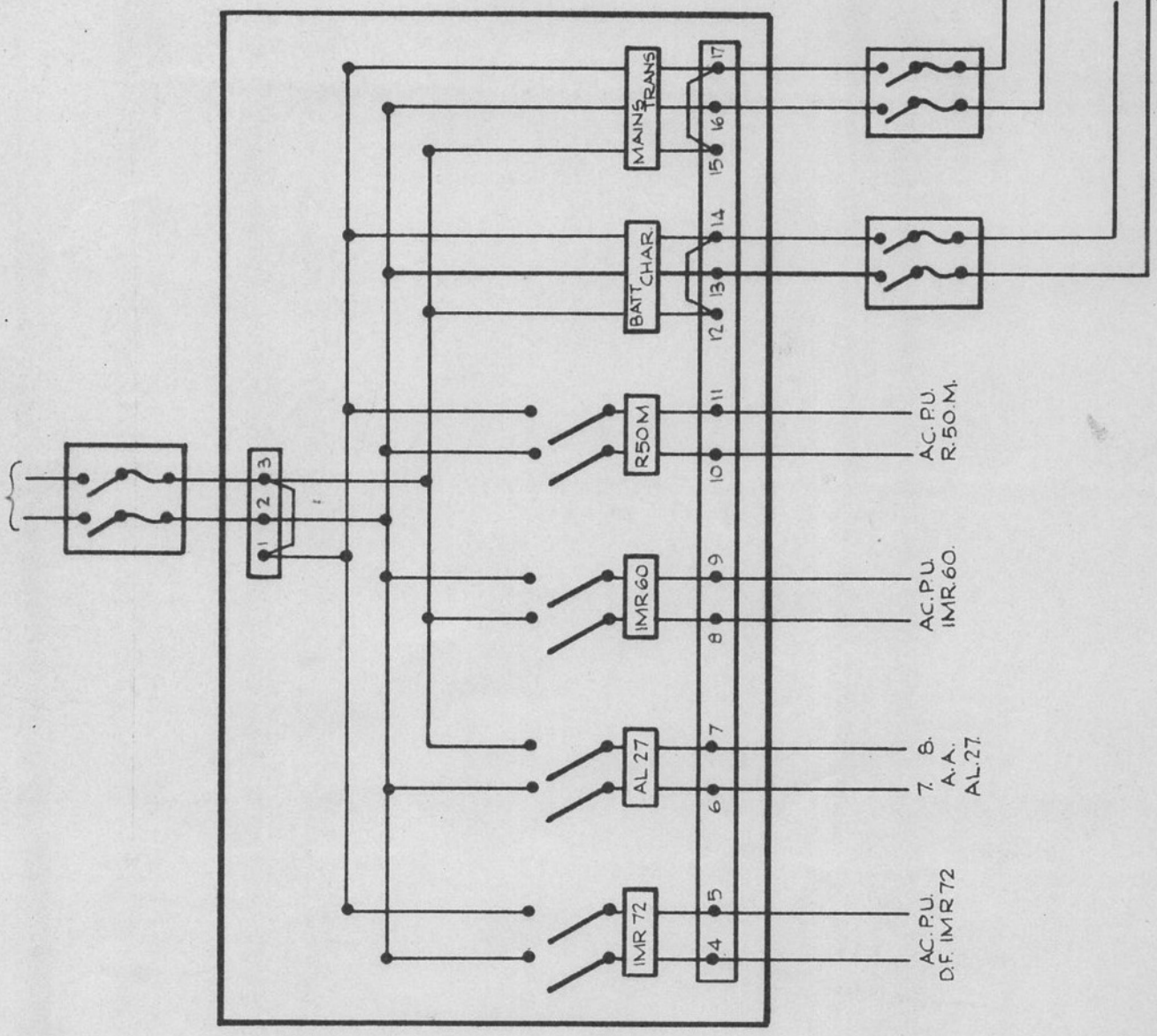

115.V. MAINS SUPPLY UNIT  
SINGLE PHASE

INTERNATIONAL MARINE RADIO CO. LTD. CROYDON.	
DRAWN M. K. C.	DATE 10. 2. 58.
CHECKED M. A. B.	APPROVED
DRG. NO. IM. 1728/1/B.	

**RECEIVER AERIAL DISTRIBUTION UNIT**  
**MR. 53285**

ISSUE 1. 28-11-52.  
ISSUE 2. 21-6-56.  
TRANSFERRED TO 'B' S/P  
ISSUE 3. 10-7-57.  
C.I. WAS MICAMOLE  
ISSUE 4. 17-2-61

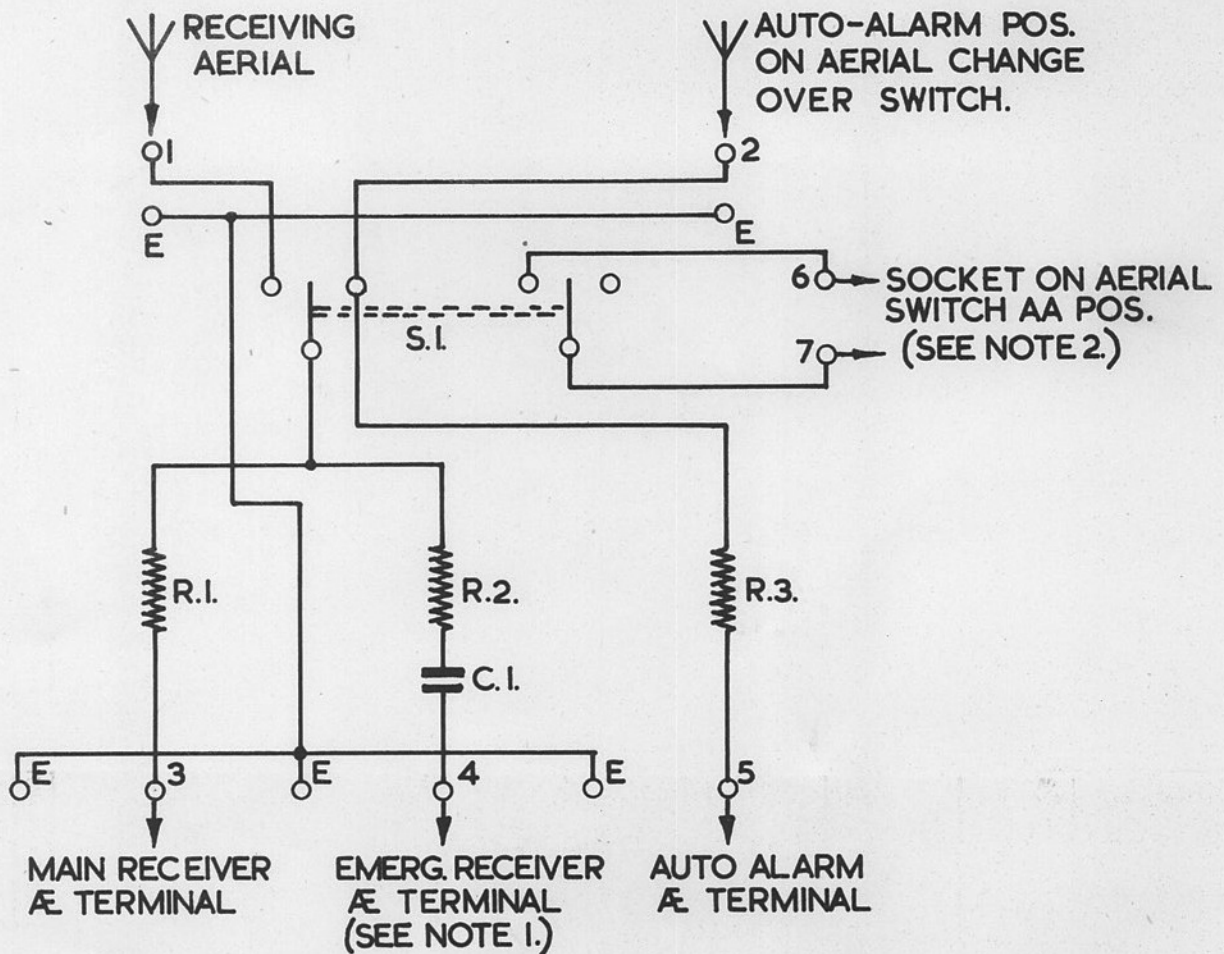

- C.1. - .001  $\mu$ F  $\pm$  20% M3U TCC. STOCK No. 62378  
 R.3. - 500  $\Omega$   $\pm$  10% ERIE RMA.8 " " 66720  
 R.2. - 250  $\Omega$   $\pm$  10% " TYPE.I. " " 66725  
 R.1. - 150  $\Omega$   $\pm$  10% " " " " 66726  
 S.1. - D.P.D.T. SWITCH " " 53212

**NOTE.1.** WHEN THE AUTO ALARM ALSO SERVES AS THE EMERGENCY RECEIVER TERMINAL 4 (INSTEAD OF 5) IS TO BE CONNECTED TO  $\bar{A}$  TERMINAL ON THE AUTO ALARM.

**NOTE.2.** CABLING TO TERMINALS 6 & 7 NOT REQUIRED WHEN SEPERATE EMERGENCY RECEIVER IS FITTED.

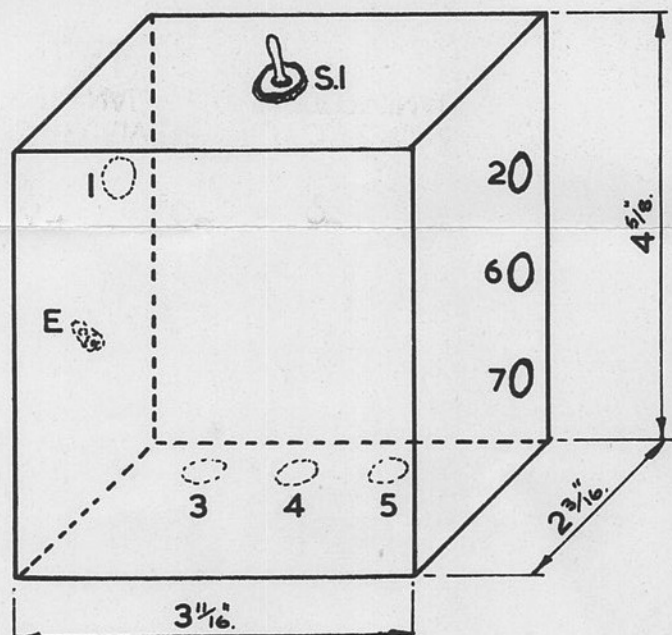

DRAWN P. TILLER	DATE 10-7-57	DRG. NO. IM. 1601
INTERNATIONAL MARINE RADIO CO. LTD. CROYDON.		

NOTE:- EARTH TO CASE ONLY.  
CHASSIS ALIVE.

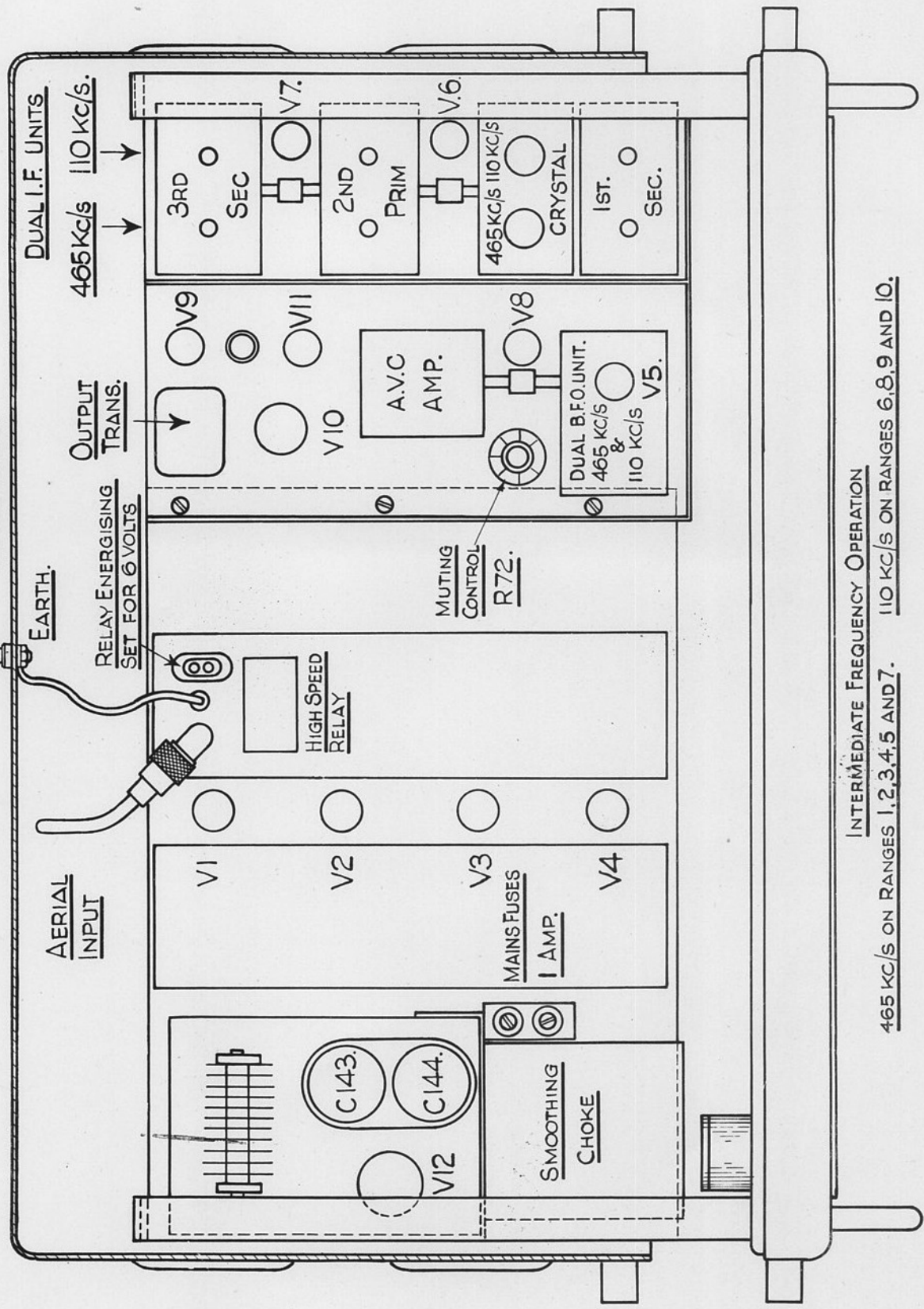

IMR.54 RECEIVER  
PLAN OF CHASSIS

INTERMEDIATE FREQUENCY OPERATION  
465 KC/S ON RANGES 1,2,3,4,5 AND 7. 110 KC/S ON RANGES 6,8,9 AND 10.

INTERNATIONAL MARINE RADIO CO. LTD.	
DRAWN JLM/AVS	DATE 28-8-52
CHECKED	APPROVED

IM.1594

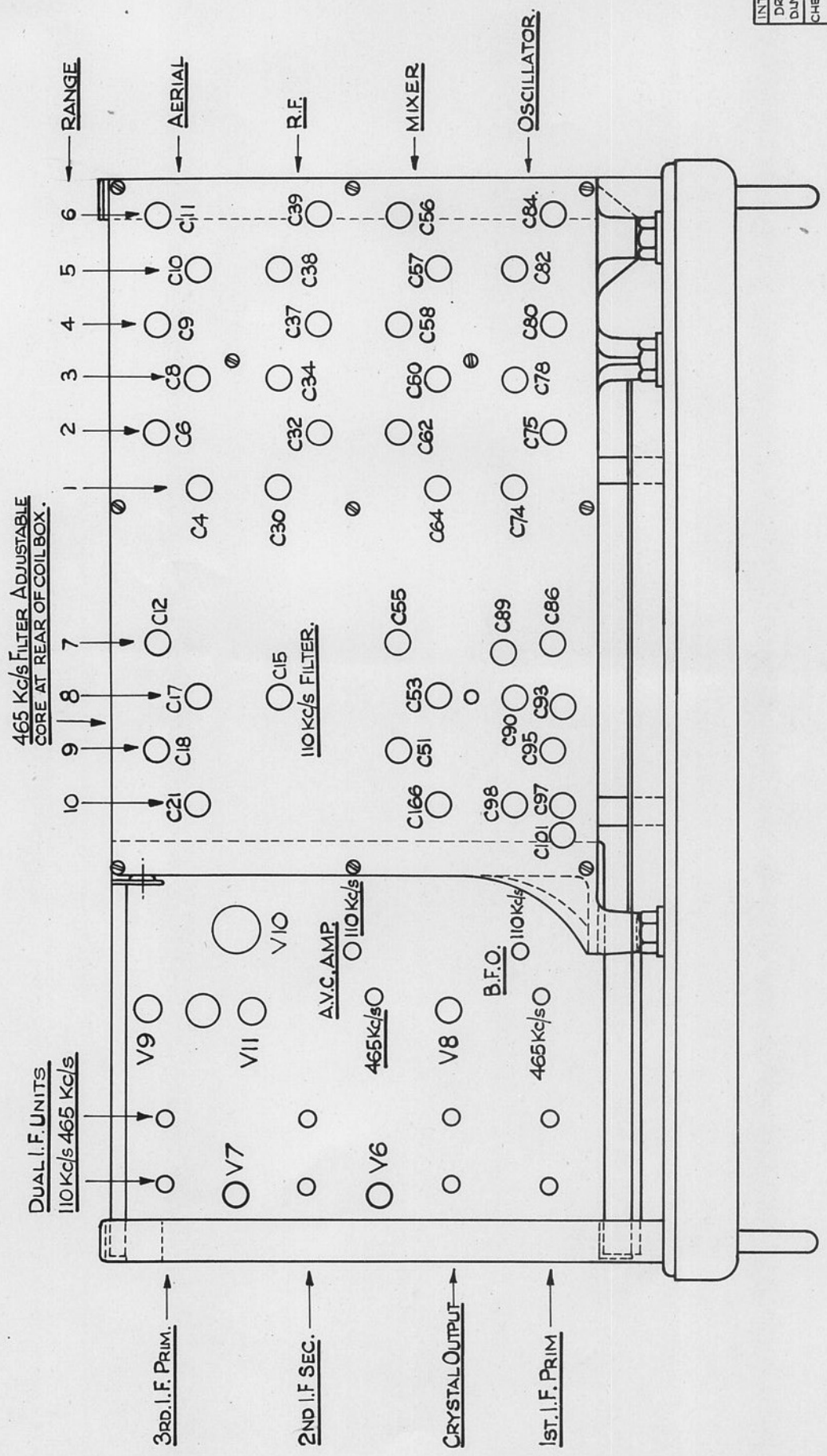

IMR. 54 RECEIVER.  
 UNDER CHASSIS VIEW.

INTERNATIONAL MARINE RADIO CO. LTD.	
DRAWN	DATE
DJM./AVS.	27-8-52
CHECKED	A. APPROVED

IM.1593

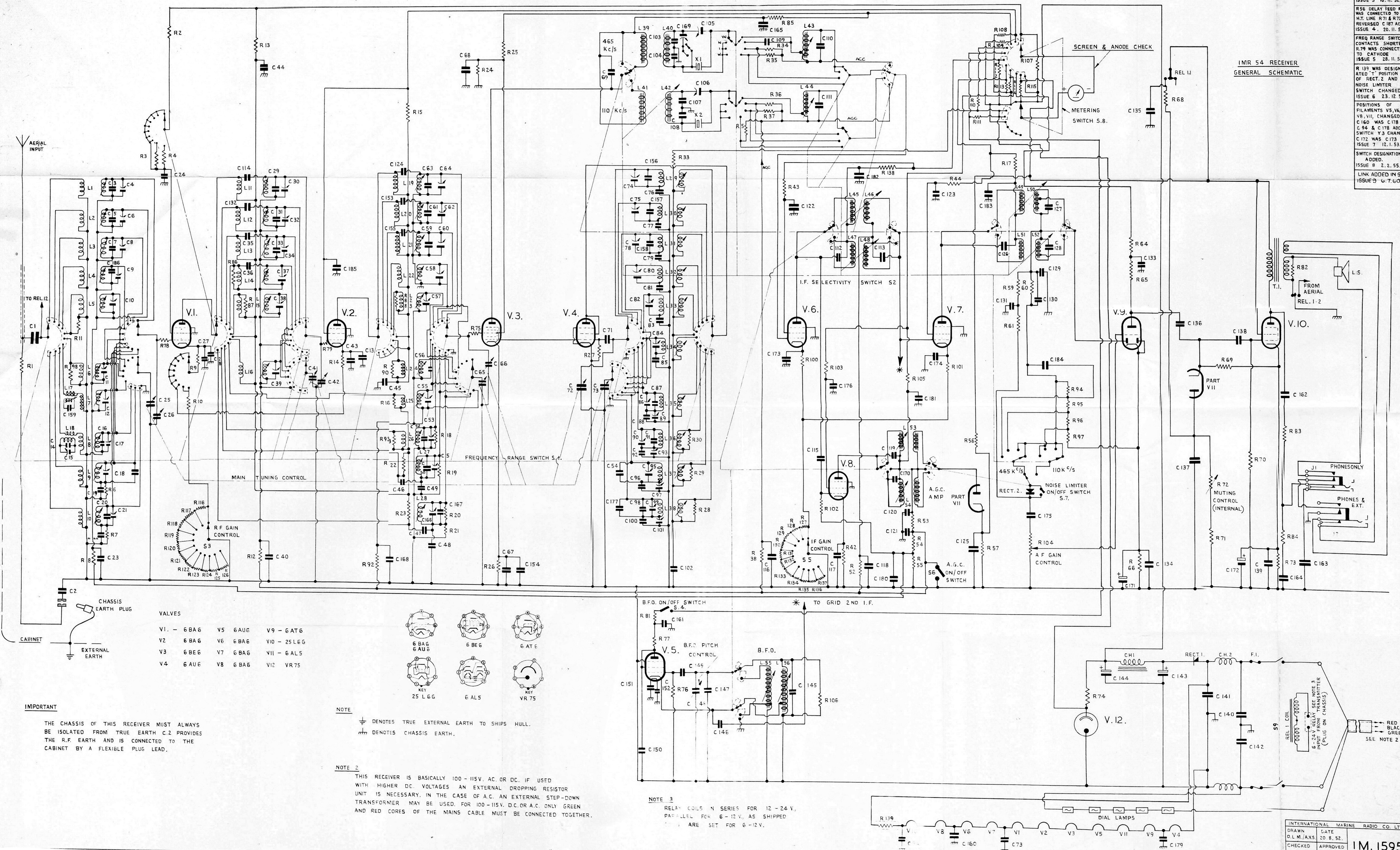

**IMR 54 RECEIVER  
GENERAL SCHEMATIC**

**VALVES**

V.1 - 6BA6	V.5 6AUG	V.9 - GAT6
V.2 6BA6	V.6 6BA6	V.10 - 25L6G
V.3 6BE6	V.7 6BA6	V.11 - 6AL5
V.4 6AU6	V.8 6BA6	V.12 VR75

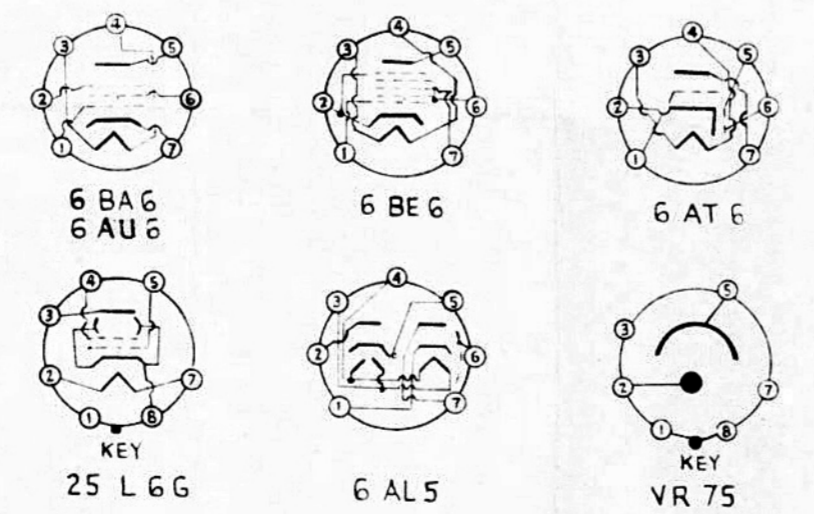

**NOTE**  
 DENOTES TRUE EXTERNAL EARTH TO SHIPS HULL.  
 DENOTES CHASSIS EARTH.

**NOTE 2**  
 THIS RECEIVER IS BASICALLY 100-115V. AC. OR DC. IF USED WITH HIGHER DC. VOLTAGES AN EXTERNAL DROPPING RESISTOR UNIT IS NECESSARY. IN THE CASE OF A.C. AN EXTERNAL STEP-DOWN TRANSFORMER MAY BE USED. FOR 100-115V. D.C. OR A.C. ONLY GREEN AND RED CORES OF THE MAINS CABLE MUST BE CONNECTED TOGETHER.

**NOTE 3**  
 RELAY COILS IN SERIES FOR 12-24 V.,  
 PARALLEL FOR 6-12 V., AS SHIPPED  
 ARE SET FOR 6-12 V.

**IMPORTANT**  
 THE CHASSIS OF THIS RECEIVER MUST ALWAYS BE ISOLATED FROM TRUE EARTH. C.2 PROVIDES THE R.F. EARTH AND IS CONNECTED TO THE CABINET BY A FLEXIBLE PLUG LEAD.

ISSUE 1. 20.8.52.  
 TECHNICAL MODIFICATIONS  
 ISSUE 2. 19.10.52.  
 TECHNICAL MOD'N  
 CCT. REF'S CORRECTED  
 ISSUE 3. 10.11.52.  
 R56 DELAY FEED RES.  
 WAS CONNECTED TO Y  
 HT. LINE R71 & R72  
 REVERSED C.187 ADDED  
 ISSUE 4. 20.11.52.  
 FREQ RANGE SWITCH  
 R.74 WAS CONNECTED  
 TO CATHODE  
 ISSUE 5. 28.11.52.  
 R.139 WAS DESIGNATED  
 'T' POSITION OF RECT. 2 AND  
 NOISE LIMITER  
 SWITCH CHANGED  
 ISSUE 6. 23.12.52.  
 POSITIONS OF  
 FILAMENTS V5, V6, V7,  
 V8, V11, CHANGED  
 C.160 WAS C.178  
 C.94 & C.178 ADDED  
 SWITCH V.3 CHANGED  
 C.172 WAS C.173  
 ISSUE 7. 12.1.53.  
 SWITCH DESIGNATIONS  
 ADDED.  
 ISSUE 8. 2.2.55.  
 LINK ADDED IN S.8  
 ISSUE 9. 6.7.60.