

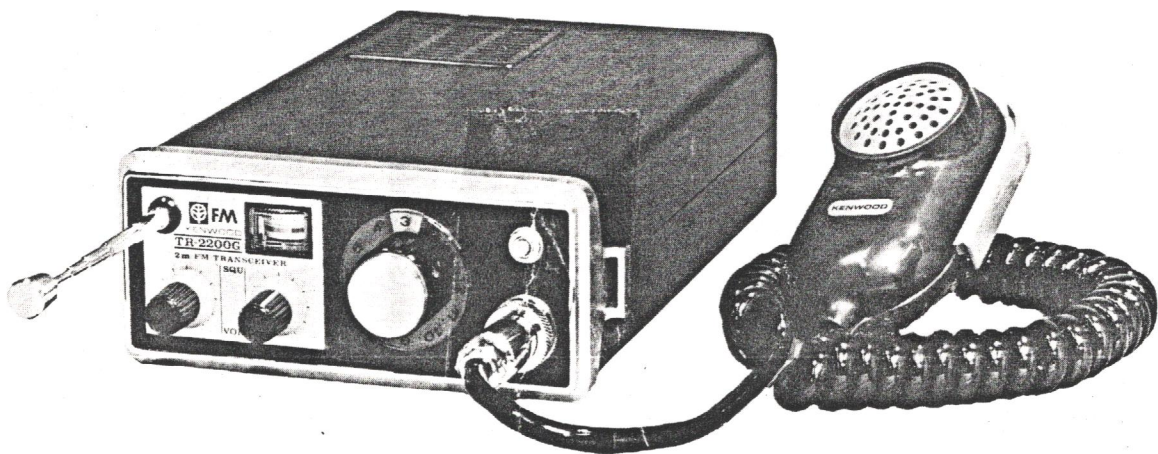

KENWOOD

SERVICE MANUAL

Model TR-2200G



2 METER FM HANDY TRANSCEIVER

CONTENTS

EXTERNAL VIEW	3
TOP VIEW/BOTTOM VIEW	4
ADJUSTMENTS	5 ~ 8
PARTS LIST	
TOTAL PARTS LIST	9, 10
POWER SUPPLY (X43-1080-00)/TONE (X52-1030-01)	10, 11
RX (X55-1030-61)	12 ~ 15
TX (X56-1080-00)	15 ~ 18
PC BOARD	
POWER SUPPLY/TONE	19
RX	20
TX	21
BLOCK DIAGRAM	22
SCHEMATIC DIAGRAM (SEMICONDUCTOR LEADS)	23
SPECIFICATIONS	24

EXTERNAL VIEW

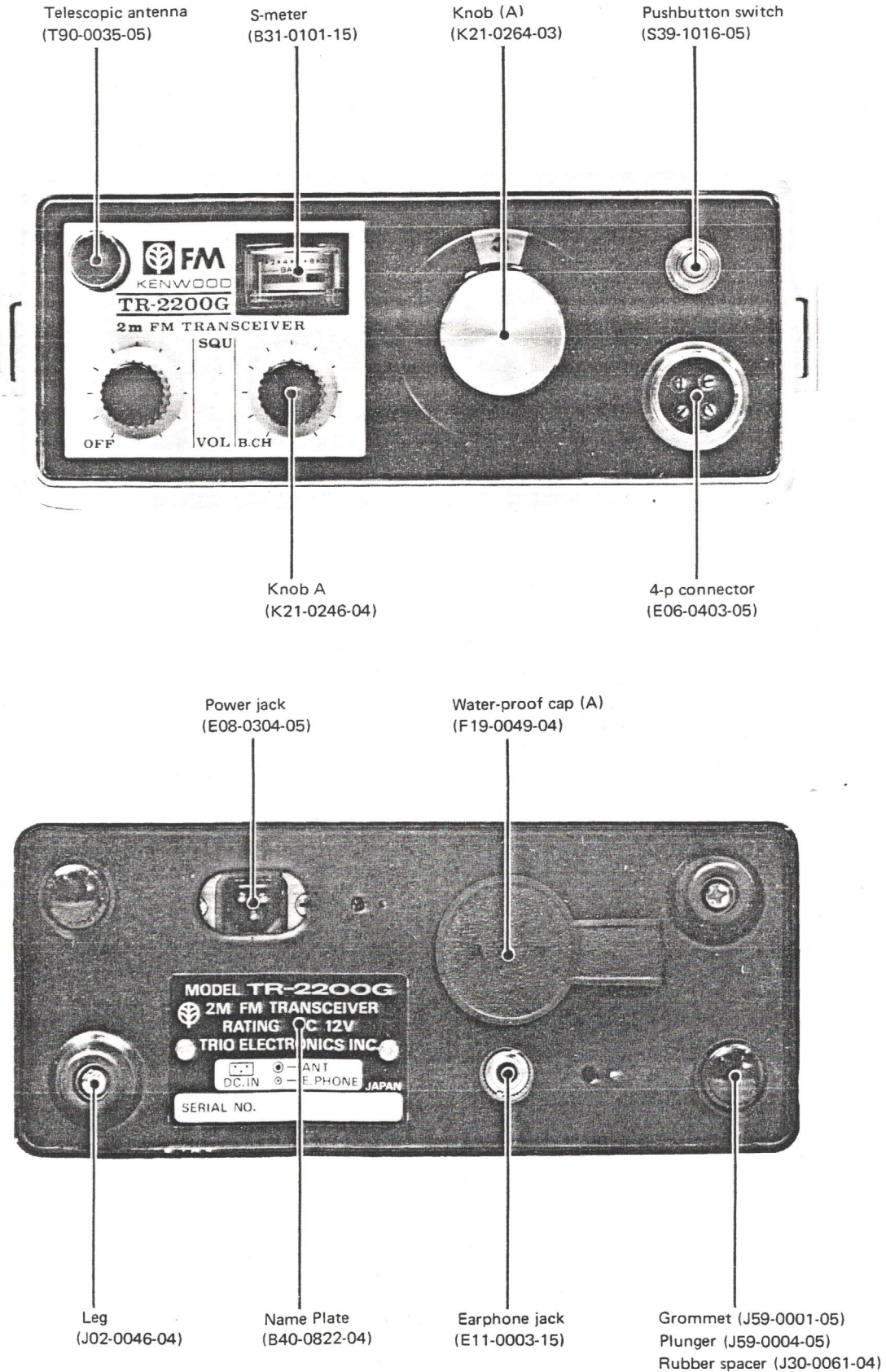

TOP VIEW

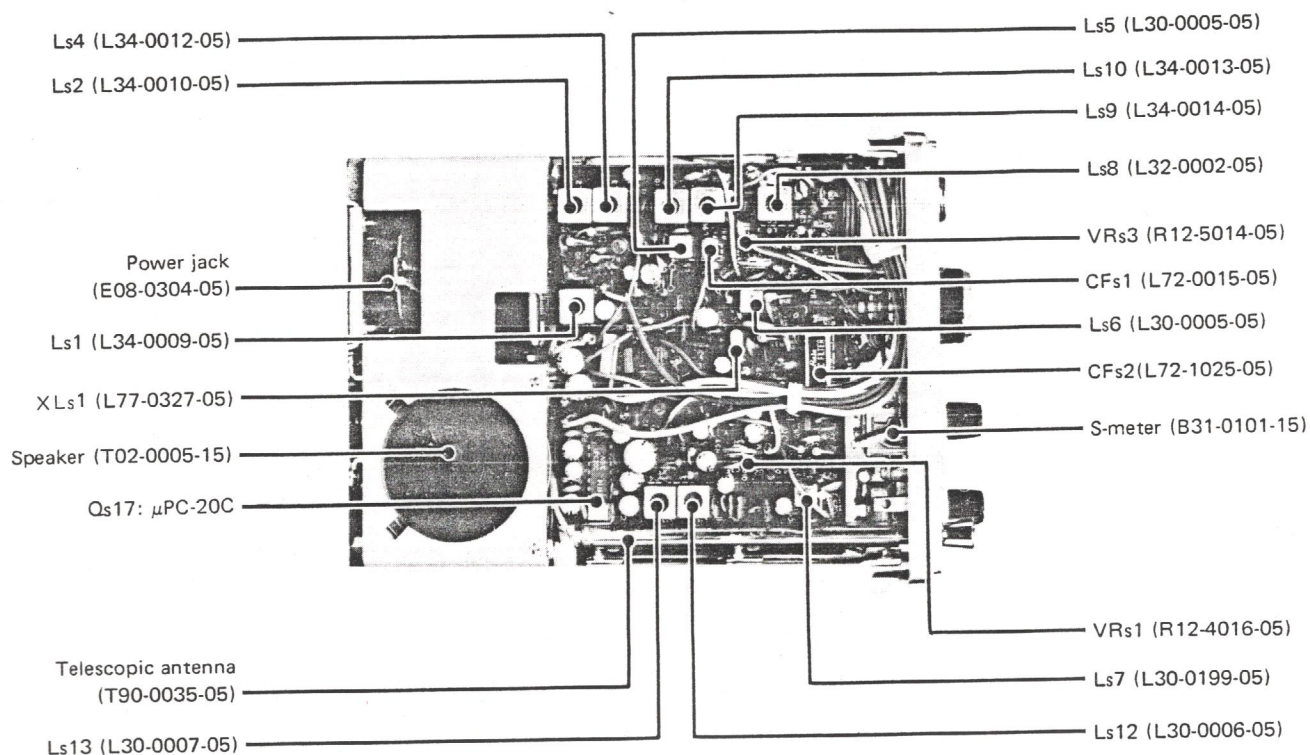

BOTTOM VIEW

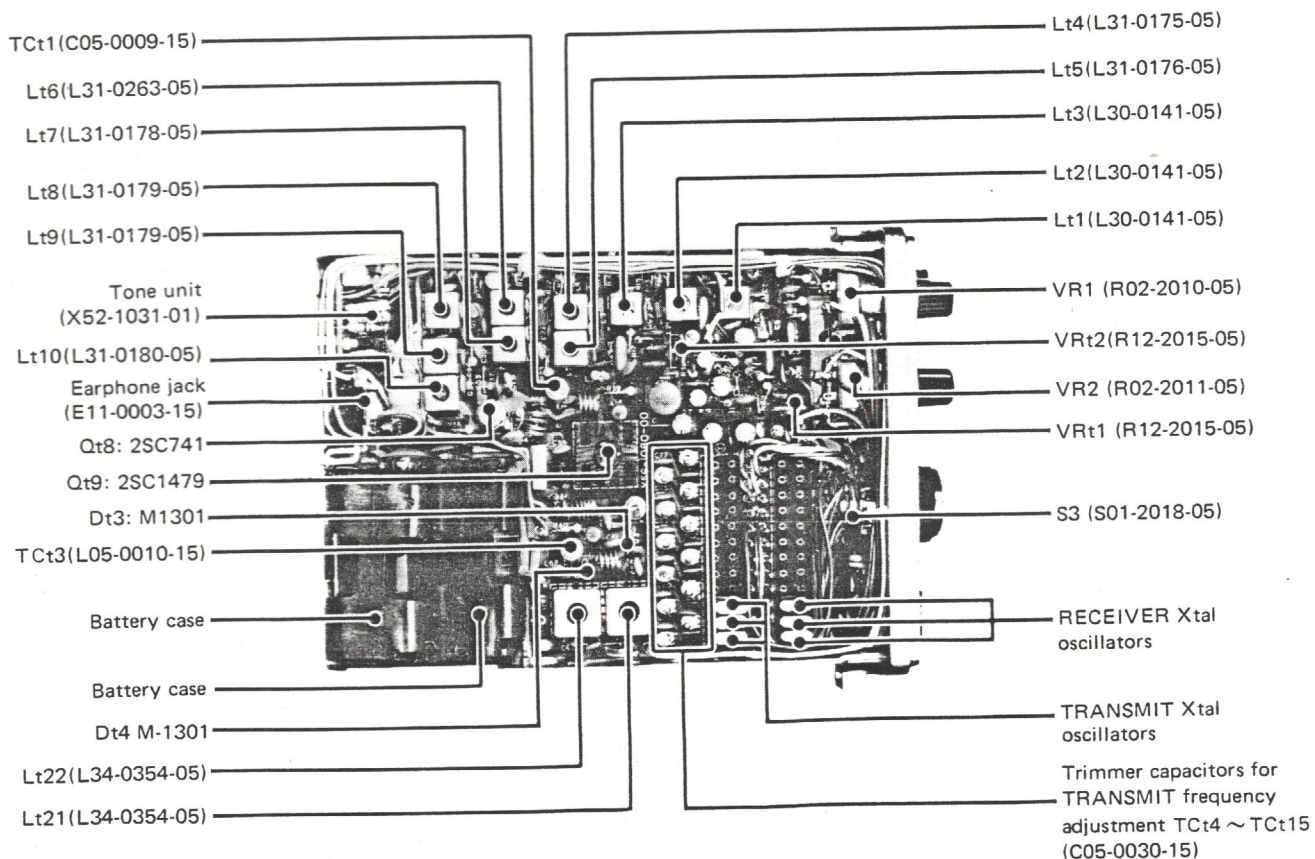

ADJUSTMENTS

CASE REMOVAL (See Fig. 1)

1. Release the rod snaps at the bottom of the case.
2. Pull the case out while pushing the external antenna connector.

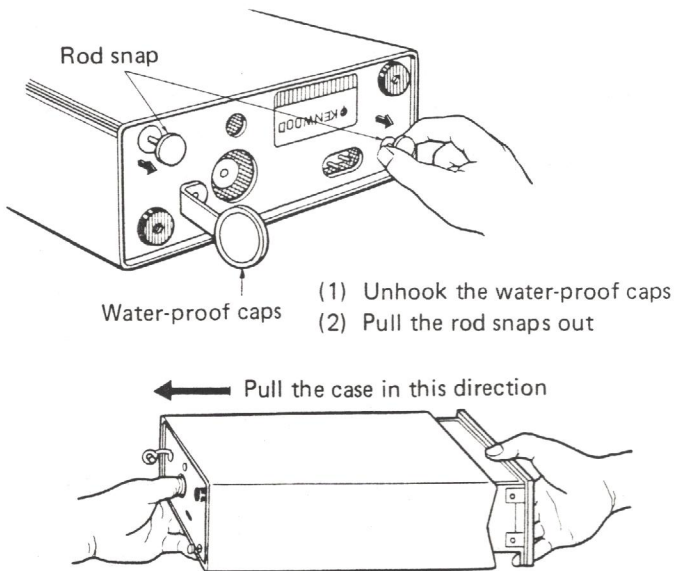

Fig. 1

PRINTED CIRCUIT BOARD REMOVAL (See Fig. 2)

1. Remove the screws securing the printed circuit board (PCB) in place.
2. Slide the PCB sidewise to facilitate its removal.
3. Position the transceiver with the panel toward you and lift the rear end of the PCB.

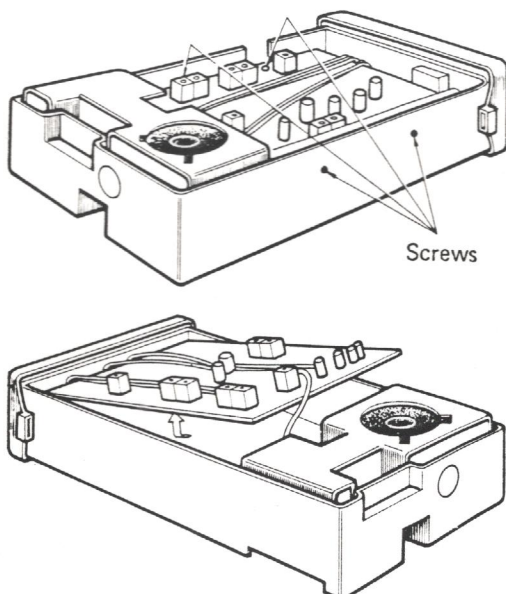

Fig. 2

Note:

To gain access to the TRANSMIT and RECEIVE circuits for repair work, the only part to be removed is the PCB in RECEIVE section: most of the circuits become accessible as you do so. An exception is the multiplier section, which is located behind the speaker: to repair the circuits of this section, disconnect the wires as shown in Fig. 3, remove the PCB securing screws and, as in the removal of RECEIVE section PCB, take out the multiplier PCB.

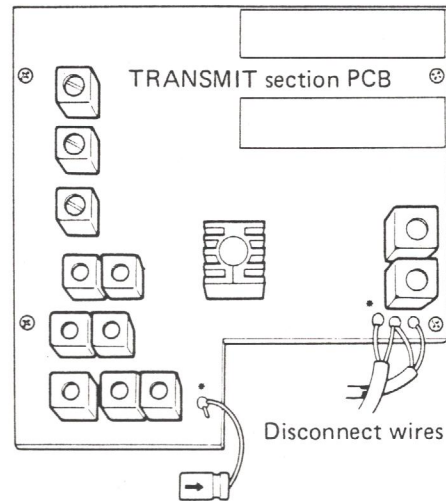

Fig. 3

REPAIRING THE MICROPHONE CONNECTOR

Correct connection of the microphone cord to the connector is shown in Fig. 4.

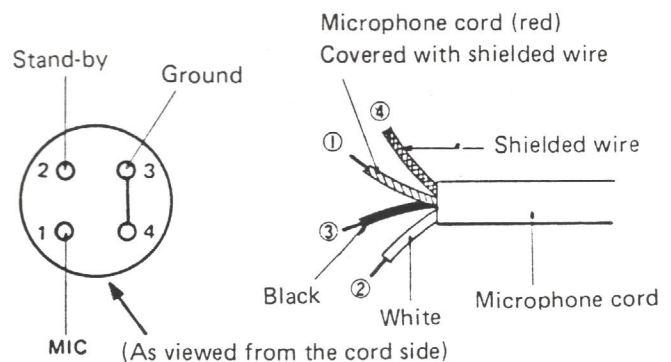

Fig. 4

RECEIVE SECTION ADJUSTMENT

Local Oscillator Coil

1. Tune the transceiver to about 145 MHz.
2. Turn the slug of coil Ls8 clockwise until oscillation stops.
3. Then turn the slug back 360 degrees for stable oscillation.

Sensitivity

1. Connect a signal generator to the external antenna connector.
2. Feed a signal to the transceiver (1 kHz modulation, 7 kHz frequency deviation).
3. Adjust coils Ls1, 2, 4, . . . 7, 9, 10 and TCt3 (mounted on the TRANSMIT section PCB) until the meter reads maximum with an optimum S/N ratio.

Discriminator Coil

1. Connect a signal generator to the external antenna connector and an oscilloscope to the output terminal.
2. Apply a signal (1 kHz modulation, 7 kHz frequency deviation, 10 dB $\approx 3\mu\text{V}$ output) to the transceiver.
3. Align coils Ls12 and 13 until output waveform is optimum on the oscilloscope.

S-Meter

1. Connect a signal generator to the external antenna connector.
2. Feed a 20 dB signal to the transceiver.
3. Adjust VRs1 until the meter deflects full scale (or reads 10).

Note:

Meter reading below full scale calls for readjustment of sensitivity.

Squelch

Set the channel selector knob to the channel that contains a crystal and confirm that there is no signal received. With any signal not being received adjust VRs2 until squelch opens between 9 and 2 o'clock.

Confirmations

1. The transceiver shall show no large difference in sensitivity for a supply voltage range of 10.4 to 15.2 volts.
2. Sensitivity difference shall be within the specification throughout the entire band including the band edges.
3. The transceiver shall not interfere with TV channel (176 to 182 MHz) after the local oscillator has been aligned.

TRANSMIT SECTION ADJUSTMENT

Note:

Use insulated screwdrivers for coil and trimmer adjustments.

Multiplier and final stage

1. Connect a 50-ohm power meter to the external antenna connector.
2. Set the channel selector of Model TR-2200G to a transmit frequency of 144.15 MHz and connect the instruments as shown in Fig. 5.

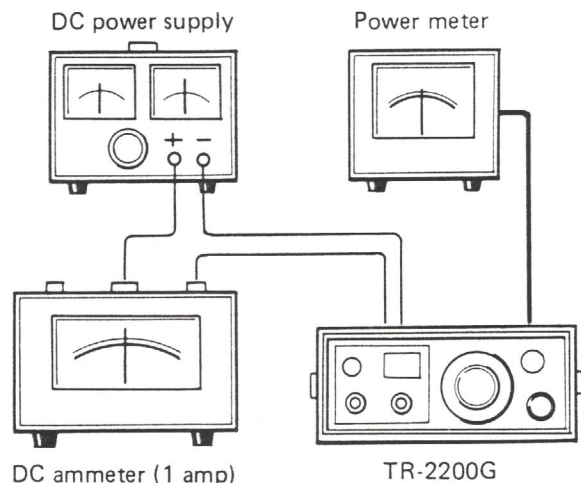

Fig. 5

3. Operate the transceiver in the transmitting state and adjust TCt1, 3 - 10 at a supply voltage of from 9 to 10 volts until the ammeter reads maximum.
4. Increase the supply voltage to 13 volts and adjust TCt1 and 2 for a maximum output.

Note:

TCt2 should be set to a point at which the output is approximately 5% down with a minimum current drain. This is to be achieved by reducing trimmer capacitance.

Modulation

1. Set the supply voltage to 13 volts and connect an audio generator to the microphone connector.
2. Modulate the carrier with a 1 kHz 5 mV signal and set the transceiver to the transmit state at 144.15 MHz.
3. Observe the waveform on an oscilloscope through a linear detector. Adjust Lt2 until and optimum output is obtained.

Adjustment Without Linear Detector

Apply a 3 mV, 1 kHz signal from the audio generator to the microphone input and connect an audio frequency VTVM to terminal T01 (X56-1080-00). Adjust VRt2 until the meter reads 360 mV. As still another method, another TR-2200G transceiver may be used as monitor.

Maximum Frequency Deviation

1. Connect an audio generator to the microphone connector.
2. Apply 1 kHz signal, 100 mV or greater, to the transceiver.
3. Adjust VRt2 to limit the frequency deviation to 12 kHz maximum.

TRANSMIT FREQUENCY (Fig. 6)

1. Prepare a pick-up coil, put it around the telescopic antenna, and connect its lead to the frequency counter.

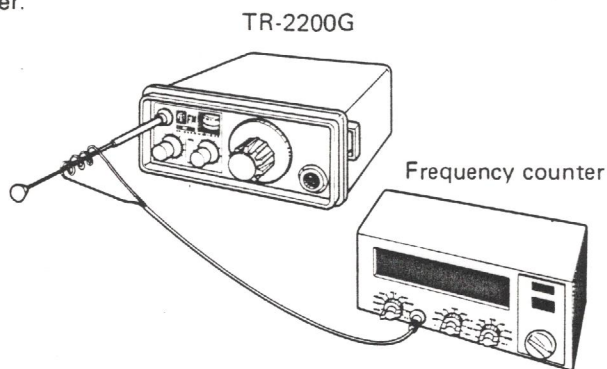

Fig. 6

2. Adjust each channel to the exact TRANSMIT frequency by means of associated frequency adjust trimmer.

Note:

If the available frequency counter does not measure 144 MHz, connect the counter to the base of Qt4 through a 0.01µF coupling capacitor. This set-up permits the counter to indicate fundamental frequencies. Adjustment tolerance is ±200 Hz.

Each TRANSMIT frequency is related to its fundamental frequency as follows:

CHANNEL	TRANSMIT FREQ. (MHz)	FUNDAMENTAL FREQ. (MHz)
1	144.150	12.012
2	144.200	12.017
3	144.250	12.021

RF Meter

1. Use 13 volt supply voltage.
2. Connect a power meter to the external antenna connector.
3. Adjust VRt3 and/or modify the position of the pick-up lead, located near Lt22, until the meter reads figure 8. (The same applies to the telescopic antenna.)

ADJUSTMENT OF OTHER CIRCUITRY

Battery Check Meter

1. Set the supply voltage to 10 volts.
2. Adjust VRs3 (on the RECEIVE section PCB), until the pointer deflects to between the red and black marks. (Be sure not to allow the screwdriver, used in this adjustment, to come in contact with the chassis and other circuits.)

Charging Circuit (Fig. 7)

1. Turn the transceiver power switch off.
2. Disconnect one of the snaps at the battery holder and measure the current.

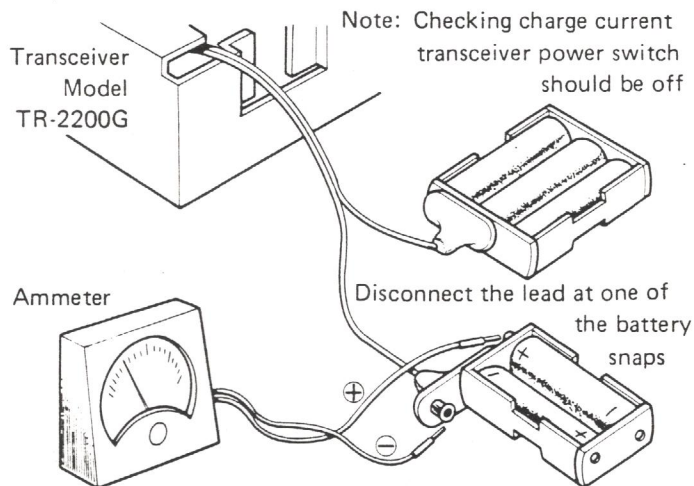

Fig. 7

Note:Charging current vs battery voltage curve for nickelcadmium cells is shown in Fig. 8. The charging current may deviate from this curve depending on the particular transceiver or cells used.

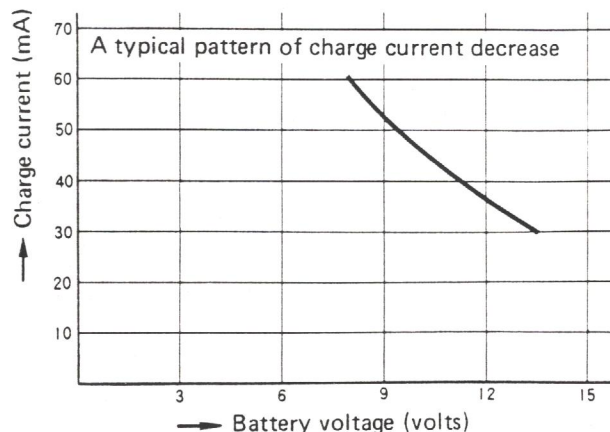

Fig. 8

Insufficient charge current will also result from defective cells. A defective cell or a cell which has an increased internal resistance, if any, can be found by replacing one cell at a time with new one while measuring their charge current. Fig. 9 shows the characteristic of the nickel-cadmium cell.

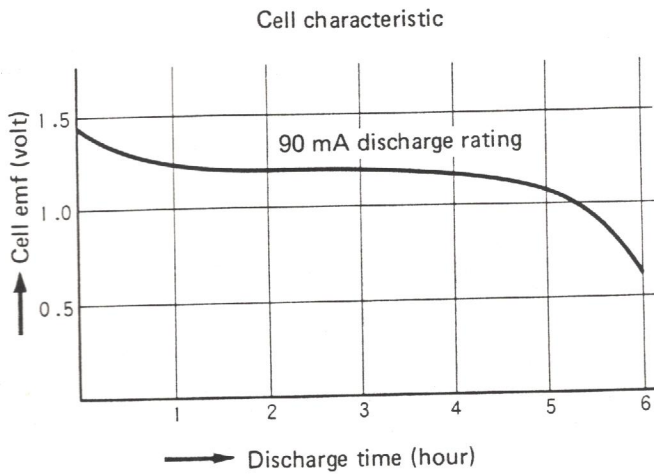

Fig. 9

Confirmations

1. Oral input through the microphone shall be clearly transmitted with sufficient modulation.
2. When the TRANSMIT frequency is varied across the band, there shall be no sign of abnormal oscillation at a supply voltage of from 10.4 to 15.2 volts as monitored by a television set, frequency counter or other devices.
3. The rated RF output shall be available at a standard supply voltage throughout the band.

Note:

Confirmations 1 and 2 should be made with the built-in telescopic antenna.

PARTS LIST

■ PARTS LIST OF TR-2200G

Ref. No.	Parts No.	Description	Remarks
CAPACITOR			
C301	CK45E1H102P	Ceramic 0.001 μ F +100% -0%	
C302	CE04W1C101(RL)	Electrolytic 100 μ F 16WV	
C304	CK45F1H103Z	Ceramic 0.01 μ F +80% -20%	
SEMICONDUCTOR			
D301		1S1555	
CRYSTAL OSCILLATOR			
-	L77-0253-05	Crystal oscillator (T 144.15MHz)	
-	L77-0254-05	Crystal oscillator (T 144.20MHz)	
-	L77-0255-05	Crystal oscillator (T 145.25MHz)	
-	L77-0256-05	Crystal oscillator (R 144.75MHz)	
-	L77-0257-05	Crystal oscillator (R 144.80MHz)	
-	L77-0258-05	Crystal oscillator (R 145.85MHz)	
POTENTIOMETER			
VR1	R02-2010-05	PC trimmer, 5k Ω , with switch, (A) for AF	
VR2	R02-2011-05	PC trimmer, 5k Ω , with switch, (B) for SQ	
SWITCH			
-	S01-2018-05	Rotary switch	
-	S39-1016-05	Pushbutton switch	
MISCELLANEOUS			
-	A01-0197-03	Case	
-	A09-0031-05	Vinyl case	
-	A10-0353-02	Chassis	
-	A20-0342-25	Panel	
-	A21-0129-04	Ornament panel (B)	
-	A21-0142-04	Ornament panel (A)	
-	B05-0123-04	Saran net (A)	
-	B31-0101-15	S-meter	
-	B40-0822-04	Name plate	
-	B42-0009-04	Passed sticker	
-	B50-1016-00	Instruction manual	
-	E04-0115-05	Type M connector (EXT. ANT)	
-	E06-0403-05	4-p connector (jack)	
-	E08-0216-05	AC connector (jack)	
-	E08-0304-05	Power jack	
-	E11-0003-15	Earphone jack	
-	E12-0001-05	Earphone plug	
-	E23-0015-04	Grounding lug x 2	
-	E23-0043-04	Antenna grounding lug	
-	E30-0109-05	AC power cord	
-	E30-0110-04	Battery snap	
-	E30-0220-05	Power plug with lead	
-	F09-0009-05	Battery case (A) x 4	
-	F09-0010-05	Battery case (B) x 2 x 6	
-	F19-0049-04	Water proof cap (A)	

Ref. No.	Parts No.	Description	Remarks
-	F20-0076-13	Insulator (B)	
-	F20-0081-03	Insulator (A)	
-	G02-0021-04	Battery retaining spring	
-	G02-0022-04	Spring plate x 2	
-	G11-0008-04	Cushion (B)	
-	G11-0034-04	Cushion	
-	G13-0014-04	Insulator (Rubber)	
-	G53-0013-04	Water-proof ring (A)	
-	G53-0014-04	Meter packing	
-	G53-0015-04	Antenna bushing	
-	H01-0969-13	Shipping case (internal)	
-	H03-0238-14	Shipping case (external)	
-	H10-0852-13	Foam styrol stuffing	
-	H10-0853-13	Foam styrol stuffing	
-	H20-0281-03	Protection cover	
-	H25-0079-04	Bag x 2	
-	H25-0123-04	Bag	
-	J02-0046-04	Leg x 2	
-	J21-0392-04	Lead holder	
-	J21-0448-04	Speaker mounting hardware x 2	
-	J21-0706-04	Meter mounting hardware	
-	J21-1130-04	Power jack mounting hardware	
-	J21-1131-04	Phone jack mounting hardware	
-	J30-0061-04	Rubber spacer x 2	
-	J31-0097-04	Collar x 2	
-	J41-0012-04	Antenna insulator	
-	J59-0001-05	Gromet x 2	
-	J59-0004-05	Plunger x 2	
-	J61-0019-05	Vinyl tie x 2	
-	K21-0264-03	Knob (A)	
-	K21-0246-04	Knob A x 2	
-	T02-0005-15	Speaker	
-	T91-0026-05	Microphone	
-	T90-0035-05	Telescopic antenna	
-	X43-1080-00	Power supply unit	
-	X52-1030-01	Tone unit	
-	X55-1030-61	RX unit	
-	X56-1080-00	TX unit	

■ PARTS LIST OF X43-1080-00 (POWER SUPPLY)

Ref. No.	Parts No.	Description	Remarks
RESISTOR			
R1	RC05GF2H330J	Carbon 33Ω ±5% 1/2W	

Ref. No.	Parts No.	Description	Remarks
SEMICONDUCTOR			
D1		DS-17	
MISCELLANEOUS			
—	A01-0207-04	Case	
—	A10-0365-04	Chassis	
—	A21-0145-04	Dress panel	
—	A49-0008-03	Side board B x 2	
—	E30-0034-05	Power cord	
—	E30-0220-05	Power plug with lead	
T1	L09-0098-15	Power transformer (220V/14V, 30 mA)	
—	J41-0011-05	Cord bushing	

■ PARTS LIST OF X52-1030-01 (TONE)

Ref. No.	Parts No.	Description	Remarks
CAPACITOR			
C1	CQ92M1H102K	Mylar 0.001 μ F \pm 10%	
C2, 3	CE04W1H010(RL)	Electrolytic 1 μ F 50WV	
C4	CE04W1C100(RL)	Electrolytic 10 μ F 16WV	
C5	CQ92M1H104K	Mylar 0.1 μ F \pm 10%	
C6	CE04W1C100(RL)	Electrolytic 10 μ F 16WV	
C7	CK45F1E103Z	Ceramic 0.01 μ F +80% -20%	
RESISTOR			
R1	PD14CY2E154J	Carbon 150k Ω \pm 5% 1/4W	
R2	PD14CY2E104J	Carbon 100k Ω \pm 5% 1/4W	
R3	PD14CY2E103J	Carbon 10k Ω \pm 5% 1/4W	
R4	PD14CY2E222J	Carbon 2.2k Ω \pm 5% 1/4W	
R5	PD14CY2E333J	Carbon 33k Ω \pm 5% 1/4W	
R6, 7	PD14CY2E472J	Carbon 4.7k Ω \pm 5% 1/4W	
R8	PD14CY2E102J	Carbon 1k Ω \pm 5% 1/4W	
R9	PD14CY2E332J	Carbon 3.3 k Ω \pm 5% 1/4W	
R10	PD14CY2E473J	Carbon 47k Ω \pm 5% 1/4W	
R11	PD14CY2E221J	Carbon 220 Ω \pm 5% 1/4W	
SEMICONDUCTOR			
Q1, 2		2SC458 (B)	
D1		WZ-090	
D2		1S1555	
OSCILLATOR			
X1	L79-0015-05	Piezo-tuning fork (T 1750 Hz)	
POTENTIOMETER			
VR1	R12-5024-05	PC trimmer 100k Ω (B)	

■ PARTS LIST OF X55-1030-61 (RX)

Ref. No.	Parts No.	Description			Remarks
CAPACITOR					
Cs1	CM93D1H050D(Z)	Hi-Q	5pF	±0.5pF	
Cs2	CM93D1H220J(Z)	Hi-Q	22pF	±5%	
Cs3	CK45B1H102K	Ceramic	0.001μF	±10%	
Cs4	CK45F1H103Z	Ceramic	0.01μF	+80%, -20%	
Cs5	CM93D1H050D(Z)	Hi-Q	5pF	±0.5pF	
Cs6	CK45F1H103Z	Ceramic	0.01μF	+80%, -20%	
Cs7	CM93D1H010D(Z)	Hi-Q	1pF	±0.5pF	
Cs8	CM93D1H070D(Z)	Hi-Q	7pF	±0.5pF	
Cs9, 10	CK45F1H103Z	Ceramic	0.01μF	+80%, -20%	
Cs11	CM93D1H020D(Z)	Hi-Q	2pF	±0.5pF	
Cs12, 13	CK45F1H103Z	Ceramic	0.01μF	+80%, -20%	
Cs14 ~ 16	CK45F1H203Z	Ceramic	0.02μF	+80%, -20%	
Cs17	CM93D1H180J(Z)	Hi-Q	18pF	±5%	
Cs18, 19	CQ92M1H393K	Mylar	0.039μF	±10%	
Cs20	CK45F1H103Z	Ceramic	0.01μF	+80%, -20%	
Cs21	CQ92M1H393K	Mylar	0.039μF	±10%	
Cs22, 23	CK45F1H203Z	Ceramic	0.02μF	+80%, -20%	
Cs24	CK45B1H102K	Ceramic	0.001μF	±10%	
Cs25	CK45F1H203Z	Ceramic	0.02μF	+80%, -20%	
Cs26	CM93D1H220J(Z)	Hi-Q	22pF	±5%	
Cs27	CM93D1H180J(Z)	Hi-Q	18pF	±5%	
Cs28	CK45F1H103Z	Ceramic	0.01μF	+80%, -20%	
Cs29	CM93D1H220J(Z)	Hi-Q	22pF	±5%	
Cs30 ~ 33	CK45F1H103Z	Ceramic	0.01μF	+80%, -20%	
Cs34	CM93D1H050D(Z)	Hi-Q	5pF	±0.5pF	
Cs35	CC45SL1HOR5C	Ceramic	0.5pF	±0.25pF	
Cs36	CM93D1H050D(Z)	Hi-Q	5pF	±0.5pF	
Cs37	CK45F1H103Z	Ceramic	0.01μF	+80%, -20%	
Cs38	CE04W1H3R3(RL)	Electrolytic	3.3μF	50WV	
Cs39	CM93D1H121J(Z)	Hi-Q	120pF	±5%	
Cs40	CK45B1H102K	Ceramic	0.001μF	±10%	
Cs41	CK45F1H103Z	Ceramic	0.01μF	+80%, -20%	
Cs42	CQ92M1H393K	Mylar	0.039μF	±10%	
Cs43	CE04W1H3R3(RL)	Electrolytic	3.3μF	50WV	
Cs44	CQ92M1H393K	Mylar	0.039μF	±10%	
Cs45	CQ92M1H473K	Mylar	0.047μF	±10%	
Cs46	CQ92M1H393K	Mylar	0.039μF	±10%	
Cs47	CE04W1H010(RL)	Electrolytic	1μF	50WV	
Cs48	CQ92M1H393K	Mylar	0.039μF	±10%	
Cs49	CE04W1E100(RL)	Electrolytic	10μF	25WV	
Cs50	CQ92M1H393K	Mylar	0.039μF	±10%	
Cs51	CQ92M1H223K	Mylar	0.022μF	±10%	
Cs52	CQ92M1H103K	Mylar	0.01μF	±10%	
Cs53	CQ92M1H223K	Mylar	0.022μF	±10%	
Cs54	CE04W1C470(RL)	Electrolytic	47μF	16WV	
Cs55, 56	CK45F1H103Z	Ceramic	0.01μF	+80%, -20%	
Cs57	CE04W1E100(RL)	Electrolytic	10μF	25WV	
Cs58	CK45F1H103Z	Ceramic	0.01μF	+80%, -20%	
Cs59	CE04W1C470(RL)	Electrolytic	47μF	16WV	
Cs60	CQ92M1H393K	Mylar	0.039μF	±10%	

Ref. No.	Parts No.	Description				Remarks
Cs61	CE04W0J470(RL)	Electrolytic	47 μ F	6.3WV		
Cs62, 63	CQ92M1H393K	Mylar	0.039 μ F	\pm 10%		
Cs64	CE04W0J470(RL)	Electrolytic	47 μ F	6.3WV		
Cs65	CE04W1H4R7(RL)	Electrolytic	4.7 μ F	50WV		
Cs66	CE04W1H3R3(RL)	Electrolytic	3.3 μ F	50WV		
Cs67	CE04W1H010(RL)	Electrolytic	1 μ F	50WV		
Cs68	CE04W1E100(RL)	Electrolytic	10 μ F	25WV		
Cs69	CE04W1H010(RL)	Electrolytic	1 μ F	50WV		
Cs70	CQ92M1H393K	Mylar	0.039 μ F	\pm 10%		
Cs71	CE04W0J470(RL)	Electrolytic	47 μ F	6.3WV		
Cs72	CK45B1H102K	Ceramic	0.001 μ F	\pm 10%		
Cs73	CE04W1E100(RL)	Electrolytic	10 μ F	25WV		
Cs74	CK45B1H731K	Ceramic	730pF	\pm 10%		
Cs75	CE04W1A470(RL)	Electrolytic	47 μ F	10WV		
Cs76	CE04W0J470(RL)	Electrolytic	47 μ F	6.3WV		
Cs77	CE04W1H010(RL)	Electrolytic	1 μ F	50WV		
Cs78	CQ92M1H223K	Mylar	0.022 μ F	\pm 10%		
Cs79	CE04W1E100(RL)	Electrolytic	10 μ F	25WV		
Cs80	CK45B1H731K	Ceramic	730pF	\pm 10%		
Cs81	CE04W1A101(RL)	Electrolytic	100 μ F	10WV		
Cs82	CQ92M1H473K	Mylar	0.047 μ F	\pm 10%		
Cs83	CK45B1H102K	Ceramic	0.001 μ F	\pm 10%		
Cs84 ~ 86	CK45F1H203Z	Ceramic	0.02 μ F	+80%, -20%		
Cs87	CC45SL1H101K	Ceramic	100pF	\pm 10%		
Cs88	CE04W1A470(RL)	Electrolytic	47 μ F	10WV		
Cs89	CE04W1H010(RL)	Electrolytic	1 μ F	50WV		
RESISTOR						
Rs1	PD14CY2E104J	Carbon	100k Ω	\pm 5%	1/4W	
Rs2	PD14CY2E101J	Carbon	100 Ω	\pm 5%	1/4W	
Rs3	PD14CY2E562J	Carbon	5.6k Ω	\pm 5%	1/4W	
Rs4	PD14CY2E101J	Carbon	100 Ω	\pm 5%	1/4W	
Rs5	PD14CY2E473J	Carbon	47k Ω	\pm 5%	1/4W	
Rs6	PD14CY2E562J	Carbon	5.6k Ω	\pm 5%	1/4W	
Rs7, 8	PD14CY2E102J	Carbon	1k Ω	\pm 5%	1/4W	
Rs9	PD14CY2E472J	Carbon	4.7k Ω	\pm 5%	1/4W	
Rs10	PD14CY2E333J	Carbon	33k Ω	\pm 5%	1/4W	
Rs11	PD14CY2E152J	Carbon	1.5k Ω	\pm 5%	1/4W	
Rs12	PD14CY2E102J	Carbon	1k Ω	\pm 5%	1/4W	
Rs13	PD14CY2E223J	Carbon	22k Ω	\pm 5%	1/4W	
Rs14	PD14CY2E472J	Carbon	4.7k Ω	\pm 5%	1/4W	
Rs15	PD14CY2E102J	Carbon	1k Ω	\pm 5%	1/4W	
Rs16	PD14CY2E152J	Carbon	1.5k Ω	\pm 5%	1/4W	
Rs17	PD14CY2E472J	Carbon	4.7k Ω	\pm 5%	1/4W	
Rs18	PD14CY2E333J	Carbon	33k Ω	\pm 5%	1/4W	
Rs19	PD14CY2E102J	Carbon	1k Ω	\pm 5%	1/4W	
Rs20	PD14CY2E332J	Carbon	3.3k Ω	\pm 5%	1/4W	
Rs21	PD14CY2E682J	Carbon	6.8k Ω	\pm 5%	1/4W	
Rs22	PD14CY2E223J	Carbon	22k Ω	\pm 5%	1/4W	
Rs23	PD14CY2E102J	Carbon	1k Ω	\pm 5%	1/4W	
Rs24	PD14CY2E101J	Carbon	100 Ω	\pm 5%	1/4W	
Rs25	PD14CY2E332J	Carbon	3.3k Ω	\pm 5%	1/4W	
Rs26	PD14CY2E153J	Carbon	15k Ω	\pm 5%	1/4W	

Ref. No.	Parts No.	Description				Remarks
Rs27	PD14CY2E561J	Carbon	560Ω	±5%	1/4W	
Rs28	PD14CY2E102J	Carbon	1kΩ	±5%	1/4W	
Rs29	PD14CY2E473J	Carbon	47kΩ	±5%	1/4W	
Rs30	PD14CY2E472J	Carbon	4.7kΩ	±5%	1/4W	
Rs31	PD14CY2E561J	Carbon	560Ω	±5%	1/4W	
Rs32	PD14CY2E102J	Carbon	1kΩ	±5%	1/4W	
Rs33	PD14CY2E562J	Carbon	5.6kΩ	±5%	1/4W	
Rs34	PD14CY2E153J	Carbon	15kΩ	±5%	1/4W	
Rs35	PD14CY2E222J	Carbon	2.2kΩ	±5%	1/4W	
Rs36	PD14CY2E102J	Carbon	1kΩ	±5%	1/4W	
Rs37	PD14CY2E221J	Carbon	220Ω	±5%	1/4W	
Rs38	PD14CY2E471J	Carbon	470Ω	±5%	1/4W	
Rs39, 40	PD14CY2E102J	Carbon	1kΩ	±5%	1/4W	
Rs41	PD14CY2E103J	Carbon	10kΩ	±5%	1/4W	
Rs42	PD14CY2E473J	Carbon	47kΩ	±5%	1/4W	
Rs44, 45	PD14CY2E471J	Carbon	470Ω	±5%	1/4W	
Rs46	RC05GF2H100J	Carbon	10Ω	±5%	1/2W	
Rs47	RN92A3D010K	Metal	1Ω	±5%	2W	
Rs48	PD14CY2E101J	Carbon	100Ω	±5%	1/4W	
Rs49	PD14CY2E222J	Carbon	2.2kΩ	±5%	1/4W	
Rs50	PD14CY2E472J	Carbon	4.7kΩ	±5%	1/4W	
Rs51	PD14CY2E223J	Carbon	22kΩ	±5%	1/4W	
Rs52	PD14CY2E102J	Carbon	1kΩ	±5%	1/4W	
Rs53, 54	PD14CY2E332J	Carbon	3.3kΩ	±5%	1/4W	
Rs55	PD14CY2E223J	Carbon	22kΩ	±5%	1/4W	
Rs56	PD14CY2E153J	Carbon	15kΩ	±5%	1/4W	
Rs57	PD14CY2E103J	Carbon	10kΩ	±5%	1/4W	
Rs58	PD14CY2E223J	Carbon	22kΩ	±5%	1/4W	
Rs59	PD14CY2E562J	Carbon	5.6kΩ	±5%	1/4W	
Rs60	PD14CY2E102J	Carbon	1kΩ	±5%	1/4W	
Rs61	PD14CY2E103J	Carbon	10kΩ	±5%	1/4W	
Rs62	PD14CY2E222J	Carbon	2.2kΩ	±5%	1/4W	
Rs63	PD14CY2E104J	Carbon	100kΩ	±5%	1/4W	
Rs64	PD14CY2E103J	Carbon	10kΩ	±5%	1/4W	
Rs65	PD14CY2E822J	Carbon	8.2kΩ	±5%	1/4W	
Rs66	PD14CY2E102J	Carbon	1kΩ	±5%	1/4W	
Rs67	PD14BY2E331J	Carbon	330Ω	±5%	1/4W	
SEMICONDUCTOR						
Qs1		2SK 19 (GR)				
Qs2		2SC388A				
Qs3, 4		2SC372				
Qs5 ~ 7		2SC460 (B)				
Qs8		2SC384 (Q)				
Qs9		3SC460 (B)				
Qs10		TA7061 AP				
Qs11		2SA496 (Y)				
Qs12		2SC496 (Y)				
Qs13 ~ 16		2SC733 (Y)				
Qs17		μPC-20C				
Ds1 ~ 4		1N60				
Ds6		SR1FM-2				
Ds7		1S1555				

Ref. No.	Parts No.	Description	Remarks
Ds8		WZ-090	
Ds9		1S1555	
Ds10, 11		1N60	
Ds12		1S1555	
Ds13		EQB01-17	
Ds14		1S1555	
COIL / TRANS			
Ls1	L34-0009-05	Antenna coil	
Ls2	L34-0010-05	RF coil (A)	
Ls3	L33-0086-05	Ferri-inductor	
Ls4	L34-0012-05	RF coil (C)	
Ls5, 6	L30-0005-05	IFT (10.7MHz)	
Ls7	L30-0199-05	IFT (455kHz)	
Ls8	L32-0002-05	Oscillator coil	
Ls9	L34-0014-05	Multiplier coil (B)	
Ls10	L34-0013-05	Multiplier coil (A)	
Ls11	L33-0086-05	Ferri-inductor	
Ls12	L30-0006-05	Disc coil (D) blue	
Ls13	L30-0007-05	Disc coil (E) black	
Ls14, 15	L33-0104-05	Ferri-inductor	
FILTER / CRYSTAL OSCILLATOR			
CFs1	L72-0015-05	Ceramic filter	
CFs2	L72-0025-05	Ceramic filter	
XLs1	L77-0327-05	Crystal oscillator (10.245MHz)	
POTENTIOMETER			
VRs1	R12-4016-05	PC trimmer 50k Ω	
VRs2	R12-3025-05	PC trimmer 10k Ω	
VRs3	R12-5014-05	PC trimmer 100k Ω	
MISCELLANEOUS			
-	J21-0707-04	PCB mounting hardware x 2	

■ PARTS LIST OF X56-1080-00 (TX UNIT)

Ref. No.	Parts No.	Description	Remarks
CAPACITOR			
Ct1	CM93D1H330J(Z)	Hi-Q 33pF $\pm 5\%$	
Ct2, 3	CM93D1H221J(Z)	Hi-Q 220pF $\pm 5\%$	
Ct4	CE04W1A470(RL)	Electrolytic 47 μ F 10WV	
Ct5	CK45F1H103Z	Ceramic 0.01 μ F +80%, -20%	
Ct6	CM93D1H220J(Z)	Hi-Q 22pF $\pm 5\%$	
Ct7	CK45F1H203Z	Ceramic 0.02 μ F +80%, -20%	
Ct8	CM93D1H330J(Z)	Hi-Q 33pF $\pm 5\%$	
Ct9, 10	CK45F1H203Z	Ceramic 0.02 μ F +80%, -20%	
Ct11	CM93D1H221J(Z)	Hi-Q 220pF $\pm 5\%$	
Ct12	CM93D1H101J(Z)	Hi-Q 100pF $\pm 5\%$	
Ct13	CQ92M1H223K	Mylar 0.022 μ F $\pm 10\%$	
Ct14	CM93D1H330J(Z)	Hi-Q 33pF $\pm 5\%$	
Ct15	CK45F1H203Z	Ceramic 0.02 μ F +80%, -20%	

Ref. No.	Parts No.	Description				Remarks
Ct16	CM93D1H221J(Z)	Hi-Q	220pF	±5%		
Ct17	CK45F1H103Z	Ceramic	0.01μF	+80%, -20%		
Ct18	CM93D1H390J(Z)	Hi-Q	39pF	±5%		
Ct19	CK45F1H103Z	Ceramic	0.01μF	+80%, -20%		
Ct20	CM93D1H050D(Z)	Hi-Q	5pF	±0.5pF		
Ct21	CM93D1H390J(Z)	Hi-Q	39pF	±5%		
Ct22	CM93D1H101J(Z)	Hi-Q	100pF	±5%		
Ct23	CK45E1H102P	Ceramic	0.001μF	±100%, -0%		
Ct24	CM93D1H180J(Z)	Hi-Q	18pF	±5%		
Ct25	CK45E1H102P	Ceramic	0.001μF	+100%, -0%		
Ct26	CM93D1H020D(Z)	Hi-Q	2pF	±0.5pF		
Ct27	CM93D1H120J(Z)	Hi-Q	12pF	±5%		
Ct28	CM93D1H101J(Z)	Hi-Q	100pF	±5%		
Ct29	CE04W1E100(RL)	Electrolytic	10μF	25WV		
Ct30, 31	CK45E1H102P	Ceramic	0.001μF	+100%, -0%		
Ct32	CM93D1H070D(Z)	Hi-Q	7pF	±0.5pF		
Ct33	CM93D1H100J(Z)	Hi-Q	10pF	±0.5pF		
Ct34	CM93D1H070D(Z)	Hi-Q	7pF	±0.5pF		
Ct35, 36	CM93D1H010D(Z)	Hi-Q	1pF	±0.5pF		
Ct37	CM93D1H330J(Z)	Hi-Q	33pF	±5%		
Ct38	CK45F1H103Z	Ceramic	0.01μF	+80%, -20%		
Ct39	CK45E1H102P	Ceramic	0.001μF	+100%, -0%		
Ct40	CQ92M1H104K	Mylar	0.1μF	±10%		
Ct41	CK45F1H103Z	Ceramic	0.01μF	+80%, -20%		
Ct42 ~ 45	CE04W1A470(RL)	Electrolytic	47μF	10WV		
Ct46	CQ92M1H103K	Mylar	0.01μF	±10%		
Ct47	CE04W1H010(RL)	Electrolytic	1μF	50WV		
Ct48, 49	CQ92M1H473K	Mylar	0.047μF	±10%		
Ct50	CE04W1H010(RL)	Electrolytic	1μF	50WV		
Ct51	CK45E1H102P	Ceramic	0.001μF	+100%, -0%		
Ct52	CK45F1H103Z	Ceramic	0.01μF	+80%, -20%		
Ct54	CK45F1H203Z	Ceramic	0.02μF	+80%, -20%		
Ct55	CM93D1H050D(Z)	Hi-Q	5pF	±0.5pF		
Ct56	CM93D1H180J(Z)	Hi-Q	18pF	±5%		
Ct57 ~ 59	CK45E1H102P	Ceramic	0.001μF	+100%, -0%		
Ct60	CK45F1H103Z	Ceramic	0.01μF	+80%, -20%		
Ct61 ~ 63	CK45E1H102P	Ceramic	0.001μF	+100%, -0%		
Ct64	CM93D1H100J(Z)	Hi-Q	10pF	±5%		
Ct65	CM93D1H150J(Z)	Hi-Q	15pF	±5%		
Ct66 ~ 77	CC45SL1H470J(Z)	Hi-Q	47pF	±5%		
Ct78	CK45E1H102P	Ceramic	0.001μF	+100%, -0%		
RESISTOR						
Rt1	PD14CY1E223J	Carbon	22kΩ	±5%	1/4W	
Rt2	PD14CY2E472J	Carbon	4.7kΩ	±5%	1/4W	
Rt3, 4	PD14CY2E102J	Carbon	1kΩ	±5%	1/4W	
Rt5	PD14CY2E223J	Carbon	22kΩ	±5%	1/4W	
Rt6	PD14CY2E472J	Carbon	4.7kΩ	±5%	1/4W	
Rt7	PD14CY2E681J	Carbon	680Ω	±5%	1/4W	
Rt8	PD14CY2E471J	Carbon	470Ω	±5%	1/4W	
Rt9 ~ 11	PD14CY2E470J	Carbon	47Ω	±5%	1/4W	
Rt12	PD14CY2E333J	Carbon	33kΩ	±5%	1/4W	
Rt13	PD14CY2E472J	Carbon	4.7kΩ	±5%	1/4W	

Ref. No.	Parts No.	Description	Remarks
Rt14, 15	PD14CY2E471J	Carbon 470Ω ±5% 1/4W	
Rt16	PD14CY2E223J	Carbon 22kΩ ±5% 1/4W	
Rt17	PD14CY2E472J	Carbon 4.7kΩ ±5% 1/4W	
Rt18	PD14CY2E820J	Carbon 82Ω ±5% 1/4W	
Rt19	PD14CY2E101J	Carbon 100Ω ±5% 1/4W	
Rt20	RC05GF2H101J	Carbon 100Ω ±5% 1/2W	
Rt21	PD14CY2E332J	Carbon 3.3kΩ ±5% 1/4W	
Rt22	PD14CY2E391J	Carbon 390Ω ±5% 1/4W	
Rt23, 24	PD14CY2E101J	Carbon 100Ω ±5% 1/4W	
Rt25	PD14CY2E472J	Carbon 4.7kΩ ±5% 1/4W	
Rt26	PD14CY2E221J	Carbon 220Ω ±5% 1/4W	
Rt27	PD14CY2E470J	Carbon 47Ω ±5% 1/4W	
Rt28	PD14CY2E101J	Carbon 100Ω ±5% 1/4W	
Rt29	PD14CY2E561J	Carbon 560Ω ±5% 1/4W	
Rt30	PD14CY2E102J	Carbon 1kΩ ±5% 1/4W	
Rt31	PD14CY2E682J	Carbon 6.8kΩ ±5% 1/4W	
Rt32	PD14CY2E103J	Carbon 10kΩ ±5% 1/4W	
Rt33	PD14CY2E104J	Carbon 100kΩ ±5% 1/4W	
Rt34	PD14CY2E473J	Carbon 47kΩ ±5% 1/4W	
Rt35	PD14CY2E222J	Carbon 2.2kΩ ±5% 1/4W	
Rt36	PD14CY2E151J	Carbon 150Ω ±5% 1/4W	
Rt37	PD14CY2E220J	Carbon 22Ω ±5% 1/4W	
Rt38	PD14CY2E681J	Carbon 680Ω ±5% 1/4W	
Rt39	PD14CY2E470J	Carbon 47Ω ±5% 1/4W	
Rt40	PD14CY2E561J	Carbon 560Ω ±5% 1/4W	
Rt41	RC05GF2H3R3J	Carbon 3.3Ω ±5% 1/2W	
SEMICONDUCTOR			
Qt1 ~3		2SC460 (B)	
Qt4		2SC535 (B)	
Qt5, 6		2SC388 (A)	
Qt7		TA7061 AP	
Qt8		2SC741	
Qt9		2SC1479	
Dt1		1S1658-1	
Dt2		WZ-090	
Dt3, 4		MI301	
Dt5		IN60	
COIL			
Lt1 ~3	L30-0141-05	Tuning coil 12MHz	
Lt4	L31-0175-05	Tuning coil 24MHz	
Lt5	L31-0176-05	Tuning coil 24MHz	
Lt6	L31-0263-05	Tuning coil 72MHz	
Lt7	L31-0178-05	Tuning coil 72MHz	
Lt8, 9	L31-0179-05	Tuning coil 144MHz	
Lt10	L31-0180-05	Tuning coil 144MHz	
Lt11	L33-0104-05	Ferri-inductor	
Lt12	L33-0127-05	Ferri-inductor	
Lt13	L33-0104-05	Ferri-inductor	
Lt14	L34-0386-05	VHF coil (C)	
Lt15	L34-0351-05	VHF coil (L)	
Lt16	L33-0089-05	Ferri-inductor	

Ref. No.	Parts No.	Description	Remarks
Lt17	L34-0386-05	VHF coil (C)	
Lt18	L34-0353-05	VHF coil (N)	
Lt19	L33-0089-05	Ferri-inductor	
Lt20	L34-0351-05	VHF coil (L)	
Lt21, 22	L34-0354-05	VHF coil (O)	
POTENTIOMETER			
VRt1, 2	R12-2015-05	PC trimmer 5k Ω (B)	
VRt3	R12-3025-05	PC trimmer 10k Ω (B)	
TRIMMER			
TCt1	C05-0009-15	Ceramic trimmer 6pF	
TCt2	C05-0015-15	Ceramic trimmer 40pF	
TCt3	C05-0010-15	Ceramic trimmer 10pF	
TCt4 ~ 15	C05-0030-15	Ceramic trimmer 20pF	
MISCELLANEOUS			
—	E18-2401-05	Crystal socket x 2	
—	F02-0023-05	Heat sink	
—	F11-0113-04	Shield case x 2	

PC BOARD

▼ POWER SUPPLY (X43-1080-00)

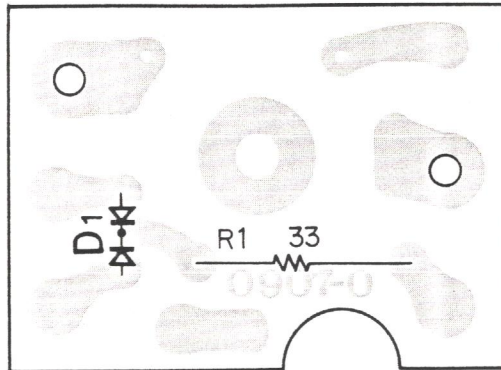

D1:DS-17

▼ TONE (X52-1030-01)

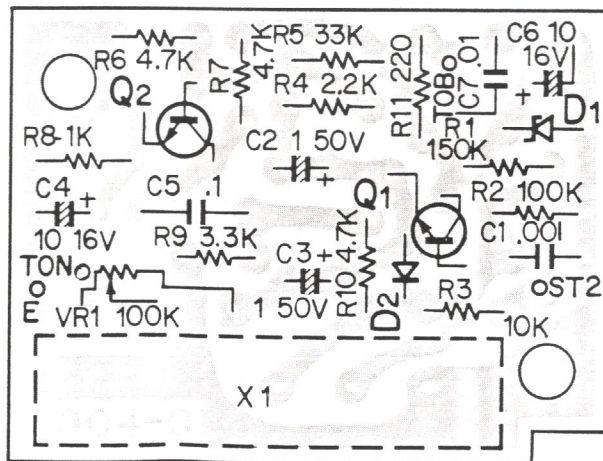

Q1,2:2SC458(B),D1:WZ-090
D2:1S1555

▼ RX (X55-1030-61)

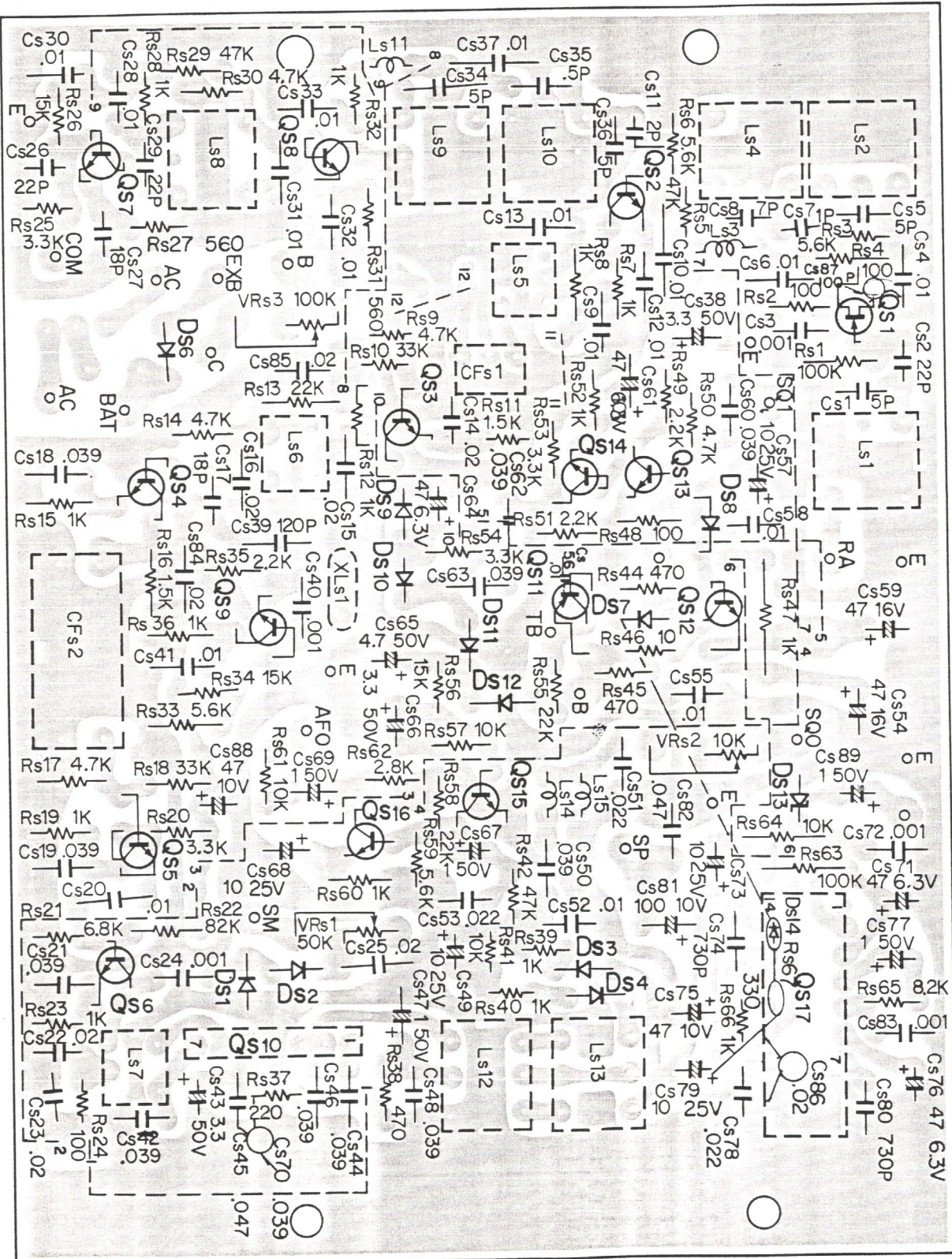

Qs1: 2SK19(GR) Qs2: 2SC388A Qs3,4: 2SC372 Qs5-7,9: 2SC460(B) Qs8: 2SC384(O) Qs10: TA7061AP
 Qs11: 2SA496(Y) Qs12: 2SC496(Y) Qs13-16: 2SC733(Y) Qs17: μ PC-20C Ds1-4,10,11: 1N60 Ds6: SR1FM-2
 Ds7,9,12,14: 1S1555 Ds8: WZ-090 Ds13: EQB01-17

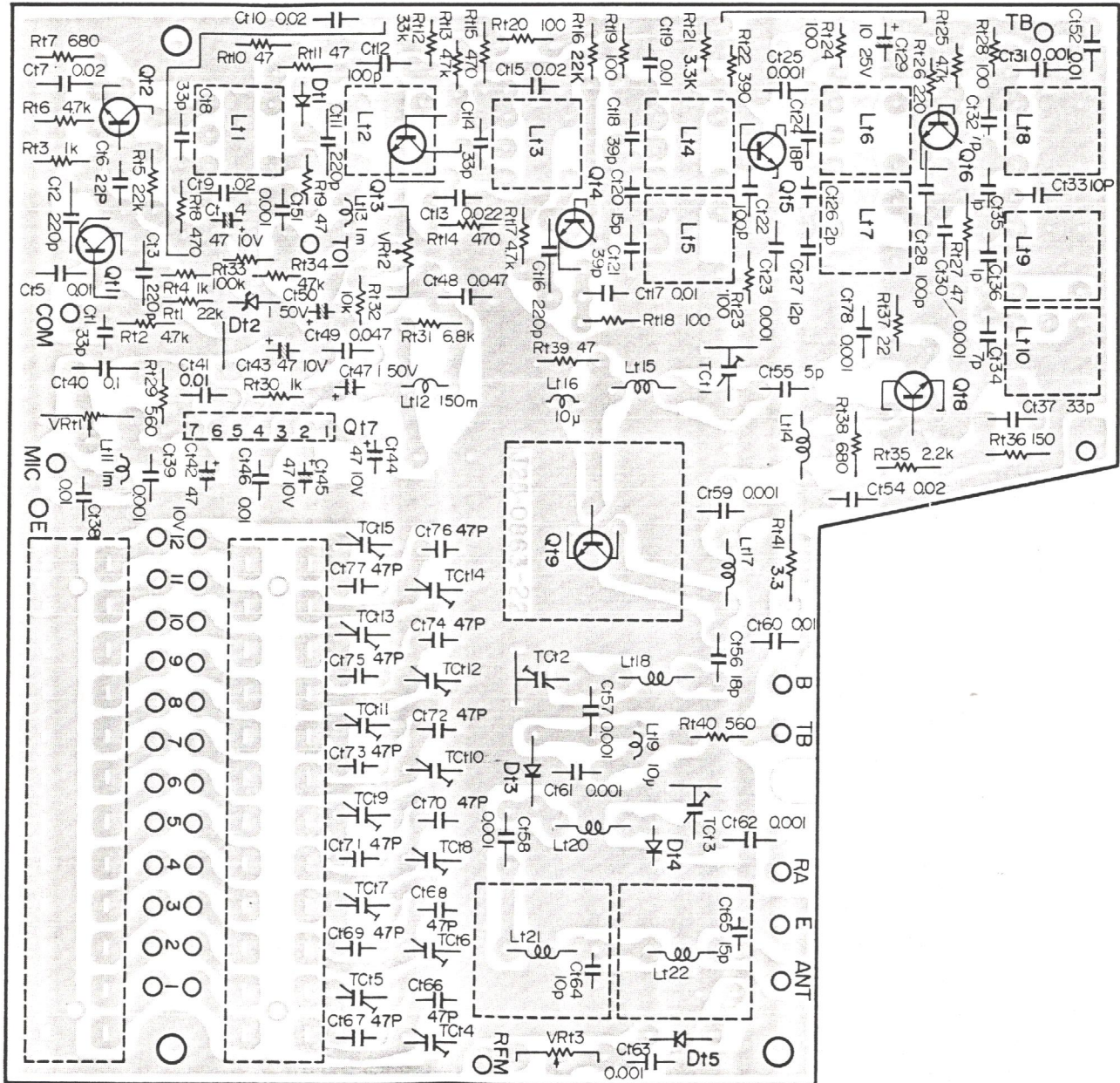

Dt1: 1S1658-1 Dt2: WZ-090 Dt3,4: M1301 Dt5: 1N60 Qt1-3: 2SC460(B) Qt4: 2SC535(B) Qt5,6: 2SC388A
 Qt7: TA7061AP Qt8: 2SC741 Qt9: 2SC1479

BLOCK DIAGRAM

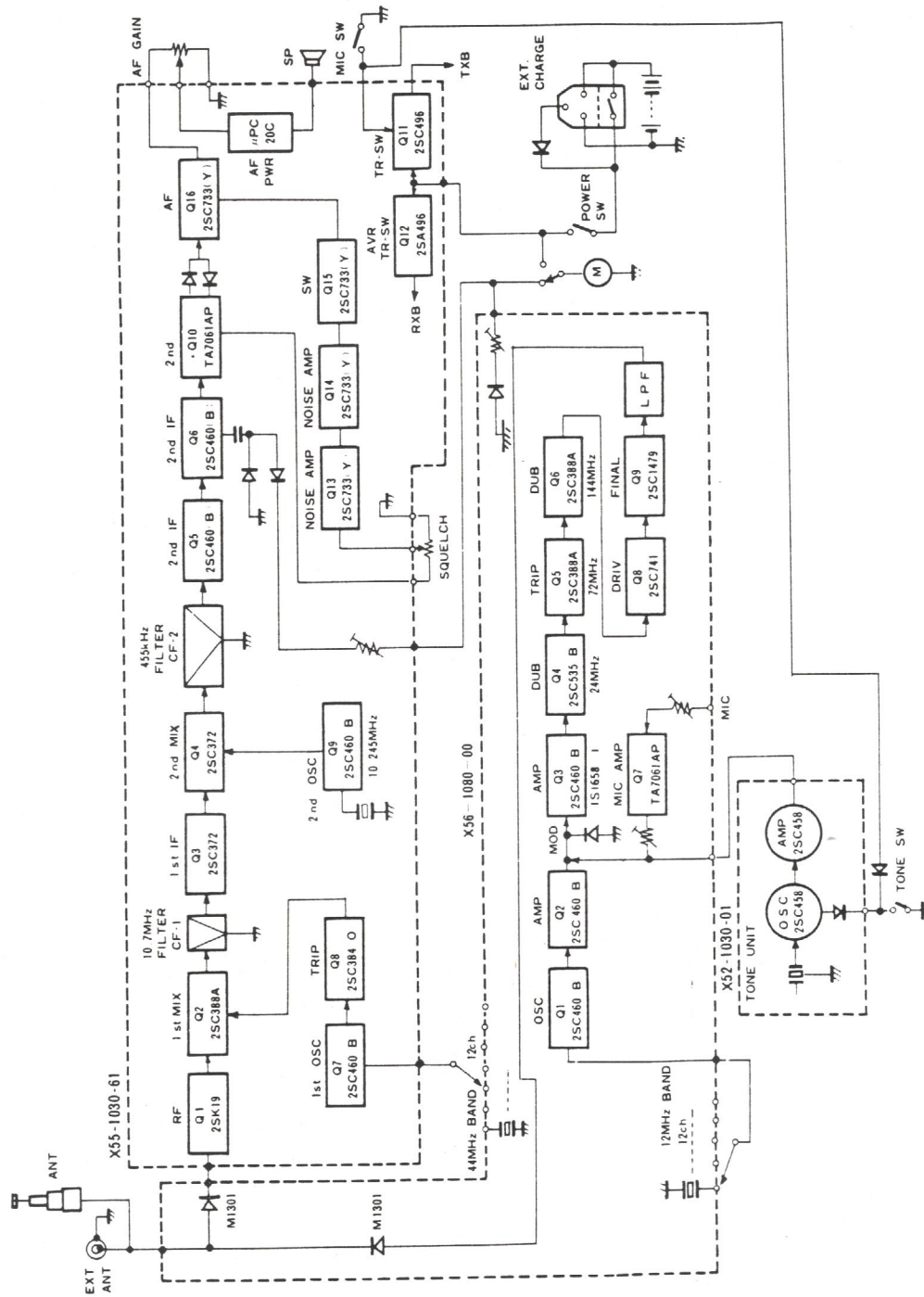

SCHEMATIC DIAGRAM

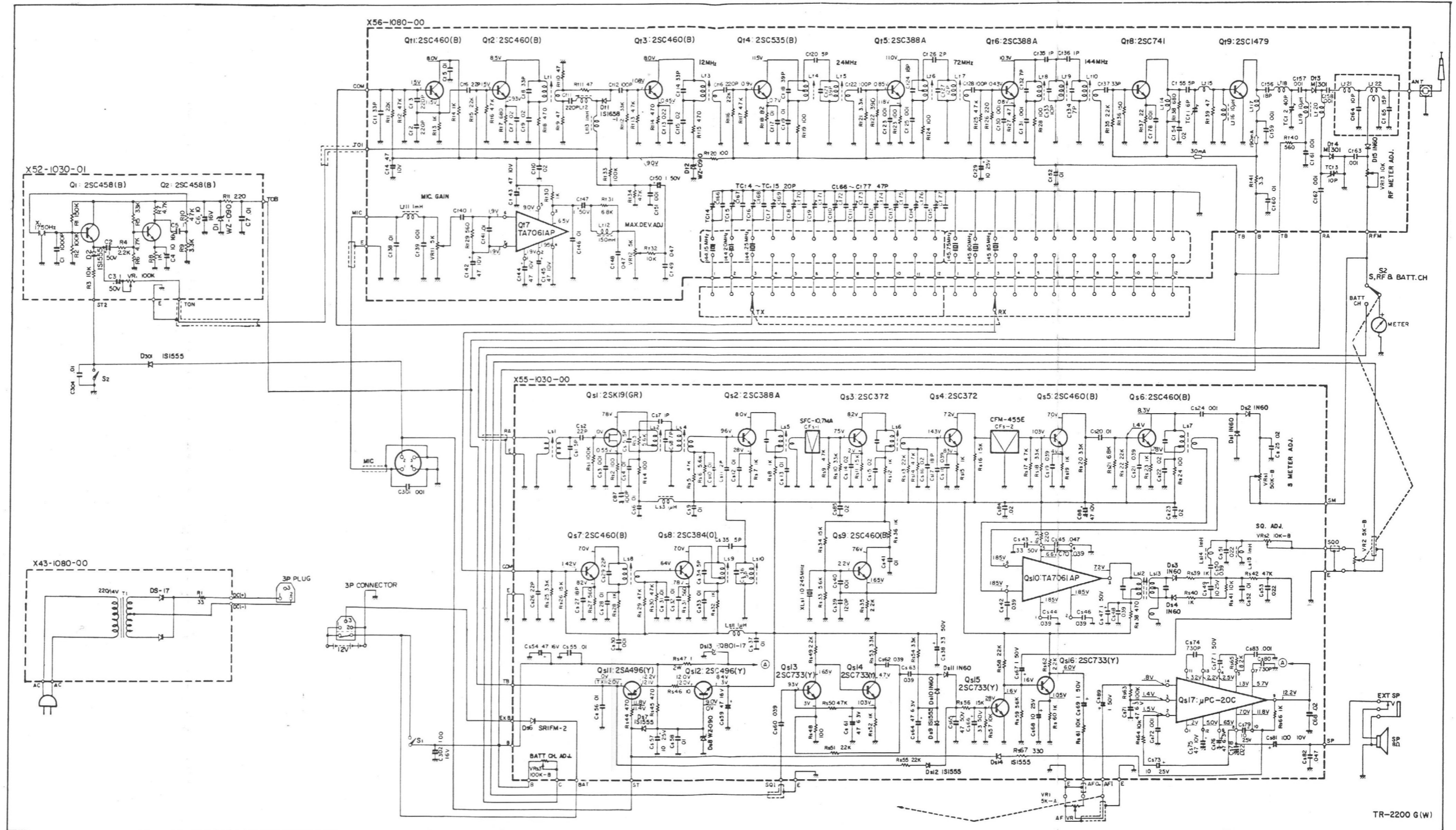

TR-2200 G(W)

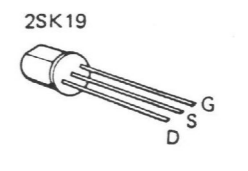
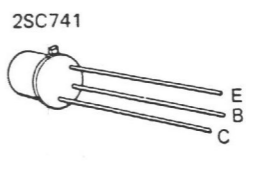
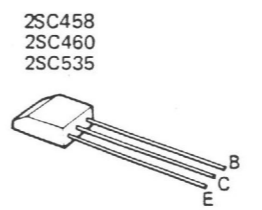
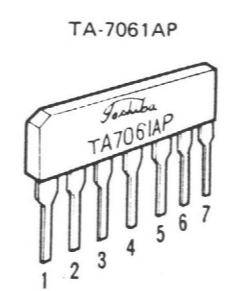
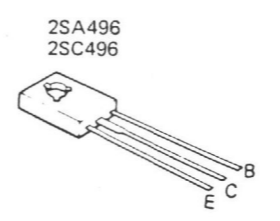
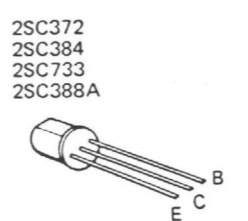
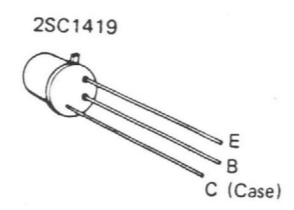
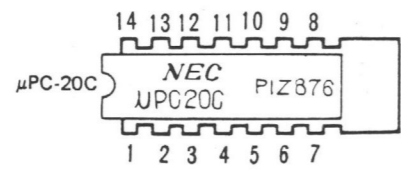

SPECIFICATIONS

GENERAL

SOLID-STATE COMPONENTS

TRANSISTORS	24
FET	1
ICs	3
DIODES	22

POWER SUPPLY

EXTERNAL	10.4V ~ 15.2V (standard 13V DC)
GROUND	Negative ground

POWER CONSUMPTION

TRANSMISSION	Approximately 420 mA at 13.0V
RECEPTION	Approximately 55 mA at 13.0V

DIMENSIONS

135mm W x 58mm H x 191mm D

WEIGHT

1.8 kg (including 10 nickel-cadmium cells and microphone)

TRANSMIT SECTION

FREQUENCY	12 channels in 144 to 146 MHz
TYPE OF EMISSION	F3
RF OUTPUT POWER	1.0 watts at 13V DC
MODULATION	Variable reactance phase shift
MAX. FREQ. DEVIATION	± 7.5 kHz
MULTIPLICATION	12 times
FUNDAMENTAL FREQ.	12 MHz band
SPURIOUS RADIATION	Less than 1m watts
ANTENNA IMPEDANCE	50 Ω
MICROPHONE	Dynamic type with PTT switch, 500 Ω

RECEIVE SECTION

FREQUENCY	12 channels in 144 to 146 MHz
TYPE OF EMISSION	F3
CIRCUITRY	Double superheterodyne system
SENSITIVITY	Less than 1 μ V for 20 dB S/N
PASS-BAND WIDTH	More than 16 kHz at 6 dB down
SELECTIVITY	Less than 32 kHz at 50 dB down
FILTER	Ceramic filter
INTERMEDIATE FREQ.	1st IF 10.7 MHz 2nd IF 455 kHz
AUDIO OUTPUT	More than 0.5 watts (10% distortion)
AUDIO OUTPUT (MAX.)	More than 0.7 watts

Note: Circuits and ratings are subjected to modification due to technical improvement.



Manufactured by TRIO ELECTRONICS, INC., Tokyo, Japan