

= Lafayette HE. 10

INSTRUCTIONS
FOR
GLOBE-TROTTER MODEL 9R-4J
COMMUNICATIONS RECEIVER

SOLD BY

DISTRIBUTED BY

N. V. HANDEL MAATSCHAPPIJ
v/h F. A. P. JENNEN

HERENGRACHT 286, AMSTERDAM

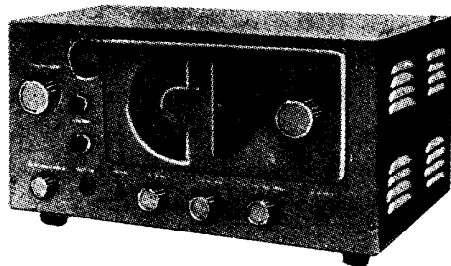

COMMUNICATIONS RECEIVER MODEL 9R-4J

SPECIFICATIONS

Frequency Ranges :	A : 550-1600Kc B : 1.6-4.8Mc C : 4.8-14.5Mc D : 11-30Mc
I.F. :	455Kc
Sensitivity :	13 μ V (S/N 20 db input at 10Mc)
Selectivity :	-60db (at 1Mc \pm 10Kc)
Output Power :	1.5W
Power Consumption :	50VA 50c/s or 60c/s
Tubes :	6BD6 RF 6BE6 Mixer 6BE6 Osc. 6BD6 \times 2 IF 6AV6 Detect. Low Freq. 6AV6 ANL, BFO 6AR5 Output GT 5Y3 Rectifier
Dimensions :	(7-7/8" H \times 15" W \times 9" D)
Weight :	19.3 lbs.

I. GENERAL DESCRIPTION :

You have just purchased the finest high quality communications receiver. The 9R-4J combines the necessary features to provide an economical, attractive, easily-constructed unit. It is well suited for the amateur, shortwave listener or fishing vessels. Its size readily adapts itself to any location.

This set covers the broadcast band from 550-1600 K.C., plus three short wave bands covering 1.6-30 M.C. The BANDSPREAD tuning, with the large logging scale makes short wave tuning a cinch. Other controls include the MAIN TUNING; ON-OFF VOLUME ON-OFF A.N.L.; B.F.O. M.V.C. and A.V.C.; BAND-CHANGE SW.; I.F. GAIN; STANDBY-RX Sw.; and a ZERO SET for the S METER; and BFO PITCH. A headphone jack is also

provided on the front panel.

The 9R-4J employs 9 tubes. It features a 6BD6 r.f. amp.; a 6BE6 1st mixer; a 6BE6 local osc.; two stages of i.f. amplification with 6BD6; a 6AV6 second det., A.V.C. and audio amp.; a 6AR5 output; and 5Y3 full wave rectifier. In addition, there's a 6AV6 which doubles an automatic noise limiter (ANL) and a B.F.O.

All the necessary components are supplied with the kit, excepting an output transformer and a speaker. The receiver was designed for operation with a PM speaker. However, with a slight circuit modification an electro dynamic speaker may be used. The output power of this set is such that it'll drive a 4-8" PM speaker quite efficiently.

II. ASSEMBLY & WIRING

All components are already mounted, with the exception of the condensers and resistors shown in the List of Components Supplied for Assembly of 9R-4J Kit.

Perform the wiring in the following sequence—power supply, filament leads, ground bus, plate supply leads, audio circuits, second detector circuit, ANL circuit, i.f. stages, mixer stage, local oscillator, and r.f. amplifier stage. Twist all a.c. power and filament runs to eliminate hum pick-up. Pictorial diagrams 2, 4, and 5 cover this. Refer to Fig. 1 for a complete schematic. The grounding lugs cut out in the chassis for the r.f. grounds should be polished and tinned before making any connections. Ground the braid of the five shielded audio lines. The BFO coupling capacitor consists of a gimmick (2 or 3 turns of insulated wire) having a capacity of approximately 1 MMF.

After completing the wiring, mount all the capacitors and resistors. A little time spent in the study of the pictorial diagrams will save much time in soldering and unsoldering connections. Fasten all the components and wires in their respective places, then solder. Recheck the wiring carefully. When satisfied that all is in order, insert the tubes in the correct sockets by following the tube number indicated at each socket. Connect the speaker to the receiver by using the 5 prong socket provided. Plug it into the receptacle at the back of the receiver. NOTE that whenever this plug is removed, the primary line to the power transformer is broken. If desirous to use an electrodynamic speaker, having a 1500 OHM field, the filter resistor may be eliminated by substitution. The B voltage supply should be increased to 360V by changing to the correct lugs on the power transformer. Apply power. The tubes should light and signals will be heard on the various bands. If no trouble is encountered, lace the shielded audio lines.

III. ALIGNMENT:

For best results a calibrated r.f. oscillator should be used for setting up this receiver. However, if this cannot be done, local stations can be used as check points—just follow the same general alignment procedure.

(a) I.F. ALIGNMENT

Set the s.g. at 455 KC and modulate it with either 400 or 1000 C.P.S. Inject this signal

between PIN 7 of the mixer tube (6BE6) and ground. REMOVE THE LOCAL OSCILLATOR TUBE. Connect an a.c. voltmeter between the plate (PIN 3) of the 6AR5 tube and ground. The plate terminal should be connected through a 1 MF capacitor. Switch the BFO, MVC, AVC switch to the MVC position and leave it there for the remainder of the alignment operation. This position will give a sharper indication on the output meter. Increase the output from the s.g. to get a good reading. Check that the I.F. GAIN control is fully clockwise. Turn the VOLUME control up as well. Don't overload the stages with too strong a signal. Adjust the cores of the i.f. transformers for a peak reading on the meter. Thereafter don't turn these screws unless the proper equipment is on hand.

(b) R.F. ALIGNMENT

Leave the output meter connected as for the i.f. alignment. Replace the local oscillator tube, set the BANDSPREAD pointer on O. Short A₂ and E terminals at the rear of the receiver. Connect the s.g. between A and E through a 400 OHM dummy load. Follow the steps as noted in R.F. ALIGNMENT CHART below :

R.F. ALIGNMENT CHART

Band	Step	Dial & S.G. Setting	Adjust Local Oscillator	Adjust Mixer & RF. Stages	Note
A	1	600 KC	Padder		Repeat 1 & 2 until dial calibration is correct at both ends Adjust for maximum reading.
	2	1400 KC	Trimmer		
	3	1400 KC		Trimmer	
B	4	1.8 MC	Iron Core		Repeat 4 & 5, similar to 1 & 2
	5	4.0 MC	Trimmer		
	6	1.8 MC		Iron Core	Repeat 6 & 7 until both ends track
	7	4.0 MC		Trimmer	
C	8	6.0 MC	Iron Core		Repeat 8 & 9, similar to 1 & 2
	9	12.0 MC	Trimmer		
	10	6.0 MC		Iron Core	Repeat 10 & 11, similar to 6 and 7
	11	12.0 MC		Trimmer	
D	12	13.0 MC	Iron Core		Repeat 12 & 13, similar to 1 & 2
	13	26.0 MC	Trimmer		
	14	13.0 MC		Iron Core	Repeat 14 & 15, similar to 6 & 7
	15	26.0 MC		Trimmer	

(C) B. F. O.

Disconnect the s.g. from A₁. Tune the receiver to about 900 KC until a strong signal is picked up. Set the BFO, MVC, AVC switch to BFO. Adjust the slug of the BFO coil until a BEAT is heard at 910 KC (This is the 2nd harmonic of the BFO). Connect an antenna to the receiver. Note the beat point. If it's absent, rotate the slug still further, until the note comes in. Adjust pitch by slightly varying the BANDSPREAD DIAL.

(d) S METER ADJ

The S Meter will indicate ONLY when the BFO, MVC, AVC switch is in the AVC position. The meter is calibrated to indicate S9 with an input of 100 microvolts at 7.0 MC. S8 and S7 are calibrated downwards in 6 DB steps. The S9 setting may be varied, to suit individual requirements, by changing the value of R 3 (1500 OHM, 1/2 W resistor, which is connected between PINS 2 & 7 of the 6BD6, r.f. amplifier and the meter). After the set has warmed up adjust the ZERO ADJ, with no signal tuned in. Finally, changing the IF GAIN control will affect the S METER.

IV. THE ANTENNA

A good antenna is essential for optimum performance of this communications receiver. A doublet will give excellent results on amateur bands. The doublet connects between A₁ and A₂. An inverted L or zep type makes a good all-wave antenna. When using the latter, short A₂ and E. Then connect the antenna to A₁. Both types are illustrated in the following diagram :

- A. 1/4 wave doublet—1 ft. space between middle insulators. 1 ft. to start of lead in twist. Ant. 30-50 ft. high.
- B. Inverted L or zep. 30-50 ft. long 25 ft. high

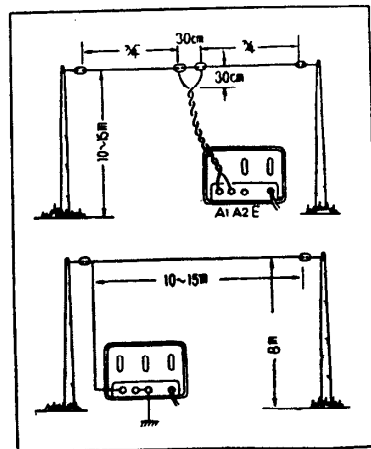

**LIST OF COMPONENTS SUPPLIED
FOR ASSEMBLY OF 9R-4J KIT**

1 ea.	Resistor,	20K	1/4W	13 ea.	Ceramic Condenser	.01 uF
1 ea.	"	100K	"	3 ea.	Mica Condenser, ± 10%	100 PF
1 ea.	"	500K	"	2 ea.	" " " "	250 PF
2 ea.	"	1M	"	1 ea.	Electrolytic Condenser, 50V x 10	uF
1 ea.	"	2M	"	1 ea.	Tubular Condenser	.05 uF
1 ea.	"	5M	"	1 ea.	" "	.005uF
3 ea.	"	300Ω	1/2W			
5 ea.	"	1K	"			
1 ea.	"	1.5K	"	80"	AC cord with plug	
1 ea.	"	15K	"	80"	Speaker cord	
1 ea.	"	50K	"	20"	Single conductor shielded wire	
1 ea.	"	250K	"	30 ft.	Plastic covered wire	
1 ea.	"	500Ω	1W	20"	Bare wire	
1 ea.	"	2K	10W		Bolt/nut/washer	

ADDITIONAL PARTS REQUIRED

3 ea.	Tube	6BD6	1 ea.	4-8" PM Speaker
2 ea.	"	6BE6	1 ea.	Output transformer to match
2 ea.	"	6AV6		6AR5 tube and speaker
1 ea.	"	6AR5		
1 ea.	"	5Y3 GT		

REMARKS: ALL OTHER PARTS HAVE ALREADY BEEN MOUNTED and/or WIRED.

FIG. 1

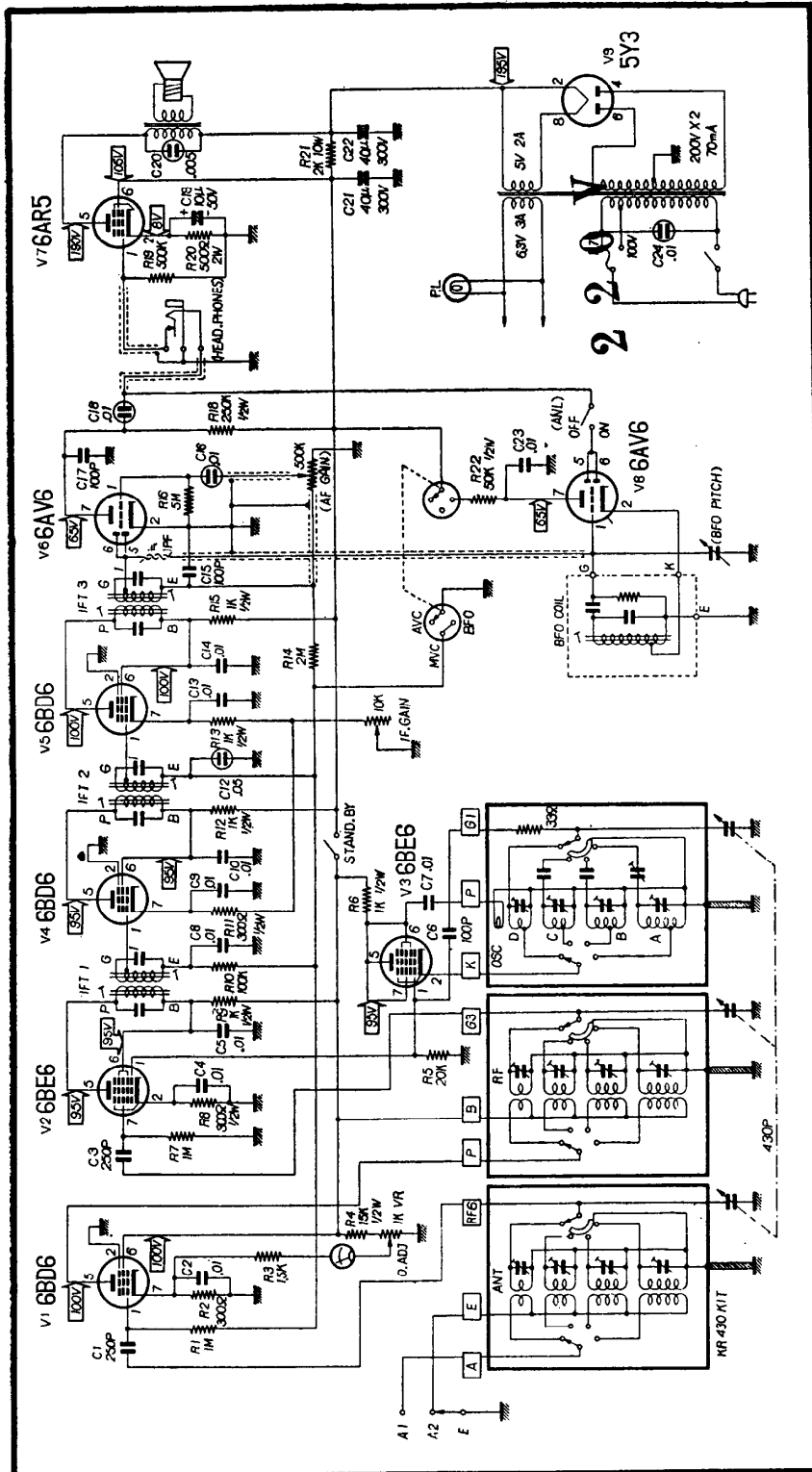

FIG. 2

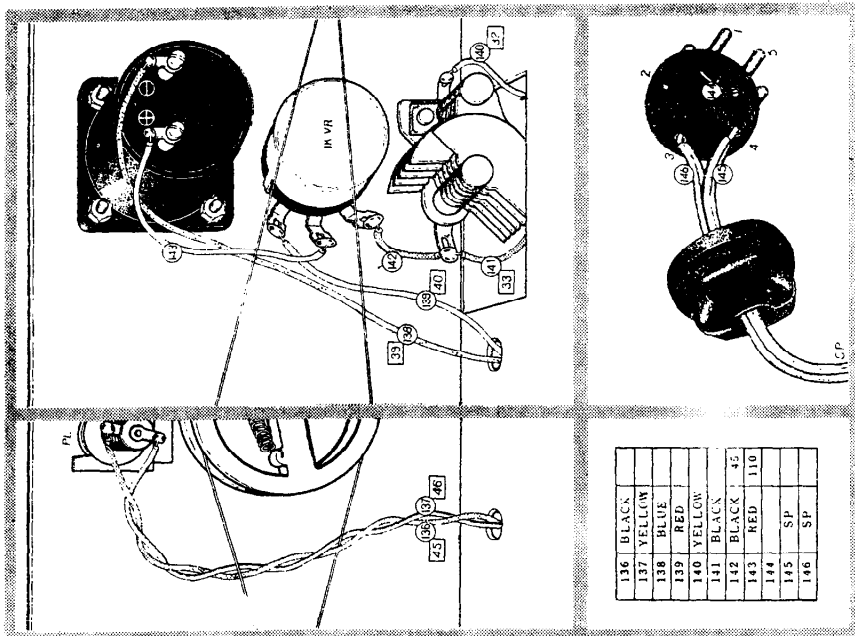

FIG. 3

