

**This obsolete manual file is provided as a courtesy to you by Ten-Tec, Inc.**

**Ten-Tec's service department can repair and service virtually everything we have built going back to our first transceivers in the late 1960's. It is our ability to continue offering service on these rigs that has led to their re-sale value remaining high and has made a major contribution to our legendary service reputation.**

**Printed and bound copies of all manuals are available for purchase through our service department if you would prefer not to use this copy as your transceiver manual.**

**We can repair or service your Ten-Tec equipment at our facility in Sevierville, TN. We also offer support via telephone for all products via during usual business hours of 8 a.m. to 5 p.m. USA Eastern time, Monday through Friday. We have a large supply of parts for obsolete products. Repairing a transceiver or amplifier yourself? Contact us for parts pricing information.**

**Service department direct line: (865) 428-0364  
Ten-Tec office line: (865) 453-7172  
Service department email: [service@tentec.com](mailto:service@tentec.com)  
Address: 1185 Dolly Parton Parkway, Sevierville, TN 37862 USA**

**We have found it is most effective for us to help you troubleshoot or repair equipment with a consultation via telephone rather than by email.**

**Suggested contact methods are:**

**Troubleshooting or repairing equipment – call (865) 428-0364  
Other inquiries – call (865) 428-0364 or email [service@tentec.com](mailto:service@tentec.com)**

**THANK YOU AND 73 FROM ALL OF US AT TEN-TEC**

**TEN-TEC**

**OPERATOR'S  
MANUAL**

**CORSAIR II**

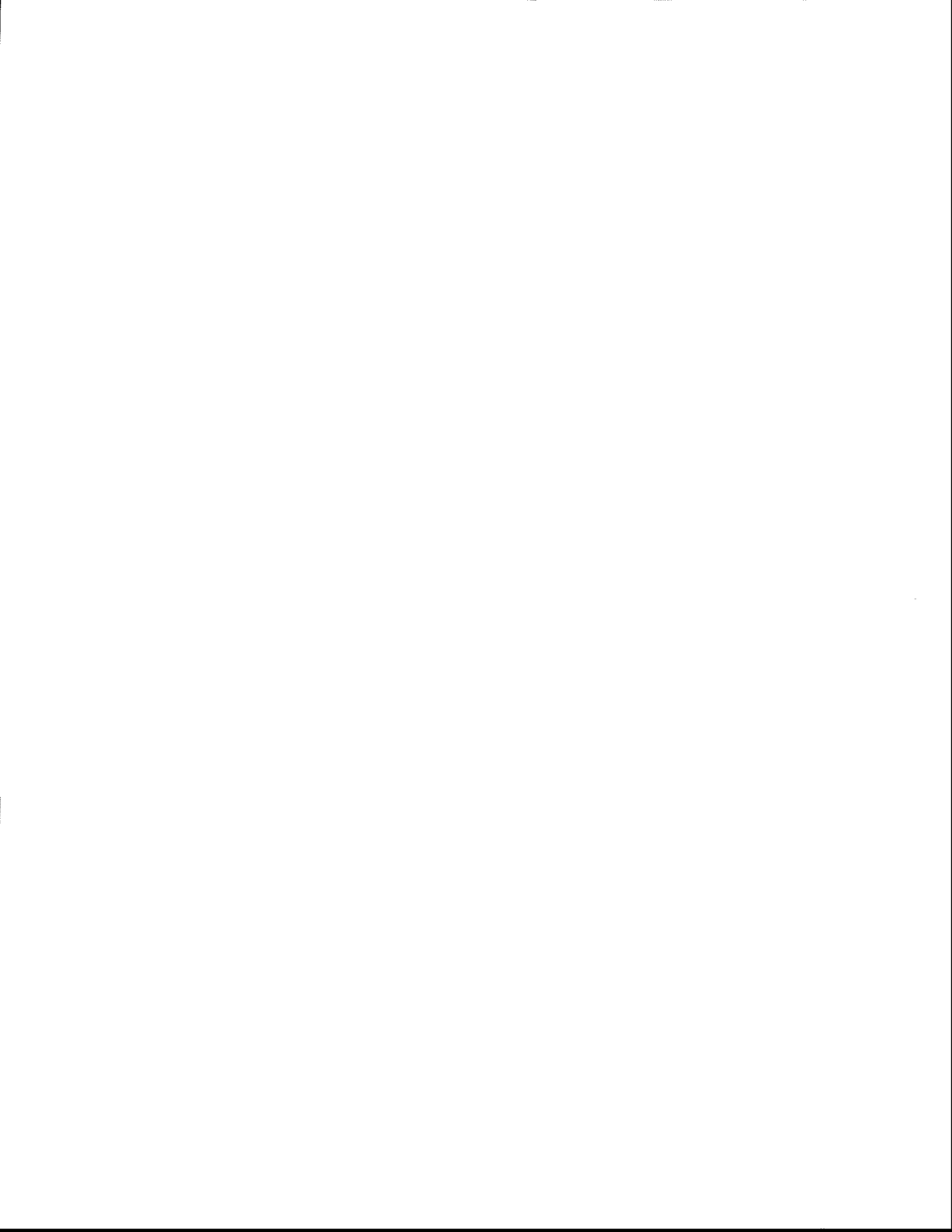

# CONTENTS

SECTION		PAGE
I	INTRODUCTION	1- 1
	CONDENSED OPERATING INSTRUCTIONS	1- 1
	SPECIFICATIONS	1- 3
II	DETAILED OPERATING INSTRUCTIONS	2- 1
	Rear Panel Connections	2- 1
	Front Panel Controls	2- 5
	Operating Hints	2-11
	An Important Message	2-13
III	ALIGNMENT AND SERVICE	3- 1
	Internal Adjustments	3- 1
	Disassembly	3- 2
	Signal Block Diagram	Fold-Out
	Main Chassis Wiring	Fold-Out
	SEMICONDUCTOR IDENTIFICATIONS	3- 5
	PTD 81038	3- 5
	OSCILLATOR MIXER 80975	3- 7
	RF MIXER 80987	3- 9
	XTAL FILTER 81253	3-11
	NOISE BLANKER 80977	3-12
	PBT, PASS BAND TUNING 80979	3-14
	IF-AF 80984	3-15
	VOX BOARD 81249	3-18
	AUDIO PROCESSOR 81255	3-19
	DOUBLE SIDEBAND GENERATOR 80980	3-21
	LOW LEVEL DRIVER 81037	3-23
	FINAL AMPLIFIER 80565	3-24
	BANDPASS FILTER 80976	3-26



LOWPASS FILTER 80969	3-27
SWR BOARD 80970	3-27
DIGITAL READDOUT	3-29
CONTROL BOARD 80978	3-31
MODE SWITCH 81256	3-33
LED DISPLAY 80983	3-33
DISPLAY BOARD 81248	3-33
DISPLAY DRIVER 81247	3-33
PARTS LISTS	3-34

## SECTION I

### INTRODUCTION

Carefully remove your Model 561 CORSAIR II from the packing carton and examine it for signs of shipping damage. Should any shipping damage be apparent, notify the delivering carrier or dealer immediately, stating the full extent of the damage. It is recommended that you keep the shipping cartons. In the event that storage, moving, or reshipment becomes necessary, they come in handy. An accessory packet, warranty card and manual are packed with the CORSAIR II. Make sure that you have not overlooked anything.

The CORSAIR II is a medium power transceiver employing the latest techniques in solid state technology. It features digital frequency readout which inherently contains a crystal oscillator for accuracy.

As shipped from the factory, the CORSAIR II contains all necessary crystals for transceiver operation in the 160, 80, 40, 30, 20, 17, 15, 12 and 10 meter bands.

The CORSAIR II is extremely versatile. Although essentially a fixed station, it is equally at home when used mobile or portable. It operates from 12-14 volts dc or from 115/230 volts ac with an external power supply.

As you become familiar with the operation of your CORSAIR II, you will value the built-in operating conveniences more and more. Broad band circuitry eliminates tuneup. The normal sideband is selected, whether it be upper or lower, according to the band in use. Indicator light emitting diodes (LEDs) are provided for various functions. These are just a few of the many features you will enjoy. All in all, the CORSAIR II is designed for active, serious amateurs.

### CONDENSED OPERATING INSTRUCTIONS

The following instructions will enable the operator to quickly place the CORSAIR II into operation. For a more detailed description of the controls and their functions, refer to SECTION II.

#### FRONT PANEL CONNECTIONS

MIC - For ssb operation, plug a dynamic, ceramic, crystal or electret microphone, such as the TEN-TEC Model 214 or 700-C, into this jack. Amplified microphones can be used if the output level is adjusted to a low enough value to prevent the microphone channel from overloading.

#### REAR PANEL CONNECTIONS

POWER - Use a 12 to 14 V dc power source capable of delivering 18 amperes, well regulated. When powering from the TEN-TEC Model 260 power supply, interconnect units with the cable attached to the supply.

When other supplies or a battery are used, pin connections to the power socket are:

- Pin 1, bottom - Negative 12-14 volts (GND)
- Pins 2 & 3 - Power Switch
- Pin 4, Top - Positive 12-14 volts.

Power switch contacts, Pins 2 and 3, should not be used to switch the high current dc directly, due to switch contact ratings and voltage drop across the switch. If it is desired to switch power on and off from the front of the transceiver, use these pins to switch the primary ac voltage in cases where an ac power pack is used, or to actuate an intermediate relay such as the Guardian 200 Series or Potter Brumfield PR3DY0, either of which have sufficient current handling contact ratings in 12-14 V dc installations.

For minimum cable loss, use number 12 or 14 gauge wire for the plus and minus leads. Smaller gauge wire can be used for the switch leads.

When operating the CORSAIR II fixed, portable, or mobile with an external power supply or any source other than a TEN-TEC power supply, the protective circuitry for the final amplifier, being in the ac power supplies, is not present. In order to protect the final amplifier, it is necessary to limit any over-current that may be caused by excessive drive or improper antenna matching. This may be accomplished by inserting Model 1140 Circuit Breaker in series with the twelve volt supply line. The circuit breaker will also function as an external on/off switch.

ANTENNA - Connect a 50 ohm, unbalanced resonant antenna, such as a beam, dipole, or vertical. Balanced antennas and those with higher impedances should be matched with an antenna tuner such as the Model 229A Antenna Tuner.

RECEIVE-TRANSCIVEIVE SWITCH - For normal transceiver operation, position this switch in the TRANSCEIVE position. If an external amplifier or a separate receiving antenna is to be used, refer to the detailed instructions in SECTION II. (Use a small probe to actuate switch. Raised bezel prevents accidental throwing of switch.)

KEY - For cw operation, connect a straight key, bug, or electronic keyer to this jack. When using other electronic keyers, they should be configured for positive keying - not "grid block" or negative.

## FRONT PANEL CONTROLS

### INITIAL RECEIVER CONTROL SETTINGS

- 1.) Select desired band and frequency.
- 2.) Rotate RF control fully clockwise and push knob in.
- 3.) Advance AF control to suitable audio level.
- 4.) Rotate NOTCH control fully clockwise.
- 5.) Set XTAL switch to position 3.

- 6.) Set MODE switch to CW or SB-N.

#### INITIAL TRANSMITTER CONTROL SETTINGS

- 1.) Select desired band or band segment with band switch.
- 2.) Tune dial to frequency of operation.
- 3.) Set ALC control fully clockwise.
- 4.) Push POWER switch, located on AF GAIN control, in.
- 5.) Rotate MODE switch to LOCK position.
- 6.) Rotate DRIVE control until ALC light glows.
- 7.) Observe SWR reading on meter. For efficient operation, SWR should be less than 2 to 1. If it isn't, make alteration to antenna system to reduce SWR.
- 8.) Switch MODE switch to desired mode -- SB-N or CW. In SB-N, select either VOX or PTT switch position. For cw operation, the setting of the DRIVE control in the LOCK mode, step 6 above, is correct setting. In ssb, DRIVE control setting should be readjusted so that the ALC indicator just lights on voice peaks.

#### CORSAIR II SPECIFICATIONS

##### GENERAL

FREQUENCY COVERAGE: 1.8-2.3, 3.5-4.0, 7.0-7.5, 10.0-10.5, 14.0-14.5, 18.0-18.5, 21.0-21.5, 24.5-25.0, 28.0-30.0 MHz transceive. (VFO provides approximately 40 kHz overrun on each band edge.)

VFO STABILITY: Less than 15 Hz change per degree averaged over a 40 degree change from 70 to 110 degrees F after 30 minutes warmup. Less than 10 Hz change 105 to 125 V ac line voltage when using a TEN-TEC power supply.

TUNING RATE: Vernier, 18 kHz per revolution, typical.

READOUT: 6 digit, 0.3" LED numerals.

ACCURACY:  $\pm$  100 Hz.

SEMI-CONDUCTORS: 1 LSI, 25 IC's, 94 transistors, 109 diodes, 6 LED readouts.

PC BOARDS: 22 PC assemblies with plug-in cables.

CONSTRUCTION: Rigid steel chassis. Extruded aluminum front panel with two-tone gray inserts. Textured gray top and bottom, snap-up stainless steel bail.

POWER REQUIRED: 12-14 V dc., 850 mA receive, 18.5 A max transmit.

DIMENSIONS: HWD 5-1/4" x 15" x 14" (13 x 38 x 36 cm), bail retracted.

NET WEIGHT: 14 lbs. (6.4 kg).

## RECEIVER

SENSITIVITY: 0.25  $\mu$ V for 10 dB S+N/N, all bands. 0.8  $\mu$ V typical with RF amplifier off.

SELECTIVITY: 16-pole crystal ladder filtering. 2.4 kHz bandwidth, 1.6 to 1 shape factor at 6/60 dB. Three position switch selects standard ssb filter, optional 1.8 kHz ssb filter, 500 Hz cw filter, or 250 Hz cw filter.

NOTCH FILTER: Greater than 50 dB notch tunable between 200 Hz and 3.5 kHz.

AUDIO BANDPASS FILTER: 8 pole active band pass centered at 750 Hz. Variable fader control selects filtered or flat audio response.

CW SPOT: Removes offset and shifts BFO 750 Hz.

I-F FREQUENCIES: 9 MHz and 6.3 MHz.

PASS BAND TUNING (FBT): Shifts 2nd I-F frequency  $\pm$  1.5 kHz.

ANTENNA INPUT: Low impedance unbalanced.

RX ANTENNA INPUT: Switchable 50 Ohm RCA phono jack provides separate input to receiver section only.

AUDIO OUTPUT: 1 watt @ 8 ohms with less than 2% distortion. Built-in speaker.

SPURIOUS RESPONSES: All below equivalent 10 dB S+N/N signal except 1.838 MHz (less than 15 dB S+N/N), 21.300 MHz (less than 20 dB S+N/N), and 28.980 MHz (which can be eliminated by using low end of 29.0-29.5 MHz band segment).

NOISE BLANKER: Switchable on/off with adjustable threshold and blanking width.

I-F REJECTION: Greater than 60 dB.

S-METER: Automatically switched on when receiving. Calibrated to 50  $\mu$ V at S9,  $\pm$  3 dB.

DYNAMIC RANGE: 95 dB, typical.

OFFSET TUNING: Dual range, MAX  $\pm$  4 kHz; MIN  $\pm$  1.5 kHz, typical.

RECEIVER RECOVERY DELAY: Less than 30 ms from key-up.

## TRANSMITTER

DC POWER INPUT: Maximum 200 watts @ 14 V dc cw and ssb. 100% duty cycle for up to 20 minutes.

RF POWER OUTPUT: 85-100 watts, typical.

OUTPUT IMPEDANCE: 50 ohms, unbalanced.

MICROPHONE INPUT: High impedance. Accepts high or low impedance microphones with 5 mV output. Polarizing voltage available for electrets.

T/R SWITCHING: VOX or PTT on ssb. Instant break-in or semi-break-in on cw.

CW SIDETONE: Internally generated. Adjustable tone and volume independent of af gain control. Operates only in cw mode.

PROGRAMMABLE IAMBIC KEYER: 8-50 wpm with 40 character memory.

SSB GENERATION: 9 MHz, 8-pole crystal ladder filter. Balanced modulator.

CARRIER SUPPRESSION: 60 dB typical.

UNWANTED SIDEBAND SUPPRESSION: 60 dB typical at 1.5 kHz tone.

SPURIOUS OUTPUT: Better than -45 dB relative to full output.

METER: Forward power, collector current, SWR, audio processing level. Selectable 4 position switch.

CW OFFSET: 750 Hz, automatic.

ALC CONTROL: Front panel adjustable. 30 to 100 watts output, LED indicator.

## FRONT PANEL CONNECTIONS AND CONTROLS

BP FILTER; PBT; OFFSET; NOTCH; AF GAIN/POWER; RF GAIN/ATTN; DRIVE; Bandswitch; Main Tuning Knob; MODE; METER Switch; KEYER SPEED; N.B. LEVEL; N.B. WIDTH; ALC threshold; PROCESS level; QSK/VOX switch; AGC switch; XTAL switch; OFFSET SELECT switches (2); SPOT push-button; PHONES; MIC.

## REAR PANEL CONNECTIONS AND CONTROLS

High speed QSK output jack (open collector); EXT.T/R jack (relay closure); SPARE jack (uncommitted RCA phono); AUX. 12 VDC jacks (2); KEYER MEM. jack for controlling keyer memory; KEY jack; PTT jack; VFO IN jack; VFO OUT jack; AUDIO IN jack; AUDIO OUT jack; ACCESSORIES socket; GND terminal; EXT. SPKR jack; KEYER PADDLE jack; POWER socket; 50 OHM ANTENNA connector (SO-239); RX ANTENNA jack (RCA phone); RX-TRX switch for separate receive antenna; DELAY, GAIN, ANTI-VOX CONTROLS.

SECTION II  
DETAILED OPERATING  
INSTRUCTIONS

REAR PANEL CONNECTIONS

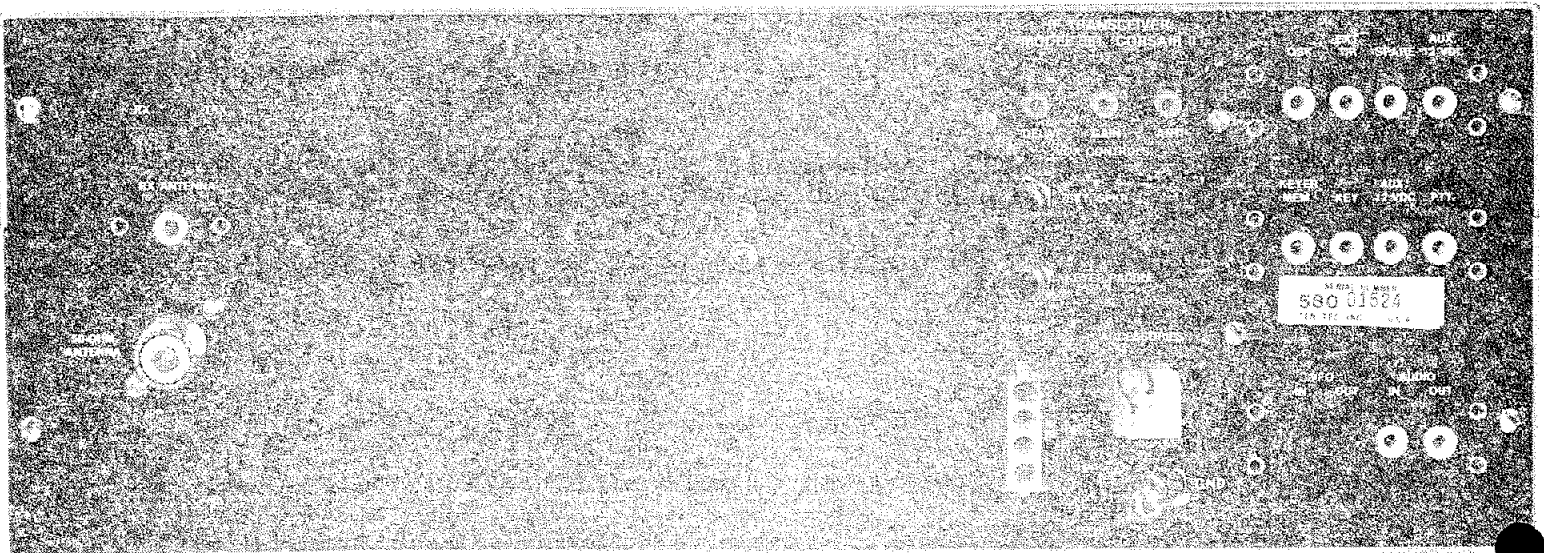

POWER SOCKET

A supply of 12 to 14 V dc capable of supplying 18 amperes, negative ground, is required. The CORSAIR II may be operated in mobile installations having 12 volt negative ground systems or powered from an ac supply, such as TEN-TEC Model 260.

For battery operation, as well as operation with any power source other than a TEN-TEC power supply, it is recommended that a cable of at least 12 gauge conductors be run directly from the battery or power source to the transceiver through a circuit breaker of sufficient rating, such as Model 1140. DO NOT depend on a fuse for protection since its reaction time is too slow.

For fixed station installation, cable length from the power supply should be as short as possible and made from 12 gauge wire or larger. The chassis should be strapped to a good earth ground system as should all other equipment, both as a personal hazard precaution and for optimum performance.

A power switch is located on the AF GAIN/POWER control and is wired only to Pins 2 and 3 of the four pin power socket on the rear apron. The switch is not in series with the power input leads. The switch need not be used for ac operation if on-off switching is desired at the power supply location. Or, the switch may be connected in series with the

115/230 volt primary lead to the supply if switching function is desired from the front panel. In this case, the power supply switch should permanently be positioned in the "on" position. The Model 260 power supply which is designed for use with the CORSAIR II already has provisions for this mode of switching.

For dc operation, the contact rating of the switch on the AF GAIN/POWER control is NOT sufficiently high to carry the 18 amperes required. Switch contact resistance will result in an appreciable voltage drop across the switch. The insertion of Model 1140 circuit breaker in series with the 12 V dc supply line will protect the final amplifier from over-current conditions and provide an external on-off switch.

Pin connections for the power socket are: Pin 1, bottom of rig = GND; Pins 2 and 3 = ON-OFF switch; Pin 4 = 12-14 V dc. Pin 1 has a rib on the plastic part of the cable connector and Pin 4 has a rib on the chassis connector.

The +12 volt line is internally fused with a 20 ampere fast-blo fuse, and a high power diode is connected across the line to ground in a normally reverse-biased polarity. Under these circumstances, the diode does not conduct. If reverse polarity is applied, the diode conducts heavily and blows the fuse, thereby protecting the transistors and electrolytic capacitors.

#### GROUND STRAP

To reduce the possibility of stray rf pickup on interconnecting cables which may cause parasitic oscillations, all station equipment should be well grounded to earth. It is also important to strap all equipment chassis together with short, heavy leads, preferably with braid. The strap between the power supply and the transceiver also serves to reduce voltage drop on the negative 12 volt lead caused by resistance in the wire and connector contacts. In mobile installations, connect a ground strap between the rear panel ground lug and the automobile chassis.

#### ANTENNA

Any antenna presenting 50 to 75 ohms impedance will load satisfactorily. Random length antennas and open wire feed systems will require a matching system. Most popular mobile antennas will operate at their resonant frequency without special matching. When they are used as portable antennas, a good ground system or counterpoise should be provided. The CORSAIR II is designed for use with an unbalanced feed system. Coaxial shield is connected to the shell and the center conductor to the pin of the PL-259 connector.

#### EXT I/R

This jack is intended to actuate a high power linear amplifier. It is derived from a set of normally open contacts on the auxiliary relay located on the Control Board. One side of this switch is also at ground potential and therefore should not be used to switch the 115/230 volt line. When operating cw, a drop-out delay is incorporated in the relay circuit and is adjustable with a thumb potentiometer located on the CONTROL BOARD. When operating ssb, this drop-out delay is switched out of



the circuit. Since this relay does not control any of the internal functions of the transceiver, delay is factory set to an average value when shipped. It should be adjusted for suitable delay only when external equipment is controlled by this relay.

**CAUTION:** There are two potentiometers located on the CONTROL BOARD. It is very important that the setting of the offset adjust potentiometer not be disturbed. Improper setting of this control may possibly result in out-of-band operation. Refer to the CONTROL BOARD description in Section III for the location of these controls.

#### QSK

This is an open collector output switched by the internally generated transmit (T) signal. This output will sink 100 mA max with 0.6 V voltage drop. Circuit details appear on the CONTROL BOARD schematic.

#### KEY

The transmitter can be keyed by a ground connection to the high impedance KEY input when the CW mode is selected. This line is compatible with open collector (positive) keyer outputs as well as bugs and straight keys. When the key is closed the antenna is electronically disconnected from the receiver and receiver stages are disabled. A cw sidetone is generated and can be adjusted for the desired pitch and volume with thumbwheel potentiometers accessible through a hole in the bottom panel. In the FAST QSK setting receiver recovery time is less than 30 mS, suitable for AMTOR communications.

#### KEYER\_PADDLE

This 1/4" stereo jack operates the built-in Iambic keyer. A tip to ground connection sends dits and ring to ground sends dahs. Keyer speed is controlled from the front panel.

#### KEYER\_MEM.

The KEYER MEM. line is a dual function input to the programmable keyer. If this input is grounded the keyer enters the program mode and waits for the first paddle closure. No memory is used until the first character is sent. Once a message is started however the memory will record the transmission exactly, including pauses. Approximately 40 characters can be programmed. If the KEYER MEM. input is grounded through a 33k/10 uf parallel combination a pulse is generated which signals the keyer to send its programmed message. The memory is clocked at the rate selected by the front panel KEYER SPEED control.

#### AUX\_12\_VDC

Either of these jacks may be used to power external equipment such as an electronic keyer or external VFO. The Model KR19 Keyer Paddle and Model 263B External VFO are two such items available as accessories to the CORSAIR II.

Each of these jacks is connected to the +12 V dc line after the protective fuse and is rated at a maximum of 2 amperes. If an ac power supply is employed, its current capacity must be great enough to supply the transceiver requirements plus that of any equipment powered through

either or both of the AUX 12 V dc jacks.

#### ACCESSORIES\_SOCKET

A nine pin female chassis-mounted MOLEX connector is available for interfacing an external VFO or other peripheral equipment with the CORSAIR II. Refer to main chassis schematic diagram for pin identifications. As shipped from the factory, a jumper is plugged into this socket which connects the PTO enable to the + regulated line. This jumper is necessary for proper operation unless the Model 2636 External VFO is being used.

#### AUDIO\_IN

Low level (500 mV max) RTTY or phone patch signals can be summed into the mic channel through this input.

#### AUDIO\_OUT

Low impedance audio output is available from this jack for RTTY or phone patch. Signal level can be set by the AF GAIN/POWER control and is available regardless of external speaker or headphone connections. Output equals 2.0 vrms maximum.

#### RECEIVE\_ANTENNA

This jack provides a connection directly to the receiver front end when the rear panel RX-TRX switch is in the RX position. This also allows for the use of a secondary receiver when the switch is placed in the TRX position and the secondary receiver antenna input is connected to the jack.

#### VFO\_IN-OUT

These jacks provide means to switch the internal PTO signal on and off when using Model 2636 Remote VFO accessory. As shipped from the factory, these two jacks are connected externally with a U shaped jumper pin.

#### PTT

This jack is in parallel with the push-to-talk line on the microphone jack. It may be used as an external transmit/receive station switch and is operable only in the ssb mode.

#### EXTERNAL\_SPEAKER

Phone jack, for connecting external speaker. Using this jack disconnects the internal speaker.

#### SPARE

Uncommitted RCA phono jack.

#### VOX\_CONTROLS

The rear panel GAIN, DELAY and ANTI VOX controls can be adjusted to

suit the individual operator's needs. To adjust proceed as follows:

- 1) Adjust the AF GAIN to a comfortable level.
- 2) While speaking into the mic at normal level, adjust the GAIN for reliable VOX action.
- 3) Adjust the DELAY so that T/R switching does not occur between words when speaking into the microphone.
- 4) Set the ANTI VOX to the point where receiver audio will not trip the VOX circuit at moderate volumes.

### FRONT PANEL CONTROLS

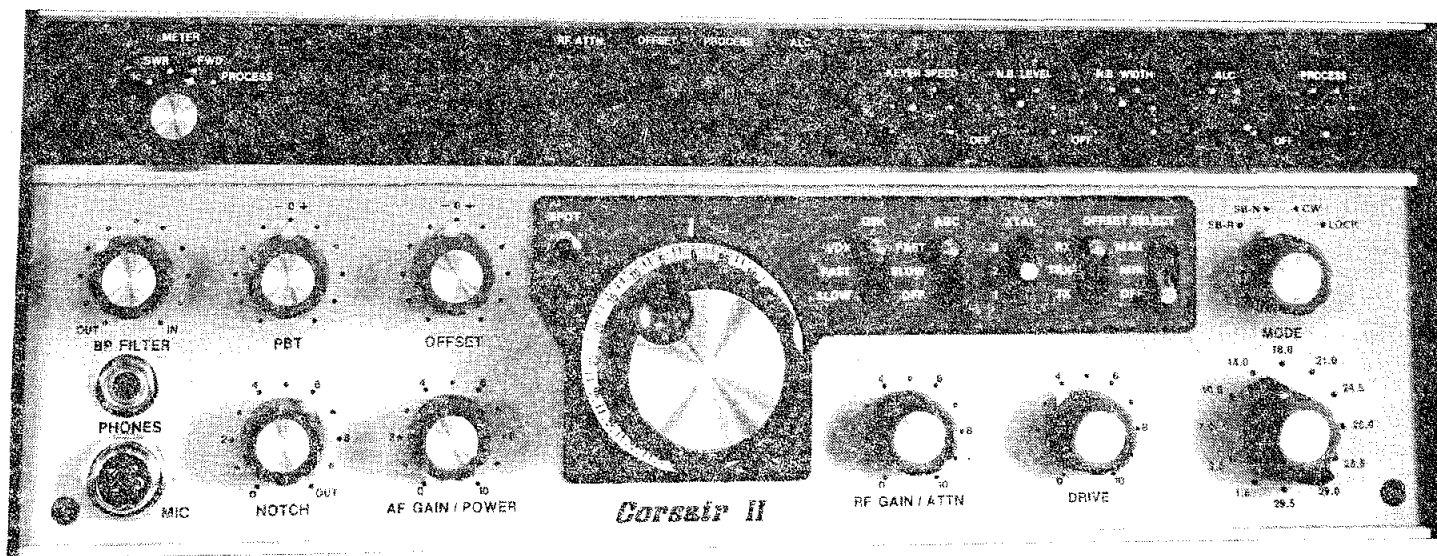

#### AF GAIN/POWER

The AF GAIN/POWER control varies the speaker or headphone volume and sets the signal level at the rear panel AUDIO OUT jack. The push-pull switch shorts pins 2 and 3 on the four pin power connector when pushed in.

#### RF GAIN/ATTN

The RF GAIN/ATTN control varies the bias to the i-f amplifier stages. It is used to reduce susceptibility to overload in the presence of extremely strong signals. The AGC is dependent on the setting of this control and therefore the S meter is calibrated only when the RF GAIN is fully clockwise. The push-pull switch on this control inserts an attenuator pad in place of the low-noise receiver pre-amp stage. The

# More than just a radio.



Ten-Tec is more than just a manufacturer of Amateur Radio equipment. Our legendary service department repairs almost everything we've ever built. Customer support representatives are active hams that can provide the advice you need to obtain the right equipment and set up your station the way it should be. No one in the industry matches our risk-free trial period for new equipment. When you buy Ten-Tec, you get our entire company in the box with your new radio. Ask a friend who owns "us". Proudly MADE IN USA!

**1185 Dolly Parton Pkwy., Sevierville, TN 37862 Sales: 800-833-7373**

We accept Visa, MC, American Express and Discover. Office (865) 453-7172. FAX (865) 428-4483.  
Sales: Mon-Fri 8:00-5:30 (Eastern Time), [sales@tentec.com](mailto:sales@tentec.com). Service: Mon-Fri 8:00-5:00 (Eastern Time),  
[service@tentec.com](mailto:service@tentec.com), (865) 428-0364. Shipping is additional. TN residents add 9.5% sales tax

**[www.tentec.com](http://www.tentec.com)**

effect is a 20 dB reduction in signal to the rf mixer but with more dynamic range and greater sensitivity than would be the case with a simple 20 dB rf attenuator. A front panel RF ATTN LED indicates that the attenuator is selected.

#### METER\_SWITCH

In receive mode, the meter will automatically read S units when the METER switch is in any position except IC. When transmitting the meter indicates the following:

IC position measures the current drawn by the final amplifier module. Use the scale marked 0 to 20 amperes.

SWR position provides a reading of power reflected from the antenna. When the forward power is 100 watts, the SWR can be read from the scale marked SWR.

FWD position measures forward power to the antenna. In this position, a peak reading circuit is automatically selected so PEP output can be measured in the ssb mode. Use the FWD scale marked 0 to 100 watts.

PROCESS position displays the level of compression applied to the MIC input when the PROCESS control is turned ON.

#### MODE\_SWITCH

The SB-N setting of this switch is used for ssb transmissions on the normal side of the carrier frequency. It will provide lower sideband signals on 160, 80, 40, 30 and 17 meters, and upper sideband on 20, 15, 12 and 10 meters. This is accomplished by using either the sum or the difference frequencies in the mixer. The opposite or reverse sideband can be selected by rotating the MODE switch to the SB-R position. In the ssb modes, the transmitter can only be energized by shorting the PTT line to chassis. The cw key line is disconnected.

In the CW position, the sidetone signal is fed to the audio system. Its level and pitch can be adjusted with the two adjacent thumb potentiometers, accessible through the large hole in the bottom plate.

In cw, the transmitted frequency is automatically offset 750 Hz from the receiver setting. This compensates for the 750 Hz beat note of the received signal and puts the transmitter exactly on the received frequency. This 750 Hz frequency was selected as the offset to correlate with the center frequency of the cw filter.

The transmitter can be switched on only by shorting the KEY jack to chassis in the cw mode. PTT lines in the MIC jack and the external PTT jack are disconnected.

The LOCK position of the MODE switch is used for system checks and SWR measurements. It energizes the transmitter on the cw frequency but does not key the sidetone oscillator.

#### BAND\_SWITCH

The band switch selects the amateur bands of 1.8, 3.5, 7.0, 10.0, 14.0, 18.0, 21.0, 24.5 and 28.0 to 30.0 MHz. With approximately 600 kHz range per band. The marine band in the 1.8 to 2.3 MHz range is covered.

### MAIN TUNING

In the Model 561, megahertz, kilohertz, and hundreds of hertz are displayed on the six digit LED display. Hundreds of hertz are in green to easily separate the fraction of kHz from the rest of the reading. When using Model 2636 Remote VFO, the display will read the frequency in use at the time. The counter can be accurately set to WWV as outlined in SECTION III. The main tuning knob skirt has 1 kHz markings to facilitate quick, relatively small excursions, such as used when QSYing to avoid QRM, or when passing traffic in net operation. (Up or down 5 to 10 kHz is easily accomplished without having to read the digital display.)

### PASSBAND TUNING

The PBT control adjusts the position of the second i-f crystal filter in relation to the fixed first i-f filter. When the filter selected by the XTAL switch is wide, i.e. 2.4 or 1.8 kHz, the PBT control essentially becomes a variable bandwidth control. CCW rotation reduces the bandwidth toward the low side, CW rotation reduces the bandwidth toward the high side. This is a great advantage on ssb since it permits adjusting the passband to reject adjacent channel interference on either side. When a narrower filter is selected, i.e. 500 or 250 Hz, the PBT control is used in the normal passband tuning sense.

Our PBT circuit produces the effect of varying the BFO, changing the pitch of signals passing through the narrow filter to separate signals which are very close together. On RTTY, it can place the narrow filter to pass only the 2295 and 2125 Hz tones for superior rejection of adjacent signals. The PBT control has no effect on the transmitter frequency or bandwidth.

### OFFSET TUNING

The OFFSET control allows independent control of the receive or transmit frequency, through two selectable excursion ranges, as determined by the position of the OFFSET SELECT switches. Clockwise rotation from the center position increases the frequency, counterclockwise rotation decreases the frequency.

Offset tuning is advantageous when several stations are being worked in a roundtable and all are not exactly on the same frequency. The received stations can be "zeroed in" with the OFFSET control without upsetting your transmit frequency. This is termed RECEIVE offset tuning and is engaged by placing the OFFSET SELECT switch in the RX position. Transmit offset is useful when a station calling CQ says "listening 2 kHz up". Without changing the VFO, select RX offset, tune OFFSET control 2 kHz higher then select TX offset. The original frequency will be returned and the transmit frequency will be 2 kHz higher than that indicated during receive. Transceiver offset, TRX on the OFFSET SELECT switch, permits excursions away from a set frequency. For instance, moving away from a net frequency for traffic to a specific station.

The offset tuning has two selectable range choices, MIN and MAX, plus an OFF position. In the MAX position, excursion is about  $\pm 4$  kHz. In the MIN position, excursion is about  $\pm 1.5$  kHz, for fine tuning. No matter what position the OFFSET control is in or what type of offset is selected, moving the selector switch to the OFF position will defeat all OFFSET functions.

The OFFSET LED indicator lights whenever the offset circuitry is in use. For instance, if TX offset is selected the OFFSET LED will be on only during transmit. Also, the digital frequency display will show the actual frequency including the offset when in use.

#### NOTCH

The NOTCH filter control adjusts the frequency of the audio notch across the passband. The NOTCH depth is at least 50 dB and will reduce carrier interference by this amount or more since the notch is inside the AGC loop. The notch circuit is effectively removed by turning the control fully cw.

#### BP\_FILTER

The BP FILTER control fades from normally flat receiver audio response to a sharp 750 Hz bandpass response. Various amounts of bandpass effect can be chosen by the degree of clockwise rotation. The filter width is 200 Hz with -24 dB/Oct skirts.

#### DRIVE

Both microphone gain and cw level are adjusted with the DRIVE control. For ssb, advance control under normal speech operation until ALC indicator lights on voice\_peaks. For cw, advance the control until ALC indicator lights on key-down. For cw, the DRIVE setting can be made in the LOCK position also. However, this setting does not hold for ssb operation since microphone type, closeness to lips, and loudness of speech all affect the ssb DRIVE setting.

#### SPOT

When this pushbutton is pressed the offset circuit is placed in its selected transmit condition. This lets the operator hear the exact frequency on which the radio will transmit.

#### VOX-QSK\_SWITCH

This switch selects either the internal VOX (voice operated transmitter) or manual PTT (push-to-talk) circuitry. Also controlled is the recovery speed of the receiver. In the VOX position, the VOX circuit controls the T/R switching (sideband only), recovery is fast. In the FAST position, PTT controls the T/R, recovery is fast. In the SLOW position, PTT controls the T/R, recovery is slow. In the cw mode, the key controls the T/R, PTT and VOX are inactive, and only the recovery is affected.

#### AGC\_SWITCH

This switch selects the recovery time of the hang AGC system, 0.2

seconds FAST, 2 seconds in SLOW, or defeats the AGC, OFF. When the AGC is off, the i-f gain is controlled by the rf gain control and the S-meter will be inoperative.

#### XTAL\_SWITCH

This switch selects the optional crystal filters installed on the PBT board. If none are installed, this switch must remain in position 3. The switch position numbers are proportional to bandwidth; 3 is widest. There are four possible filters: 2.4, 1.8, 0.5 and 0.25 kHz. The first three, if installed, are selectable in ssb mode, the last three are selectable in cw mode. The 2.4 kHz filter is standard while the 1.8 kHz (Model 288), 500 Hz (Model 285) and 250 Hz (Model 282) are optional.

#### KEYER\_SPEED

Keyer speeds from 8 to 50 WPM can be selected with the KEYER SPEED control. Also sets the memory clock rate.

#### N.B.\_LEVEL

This control sets the blanking threshold. When fully counterclockwise the noise blanker is off. Clockwise rotation increases the blanker sensitivity but beware that it is possible to set the blanker too sensitively and overload the circuit.

#### N.B.\_WIDTH

This feature allows control of the blanking gate pulse width.

#### PROCESS

The PROCESS control/switch activates the speech processor and determines the processing level. The processor increases the average speech power and allows a greater range of voice levels to attain peak ALC level. When the processor is on, the PROCESS LED indicator will light and the process level will be displayed on the meter when the METER switch is in the process position. Proper level is indicated with a half scale reading on the meter. The level of processing will affect the DRIVE to some extent. To set the processor, turn it off and while speaking into the mic in a normal voice, advance the drive until the ALC LED lights on voice peaks. Turn the PROCESS control on and advance it until the ALC LED again lights on voice peaks. This should be approximately at mid-rotation of the control. More processing can be had by further clockwise rotation but the DRIVE control must be reduced to keep the ALC action constant. Severe voice distortion, objectionable background noise and transmitted splatter will occur if the DRIVE control is not kept just to the point where the ALC LED lights on voice peaks.

#### ALC\_CONTROL

This control sets the threshold level at which the automatic level control starts. When fully clockwise, input power is factory adjusted for 200 watts on the least efficient band when the ALC indicator just starts to light. Power can be reduced below this level to approximately 80 watts input when control is fully counterclockwise. A change in ALC setting



requires a readjustment of the DRIVE setting .

## MICROPHONE

The microphone input circuit has been designed for high or low impedance microphones with maximum 5 mV output. Transistorized microphones may also be used, providing their output level is set so that the input stage is not overdriven. The cable, which preferably should provide shielding for all leads, is terminated with a standard 4 pin microphone plug. The shield and/or ground lead are connected to pin 2, the PTT switch to pin 3, and the microphone signal lead to pin 1. Pin 4 is a polarizing voltage for electret heads. Failure to shield both microphone and PTT leads may result in rf getting into the audio circuits.

FRONT VIEW

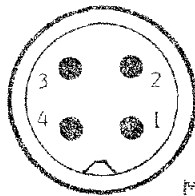

PIN ASSIGNMENTS:

- 1 MIC
- 2 GND
- 3 PTT
- 4 +V FOR ELECTRET

MICROPHONE CONNECTOR DETAIL

The PTT switch operates with respect to ground. When transmitting, the switch is closed.

## PHONES

This jack is provided for use with headphones, either high or low impedance type. When in use, the internal speaker or external speaker plugged into the rear panel jack will be disconnected. Since the power level required to drive headphones is much less than for a speaker, an attenuator network is incorporated in this circuit. This permits the audio amplifier to operate at its optimum signal to noise setting.

## WWV

Broadcasts of WWV may be received on 10 MHz for checking the accuracy of the time base oscillator in the CORSAIR II. In addition, WWV broadcasts propagation reports and time verification.

- 1.) Set BAND switch to 10.0 MHz.
- 2.) Rotate Main Tuning Knob so that frequency readout is 10.0000 MHz.
- 3.) Set XTAL switch to 2.4.
- 4.) Set MODE switch to SB-N.
- 5.) Zero beat the WWV signal. The digital readout should read 10.0000. If it does not, the time base oscillator may be adjusted as outlined in SECTION III.

## MOBILE OPERATION

The CORSAIR II is ideally suited for mobile operation in a car, boat plane, or other vehicle. It operates directly from a 12 volt battery source and is self-contained except for key, microphone, and antenna. When operating from any power source other than a TEN-TEC power supply, the protective circuitry for the final amplifier is not present. Model 1140 Circuit Breaker is required in series with the +12 volt supply line. The Model 1140 Circuit Breaker will function as both an external on-off switch and an over-current protection device for the final amplifier.

The SWR meter is especially useful in setting mobile whip antenna lengths to the operating frequency.

When using an alternator charged battery, start and stop the vehicle's engine with the CORSAIR II turned off. This prevents any high voltage transients, caused by momentarily open regulator contact, from being applied to the transceiver circuits.

## FIXED STATIONS

The CORSAIR II, with conventional antennas, will perform with distinction in any ham shack. With a linear amplifier, power can be increased to any value desired up to the legal limit. For an emergency or stand-by station, it will operate for long periods of time with a 12 volt automobile storage battery. Increased operating time can be achieved by setting the ALC control down from its maximum position.

## BAIL STAND

The movable bail is primarily intended to raise the front panel to a convenient slanting position. In this position, the speaker output is effectively radiated forward due to the "V" formed by the transceiver bottom and the table top.

The bail may also be used as a carrying handle, but care should be taken to prevent deforming it.

## OPERATING HINTS

- 1.) When setting up the station, provide adequate ventilation for the heat sinks on the transceiver and power supply. Do not confine units to a small volume without forced ventilation to circulate cool air around the heat sinks.
- 2.) When operating RTTY, SSTV, or other high duty-cycle modes, it is recommended that a small fan be directed on the heat sink. The sink temperature may reach as high as 200 degrees Fahrenheit, which is still within the rating for the transistors, but certainly hot enough to cause a serious burn if touched.
- 3.) The CORSAIR II may be operated as a QRPp transceiver simply by adjusting the DRIVE control downward. To determine input power, observe the collector current meter, IC. For every ampere increase over the no-drive quiescent level in the LOCK position of the MODE switch, the power input to the final amplifier is increased by

about 13 watts. For example, assuming that the quiescent current is 2 amperes, a 4 ampere reading on the ammeter indicates 26 watts input.

- 4.) The S-Meter will be accurate only when rf control is fully clockwise. The meter is factory calibrated for a 50 uV reading at S9 on the 14 MHz band.
- 5.) To determine SWR, set MODE switch to LOCK position, ALC control fully clockwise, and advance DRIVE control until ALC indicator lights. Read SWR on lower scale with METER switch in SWR position.
- 6.) Sidetone level and pitch controls are accessible through finger hole located on bottom plate.
- 7.) In the cw mode, the indicated frequency is the received frequency. To accurately read an incoming frequency, therefore, it is necessary to zero beat the signal, not peak it on the S Meter. This holds true no matter where the OFFSET control is set. When transmitting cw, the indicated frequency will be 750 Hz removed from the true transmitted frequency due to the BFO shift to bring the oscillator into the filter pass band. This shift will be in the same direction as the shift when working the SB-R mode, i.e. the indicated frequency will be higher than the transmitted frequency for the frequencies below 14 MHz, and lower for frequencies of 14 MHz and above. Due to the 750 Hz switch in frequency, every time the key is actuated when using the CORSAIR II, an accurate transmitted frequency count cannot be made while sending code. To accurately determine the transmitted frequency, make the reading in LOCK or key-down condition and either add or subtract 750 Hz from the reading, depending on the band in use. (Example: To set up a transmitting frequency of 3.545 0 MHz, place MODE switch in LOCK position and adjust tuning for a reading of 3.545 7 MHz. For 14.062 0 MHz, set readout to 14.061 3 MHz.)
- 8.) Increasing the DRIVE setting over that required to just light ALC indicator will not result in any appreciable increase in power out. However, overdrive may increase ssb distortion products and destroy cw keying characteristics.
- 9.) In order to eliminate the internal, spurious 28.980 MHz signal found in the 28.5 to 29.0 band segment, change BAND switch to 29.0 to 29.5 band segment and tune below the lower edge of this band segment for 28.980 MHz.
- 10.) The VFO oscillator, like any LC tuned oscillator, may be adversely affected by ac magnetic fields cutting the coil turns. The oscillator output is frequency modulated at the line frequency, causing a "dirty" cw note and/or poor ssb quality in both transmit and receive modes. When installing the CORSAIR II locate any ac operated equipment which may generate magnetic fields, such as power supplies, electric clocks, keyers, rotator controls, and other station accessories as far as possible from it. Since the VFO is located front and center, the most common cause of FMing is from placing these accessories on top of the unit. A check of purity of a received cw signal should be made at the time of

installation.

- 11.) Due to the possibility of high voltage transients being generated in the output rf amplifier during bandswitching, changing bands should not be done while transmitting power to the load. Either place the CORAIR II in the receive mode or be certain of a key-up condition in cw. YOU RISK THE POSSIBILITY OF DESTROYING THE OUTPUT TRANSISTORS IF THIS PRECAUTION IS NOT OBSERVED.
- 12.) Although improper antennas will not damage the finals, we suggest an SWR below 2 to 1 be achieved for maximum performance. In cases where the antenna cannot be matched to a better SWR, and the TEN-TEC Power Supply repeatedly shuts down due to over-current conditions, the CORASIR II can be operated at reduced input power by rotating the ALC control counterclockwise to a position where the supply does not trip out. Be sure to readjust DRIVE control after reducing the ALC control.

#### AN IMPORTANT MESSAGE

To obtain top performance from your CORASIR II we feel that you should be briefed on new technology such as solid state no-tune rf amplifiers. Misconceptions sometimes arise from incomplete knowledge which results in erroneous conclusions being drawn that the equipment is faulty, erratic, or not performing to specifications. It is the purpose of this message to inform you in these areas so that you can knowledgeably approach and correct any apparent improper performance characteristic.

#### Ten Points to Observe When Installing The CORSAIR II

- 1.) The transmitter will give best performance when properly loaded.
- 2.) Even though the output transistors are resistant to damage from improper loads, they will not operate satisfactorily under all load conditions and will not operate to specifications.
- 3.) The output transistor dissipation will increase if the CORSAIR II is not properly loaded.
- 4.) Reactive impedance components in the antenna are applied to the transistors and may cause parasitic oscillations.
- 5.) A given SWR reading does not tell you anything about the reactive components and is not accurate unless the load is a pure resistance.
- 6.) A given SWR indicates one of two possible impedances. Each acts differently on the transceiver's performance.
- 7.) The most efficient operating point is when the load is 50 ohms, resistive.
- 8.) The ALC light is not an indication of the input power, but output

power. It may not light even though the power supply is delivering enough current to trip the breaker.

- 9.) If the breaker repeatedly trips, it is an indication that the load is enough removed from optimum so as to cause high transistor dissipation.
- 10.) It is possible for the power supply regulator to drop out of regulation just prior to its tripping the breaker with low ac line voltages, (brown-outs or long ac power runs). Under these conditions, hum modulation will appear on the transmitted signal. With proper load and line voltage, the current drain will be considerably below the tripping point so no hum should appear on the carrier.

### Technical Facts of Life

Although vacuum tubes and transistors both can be made to amplify rf power, there are some fundamental differences in how this is accomplished. A better understanding of what we can expect under various operating conditions will aid in recognizing correct or incorrect performance.

- 1.) Broadband vs Resonant Tanks - Almost all tube circuits use resonant tanks in the plate circuit. The CORSAIR II uses a broadband system. In class AB operation, these two approaches act similarly without drive being applied. The idle current is relatively low and within the device dissipation rating, even with load impedance variations from open to short circuit.

However, with drive applied, the two act very differently. In the case of tubes, the dissipation within the tube depends on both the tuning of the tank and the load applied. If the tank is resonated and the load is very light, the internal power dissipated is quite small as indicated by the null which reduces plate current almost to the level with no drive. Out of resonance, the plate current, and hence dissipation, increases rapidly and may damage the tube from overheating. In resonance, as the load is increased, the null becomes more shallow at a higher plate current as a result of the power being delivered to the load. As the tank is tuned to resonance, the load impedance which is usually on the order of 50 ohms is transformed to a relatively high impedance of several thousand ohms to match the plate circuit impedance. Small load reactive components--either capacitive or inductive--can usually be balanced out in the tank resonating function.

With transistors, drive applied and no load, there is no resonant high impedance to limit the collector current, and so power is poured into the circuit (much as the out-of-resonance tank condition). Since there is no load power, all has to be dissipated in the transistor. So even with no load, the power supply circuit breaker may trip. The broad-band transformer system used with transistors transforms the 50 ohm load impedance not higher, but much lower (in the order of 4 or 5 ohms) to match the transistor output impedance. Since this transformation is fixed in design, any reactive component in the load impedance is

## TEN-TEC MODEL 238B



# Lowest loss tuner

The Ten-Tec model 238B is a 2000 watt roller inductor antenna tuner featuring the lowest insertion loss of any commercially available antenna tuner today. Our use of an "L" network configuration assures a low Q match. Low Q means low circulating currents, hence low loss, and provides the widest frequency bandwidth of operation before retuning is necessary. 2000 watts PEP or CW, 4 position antenna switch, power/SWR metering, built-in 4:1 balun for ladder line use. See antenna tuner comparison article in Feb. 2003 QST for an objective report.

**Backed by a 3 year parts and labor warranty!**

Call or email for additional information! **\$649**

**1185 Dolly Parton Pkwy., Sevierville, TN 37862**

**Sales: 800-833-7373 [www.tentec.com](http://www.tentec.com)**

Office (865) 453-7172. FAX (865) 428-4483.

Sales: Mon-Fri 8-5:30 EST [sales@tentec.com](mailto:sales@tentec.com).

Service: Mon-Fri 8-5 EST [service@tentec.com](mailto:service@tentec.com) (865) 428-0364.

Shipping is additional. TN residents add 9.5% sales tax

**TEN-TEC**

applied in a transformed way to the collector circuit. Certain reactances at this point, especially inductive, give rise to parasitic oscillation. To correct for this, the antenna impedance should be changed to remove this reactance, or a matching network should be inserted between antenna and transceiver. It is important to remember that any antenna changes its impedance with frequency, so that one that resonates well at one end of the band may well cause oscillations to trip the circuit breaker on the other end. If entire band operation is desired, especially on the lower bands, the adjustable matching network would be the better choice, rather than to try to make the antenna behave over the entire band on a cut-and-try basis.

A final point to bring out regarding broadband vs tank systems is that there is a limit to the amount of current that you can draw from an emitting filament, and this saturation current will limit the amount of power drawn from the supply. In the case of transistors, where the collector internal impedance is only a fraction of an ohm, extremely high currents can be demanded of the power supply, especially with mismatched loads well below 50 ohms. A fuse is provided in the CORSAIR II for protection when operating from a power source that is not limited.

2.) SWR - Two Kinds - The standing wave ratio is a direct measure of the ratio between two impedances, i.e. a SWR of 3 to 1 tells us that one impedance is three times the other. Therefore, the unknown impedance can be either three times as large or three times as small of the known one. If the desired impedance that the transceiver wants to see is 50 ohms, SWR of 3 to 1 on the line may mean a load impedance of either 150 ohms or one of 17 ohms. If it is 150 ohms, the transmitter will act differently than if it is 17 ohms. In the first case, the power demanded from the power supply will be much lower, and will not be large enough to trip the supply. In the second case even though the SWR reads the same, the supply may repeatedly trip out. The SWR reading gives no indication of reactive components, nor can it separate the resistive from the reactive components. It is calibrated with a pure resistive load and therefore has its greatest accuracy with pure resistive loads. The SWR bridge should be used only as an indicator when attempting to adjust antenna system to a pure 50 ohm resistive impedance at the transmitter output point.

3.) Efficiency - Since transistor amplifiers have a very low value of output impedance, they act more or less as a constant voltage source. That is, the rf output voltage tends to remain at a fixed value regardless of the load impedance. Hence, the output power will vary depending on the value of the load, and increase as the load impedance goes down. It can be seen that a 3 to 1 SWR on the low side of 50 ohms will ask the amplifier to deliver much more power than a 3 to 1 SWR on the high side. Since the amplifier does have a finite value of output impedance, the amount of power delivered to the load with efficiency will change with load. Unless the load is near the design value, the transistors will heat up unnecessarily without delivering any more power to the antenna.

- 4.) Protective Circuitry and ALC - ALC serves three major functions. It assures the maximum power from the transmitter without careful adjustment of the input drive, it prevents the amplifier from being overdriven into the non-linear, distortion-producing area, and it serves as a power limiting device which protects the output transistors. It does the first two very well, but the third only partially. To absolutely protect the system, we add the current limiting circuitry to the power supply, or a fast acting magnetic circuit breaker in the dc supply line.

The ALC system senses the power output and adjusts drive accordingly. Note that it does not sense the power into the final. Therefore, some load conditions may exist where the ALC system will not limit the transistor dissipation. One instance is where there is a highly reactive load. It is not possible to make a purely reactive load absorb power, so the ALC light will not go on, even though high power is being supplied to the final in the way of internal dissipation.

Under these condition, the power supply protective circuits take over and trip the breaker. So it is very possible that the breaker will repeatedly trip without the ALC light going on. If this occurs, it indicates a change in the antenna system or matching network is needed.

A final comment regarding the situation--when the breaker in the power supply trips, the amount of current drawn from the supply may be high enough to cause the supply to drop out of regulation, especially with low line voltages. Under these conditions, the output may become hum modulated. The output light on the power supply will also start to dim a bit. This condition should be rectified by antenna and/or matching changes since the emitted quality of the signal will be poor. (Whereas the breaker will trip in the LOCK position, it probably will not with cw or ssb, even though the regulator drops out and produces poor quality signals.)

If the above precautions are observed, we are sure that you will be more than delighted with the performance of your CORSAIR II.

#### Recommended Reading

- 1.) ARRL HANDBOOK
- 2.) Antenna Handbook, Ken Glanzer, Cowan Publishing



## SECTION III

### ALIGNMENT AND SERVICE

#### GENERAL

This section covers maintenance and service of the CORSAIR II transceiver. It includes information on trouble analysis, signal tracing and alignment procedures. Connector and transistor voltages are given for most subassemblies. Readings should be within 15% of the listed value when measured with a dc voltmeter with at least 20,000 ohms-per-volt impedance. All readings are dc and positive with respect to chassis ground unless stated otherwise. Except for occasional touch up to compensate for possible component aging, alignment normally will be necessary only if frequency determining components have been replaced.

When removing a particular assembly, note the orientation of the board in the chassis so that it can be replaced correctly. Many assemblies can be inadvertently inserted incorrectly if care is not taken. Figures 3-1 and 3-2 show correct placement of each assembly. To remove a board unplug all connectors and then remove the screws fastening it to the chassis. Note the number of connectors present and their orientation within the wiring harness. All chassis connectors are keyed for proper insertion but can be forced incorrectly. Each cable connector is numbered along with its corresponding connector on the board.

To facilitate location of the various components that may require alignment or adjustment refer to the table below:

FUNCTION	ASSEMBLY	LOCATION
Rx input coils	BFF, 80976	Bottom
Mixer balance	RF-MIXER, 80987	Bottom
Passband tuning center	PBT, 80979	Top
Rx i-f amp	IF/AF, 80984	Bottom
S-meter adjust	IF/AF, 80984	Bottom
Sidetone pitch & level	IF/AF, 80984	Bottom
Counter calibration	COUNTER BOX, 81243	Top
OFFSET zero adjust	CONTROL BOARD, 80978	Bottom
Carrier null	DSB, 80980	Top
CW TX offset	DSB, 80980	Top
ALC 100 w set	LOW LEVEL DRIVER, 81037	Top
SWR null	SWR, 80970	Bottom
SWR calibrate	SWR, 80970	Top
FWD power calibrate	SWR, 80970	Top
External t/r relay delay	CONTROL, 80878	Bottom
Final amp bias set	FINAL BIAS, 80575	Top
Driver bias set	FINAL AMP, 80565	Bottom
ALC LED threshold	LDW LEVEL DRIVER, 81037	Top
Collector current calibrate	SHUNT, 80987	Bottom
10/15 Meter offset	OSCILLATOR/MIXER, 80975	Bottom

L.O. mixer null  
PROCESSOR Gain  
PROCESS meter calibrate  
Noise blanker width

OSCILLATOR/MIXER, 80975  
VOX, 80981  
VOX, 80981  
NOISE BLANKER, 80977

Bottom  
Top  
Top  
Top

## PARTS LIST

Below most schematics is a list of the main parts on each circuit board. Common parts such as fixed resistors, which are readily available, are not listed.

## REMOVAL OF TOP COVER

Remove the upper two of the four Phillips screws located on each side. Slide the top back and out from under the rear lip of the extruded aluminum frame.

## REMOVAL OF BOTTOM COVER

Remove the lower two of four Phillips screws located on each side. Remove the single Phillips head screw nearest the rear panel, on the bottom surface. With the unit upside down and front panel facing towards you, slide the bottom cover out from underneath the rear lip of the extruded aluminum frame. **CAUTION:** Speaker wires will limit removal of the bottom cover. Unsolder the speaker cable at the speaker terminals before removing the bottom cover.

## DIAL SKIRT REMOVAL AND REPLACEMENT

The main tuning dial skirt is friction mounted to the shaft and can be easily removed by pulling it straight off the shaft after the plastic knob is removed. Two felt washers between the knob and skirt provide a slight amount of friction to eliminate any backlash between the two.

To replace the dial skirt construct a loop of thread, fishing line or dental floss and hook it under the straight side of the D-shaped retaining spring. Start the skirt onto the tuning shaft and pull the loop to expand the spring. Seat the skirt as far back as it will go and remove the loop from behind the skirt.

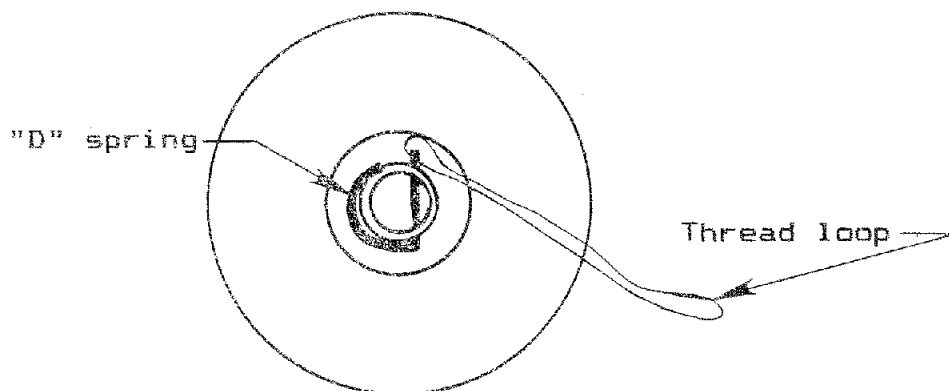

Rear view of dial skirt

## REMOVAL OF THE FRONT PANEL

First remove the top. Remove the bandswitch knob using the 6-32 allen wrench provided. Then remove the main tuning knob, dial skirt and remaining knobs using the 4-40 allen wrench. Remove the small control knobs by pulling forward. Using an appropriate wrench or a large pair of pliers, remove the nuts from the PHONES and MIC jacks. Now remove the four screws holding the front to the sub-panel. Be sure to save the black decorative washers that are in front of the 5 toggle switches. Remove the decorative nut around the spot switch. Unplug the meter from the socket on the meter switch.

## PILOT LAMP REPLACEMENT

The CORSAIR II uses a single pilot lamp mounted behind the meter. It is a standard 14 volt bayonet type #1892. Access to this bulb is by removing the top cover.

## FUSE REPLACEMENT

The fuse is located on the inside of the low pass filter compartment and protects the CORSAIR II from heavy overload and reverse polarity conditions. Replace with a type 3AG fast-blo 20 ampere type.

## ROTARY SWITCH CARE

The bandswitch wafers are specially lubricated by their manufacturer for maximum useful life. Brushing on or dipping or spraying the switch with solvents will wash away the special lubricant and dramatically shorten the life of the switch. Cleaning rosin from soldered connections is not recommended since there is a hazard of the desolved resin flowing into the switch causing intermittent problems. Never use commercial contact cleaners on these switches unless proper lubrication is restored. In almost all cases, intermittent switch connection problems can be traced to improper switch shaft alignment or loose shaft couplings.

## MAIN CHASSIS

The chassis wiring is color coded wherever possible.

COLOR	FUNCTION	VOLTAGE, RX	VOLTAGE, TX
Black	GND	0	0
Red	+13	13.0	13.0
Orange	+REG	7.9	7.9
Yellow	R	12.0	0
Blue	T	0	12.0

MODEL 561 TOP VIEW

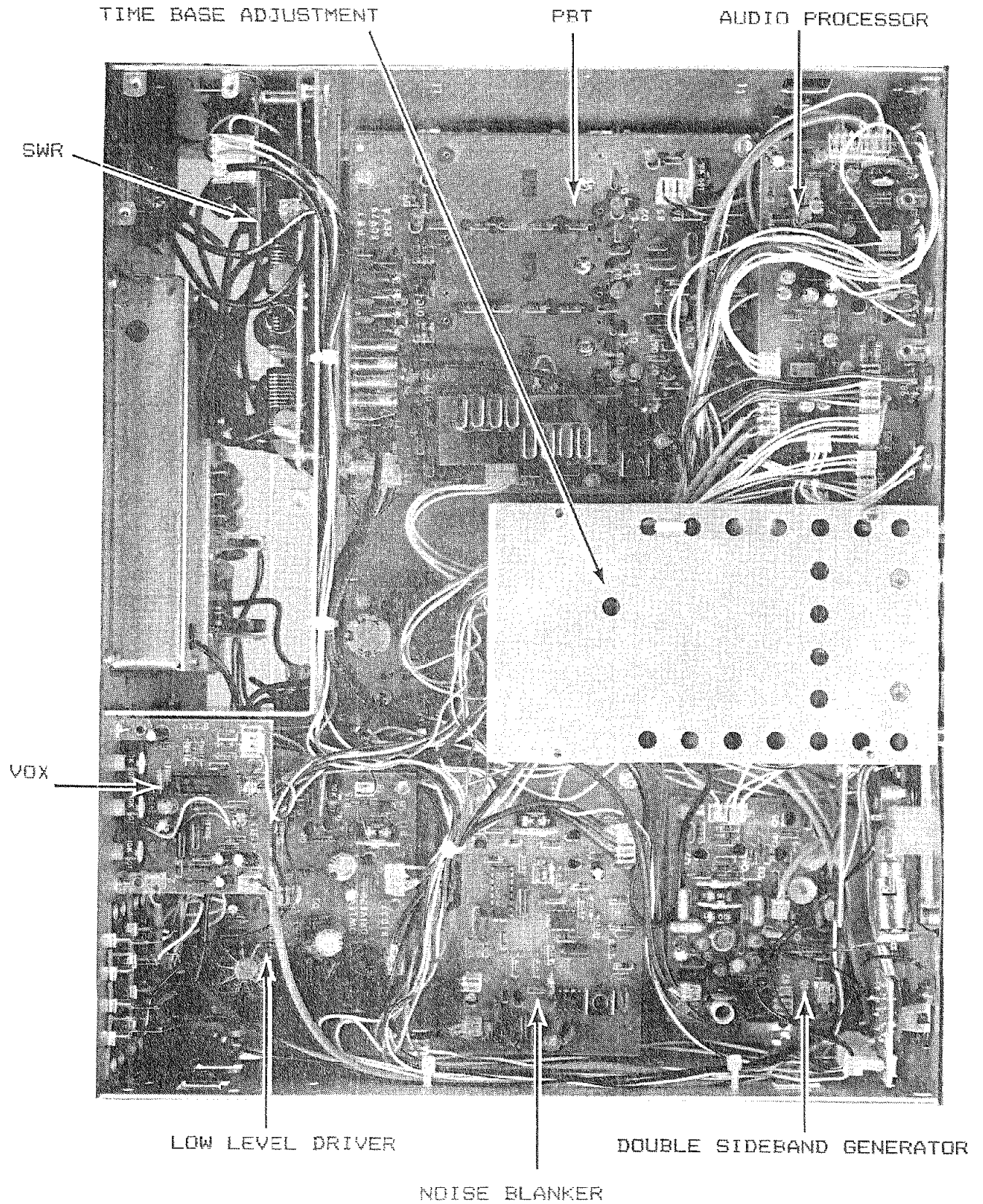

MODEL 561 BOTTOM VIEW

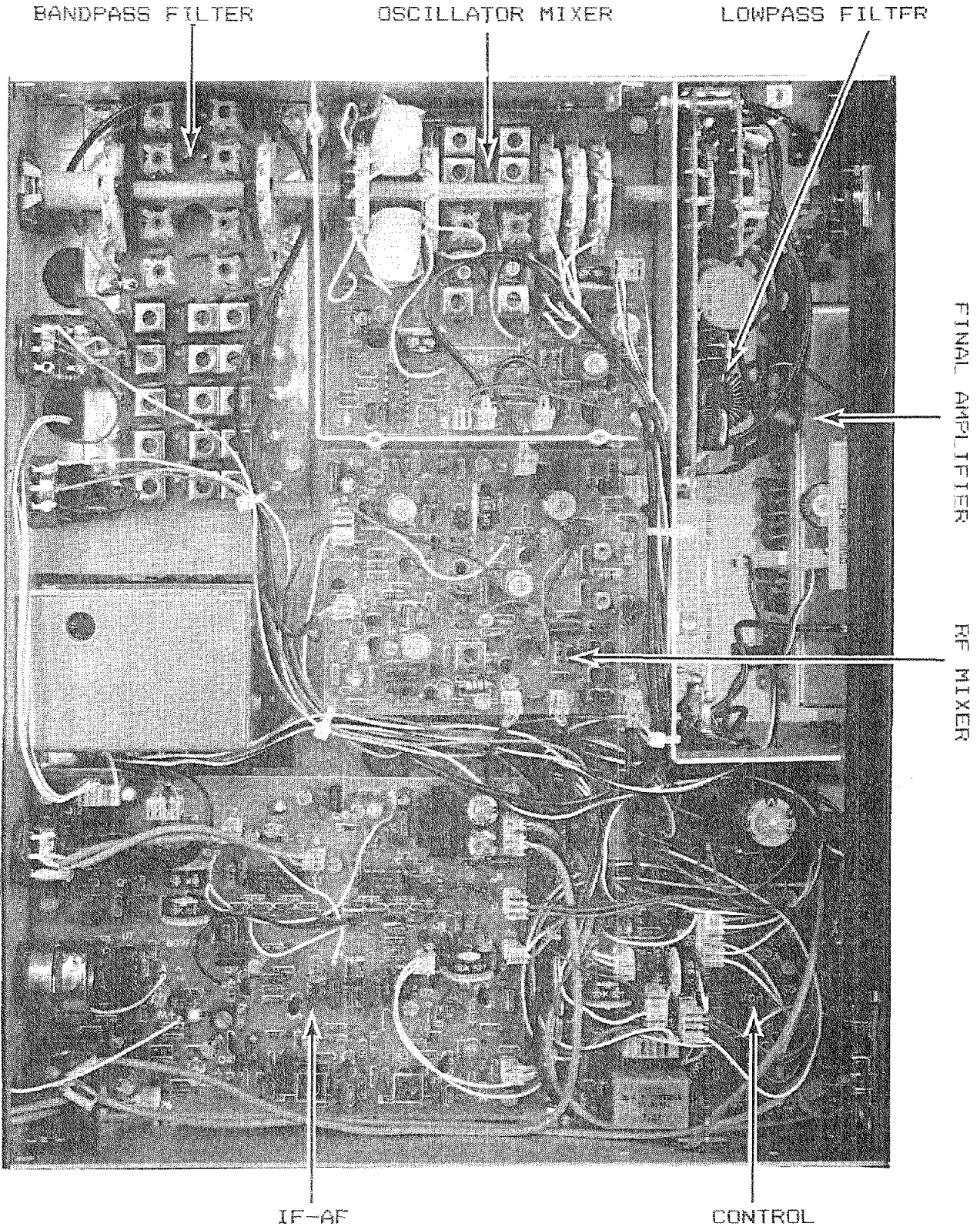

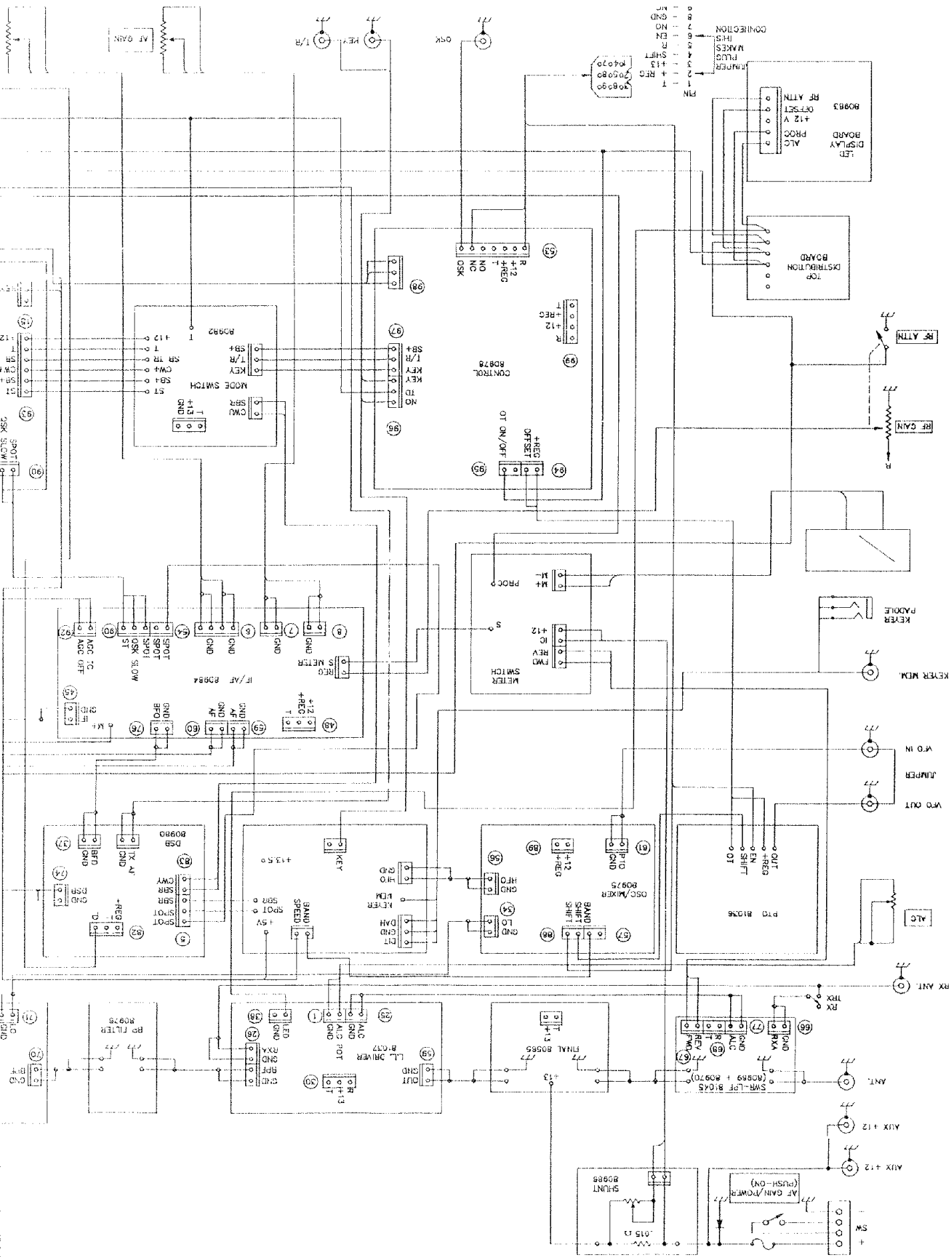

CONNECTOR

1	+	REC
2	+	REC
3	+	REC
4	+	REC
5	+	REC
6	+	REC
7	+	REC
8	+	REC
9	+	REC
10	+	REC
11	+	REC
12	+	REC
13	+	REC
14	+	REC
15	+	REC
16	+	REC
17	+	REC
18	+	REC
19	+	REC
20	+	REC
21	+	REC
22	+	REC
23	+	REC
24	+	REC
25	+	REC
26	+	REC
27	+	REC
28	+	REC
29	+	REC
30	+	REC
31	+	REC
32	+	REC
33	+	REC
34	+	REC
35	+	REC
36	+	REC
37	+	REC
38	+	REC
39	+	REC
40	+	REC
41	+	REC
42	+	REC
43	+	REC
44	+	REC
45	+	REC
46	+	REC
47	+	REC
48	+	REC
49	+	REC
50	+	REC
51	+	REC
52	+	REC
53	+	REC
54	+	REC
55	+	REC
56	+	REC
57	+	REC
58	+	REC
59	+	REC
60	+	REC
61	+	REC
62	+	REC
63	+	REC
64	+	REC
65	+	REC
66	+	REC
67	+	REC
68	+	REC
69	+	REC
70	+	REC
71	+	REC
72	+	REC
73	+	REC
74	+	REC
75	+	REC
76	+	REC
77	+	REC
78	+	REC
79	+	REC
80	+	REC
81	+	REC
82	+	REC
83	+	REC
84	+	REC
85	+	REC
86	+	REC
87	+	REC
88	+	REC
89	+	REC
90	+	REC
91	+	REC
92	+	REC
93	+	REC
94	+	REC
95	+	REC
96	+	REC
97	+	REC
98	+	REC
99	+	REC
100	+	REC



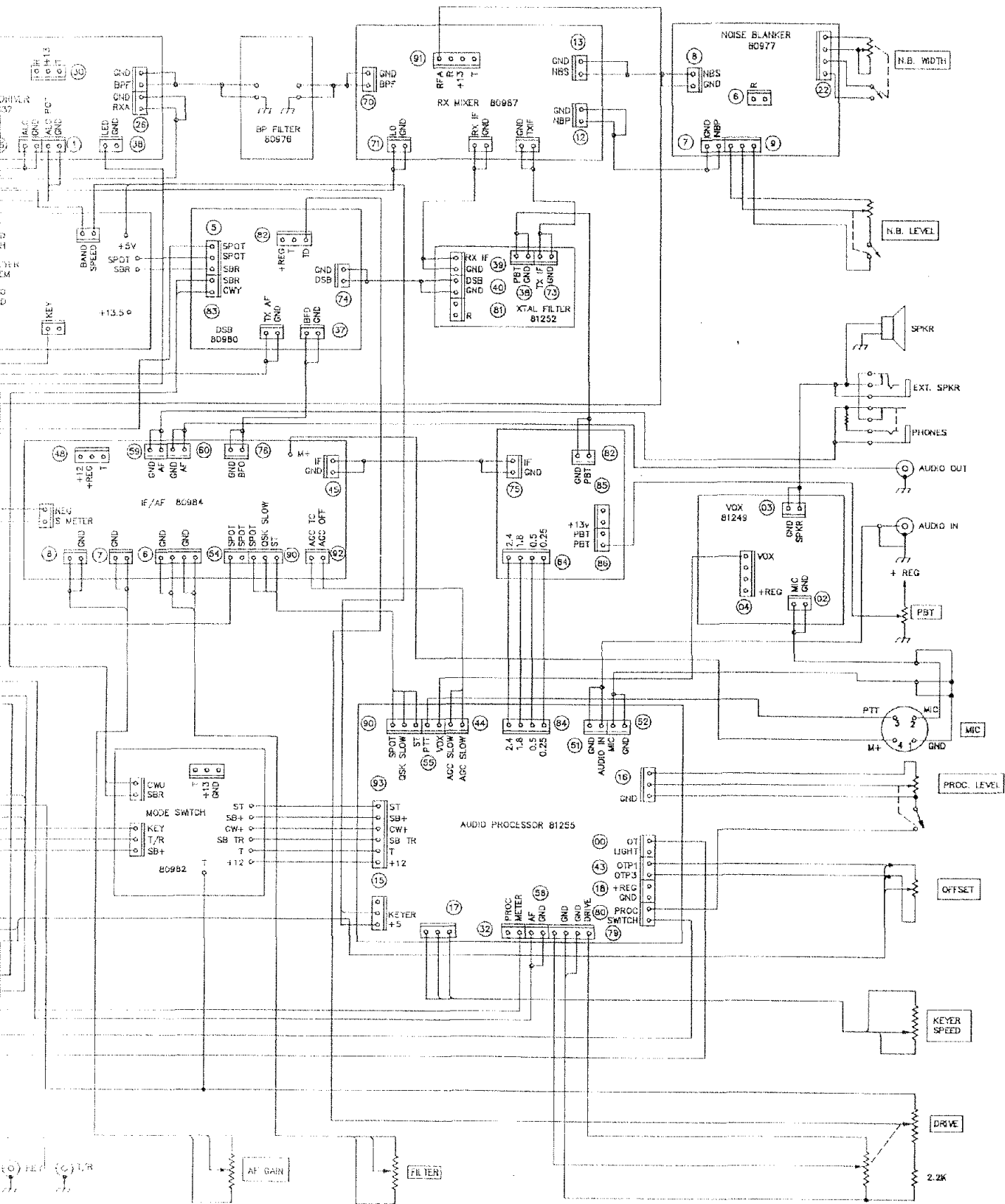





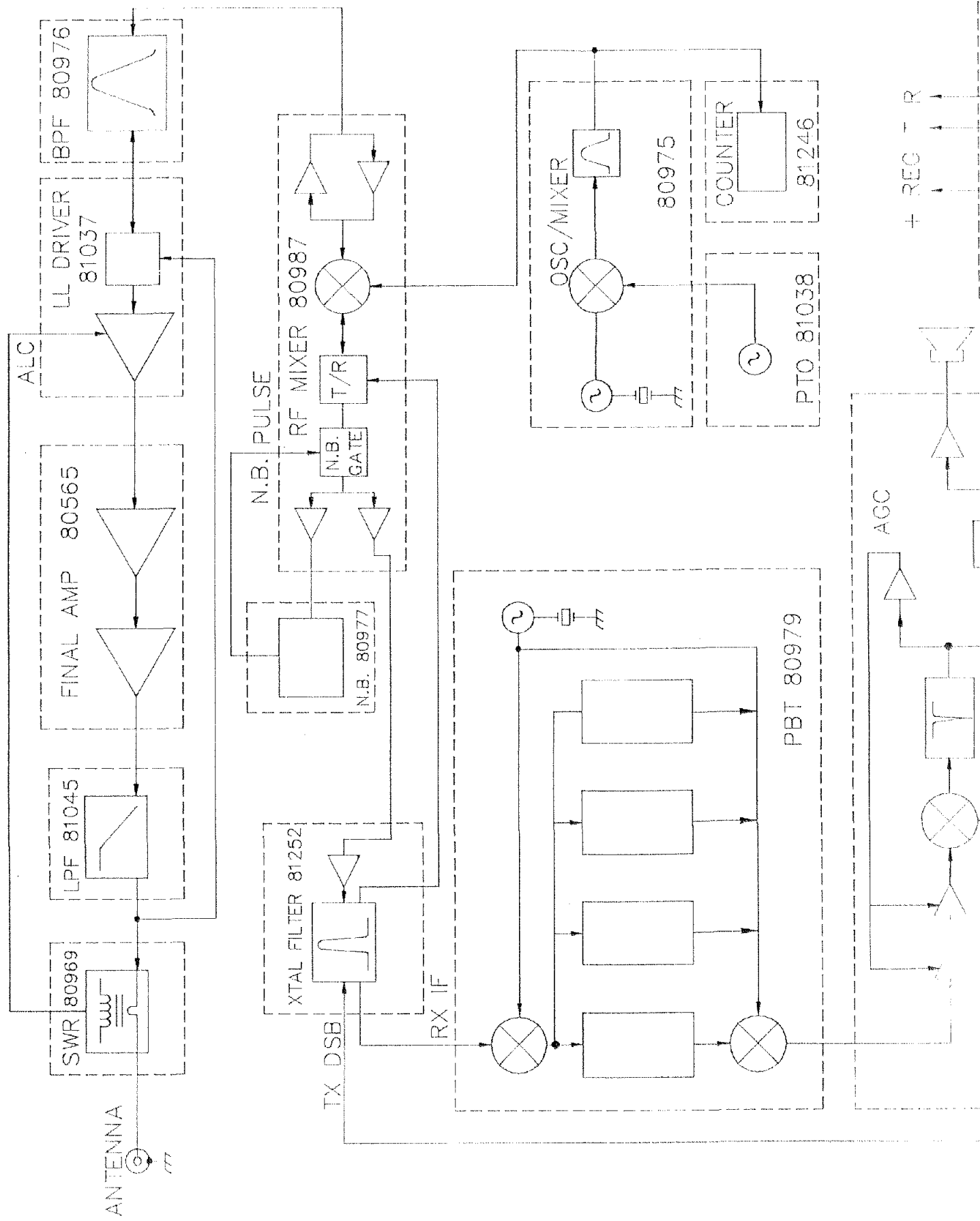



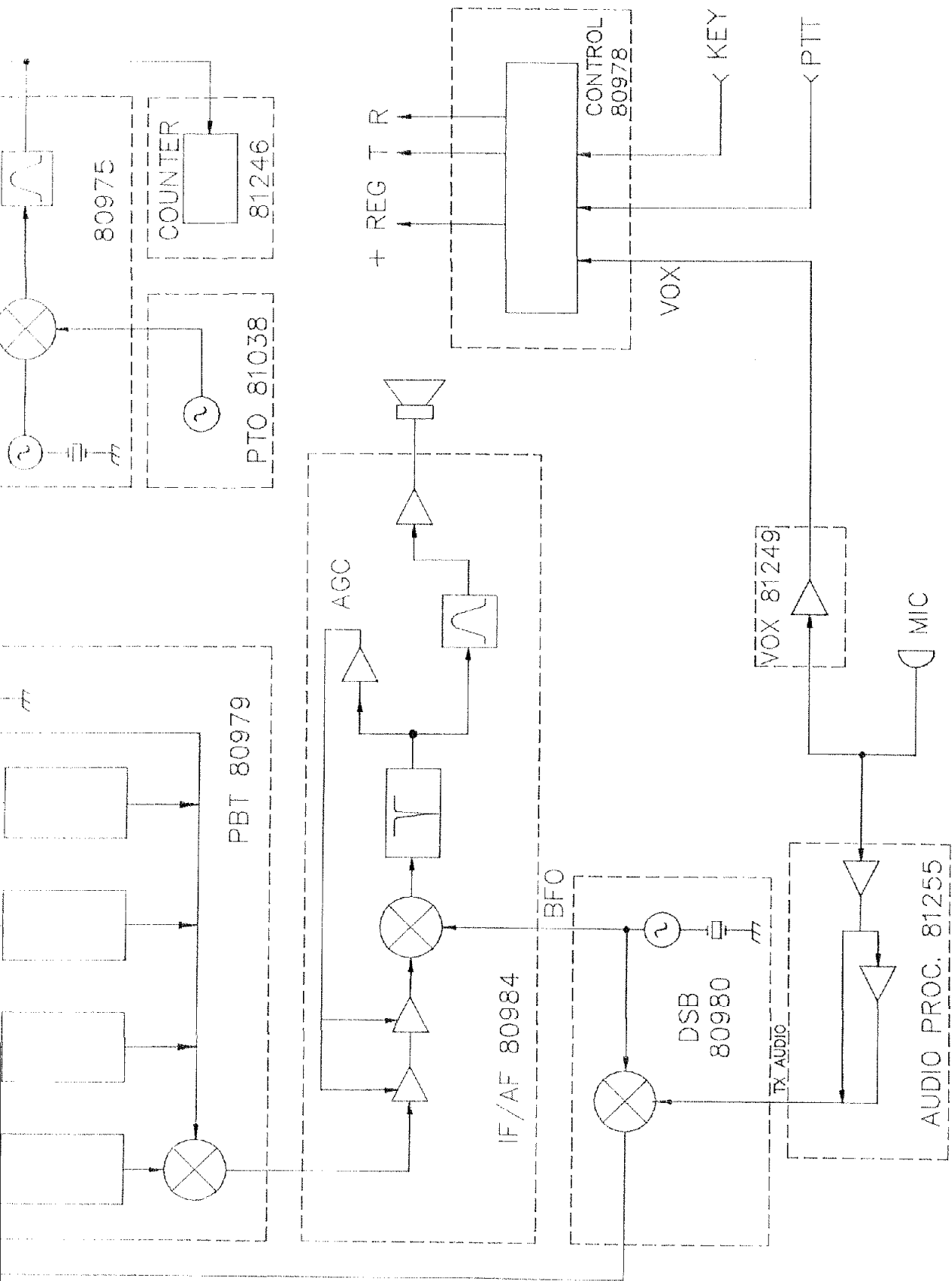



## SEMICONDUCTOR PIN IDENTIFICATION

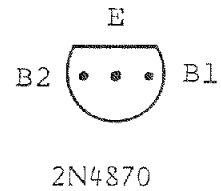
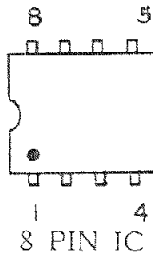
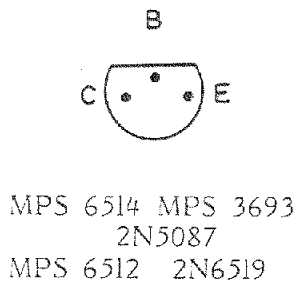
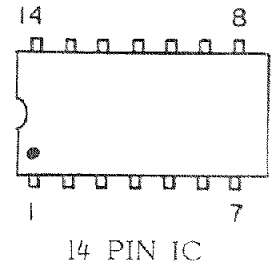
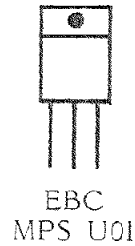
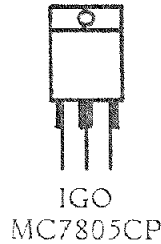
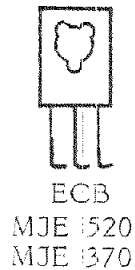
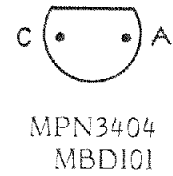
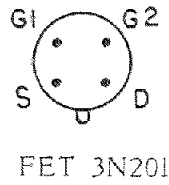
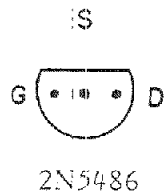
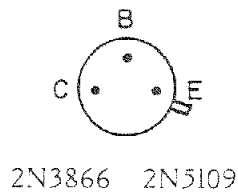

PINS VIEWED FROM TOP  
OF PC BOARD.

### PTO 81038

The Permeability Tuned Oscillator (PTO) provides the variable part of the local oscillator signal in both receive and transmit. Its 5.0 to 5.5 MHz output is mixed with a crystal oscillator, selected by the BAND switch, for translation to the proper LO frequency. The PTO is housed in an extruded aluminum housing and mounted to the front sub-panel. The PTO tuning coil, L3, is in series with L1 and in parallel with L2. Adjustment of these two slug-tuned coils, which are both wound on the same coil form, determines the linearity and band edge points.

## PTO\_ALIGNMENT

To test the alignment of the PTO turn the OFFSET function switch OFF, set the BAND switch to 14.0 MHz and set the MODE switch to SBN.

- 1.) Run the tuning knob fully counterclockwise and check that the display indicates approximately 13.960 MHz. The CORSAIR II PTO will normally tune from 35 to 45 kHz below each band.
- 2.) Next tune up to exactly 14.000 MHz and align the dial skirt "0" marking with the front panel bezel. The dial skirt is friction mounted on the tuning shaft and can be rotated independently from the tuning knob.
- 3.) Tune up the band and compare the display to the dial skirt every 100 kHz. The frequency display should correspond to the dial skirt markings within  $\pm 4$  kHz. If the final display reads above or below 14.500 MHz the PTO range can be corrected by trimming L1 and L2.
- 4.) If the PTO range is compressed i.e. the display reads less than 14.500 MHz, tune back to 14.000 MHz and adjust L2 a fraction of a turn clockwise. (L2 is controlled by the slug nearest the PTO cover). Bring the display back up to 14.000 MHz with a clockwise adjustment of L1. (The L1 slug is in the same coil form and can be reached with the reduced shank tuning tool provided with the CORSAIR II.) Now tune back up to 14.500 MHz, according to the dial skirt, and check the display again. Within two or three iterations both upper and lower band edges can be set almost exactly.
- 5.) If the PTO range is expanded according to the display return to 14.000 MHz as in Step 4 and adjust L1 and L2 counterclockwise.

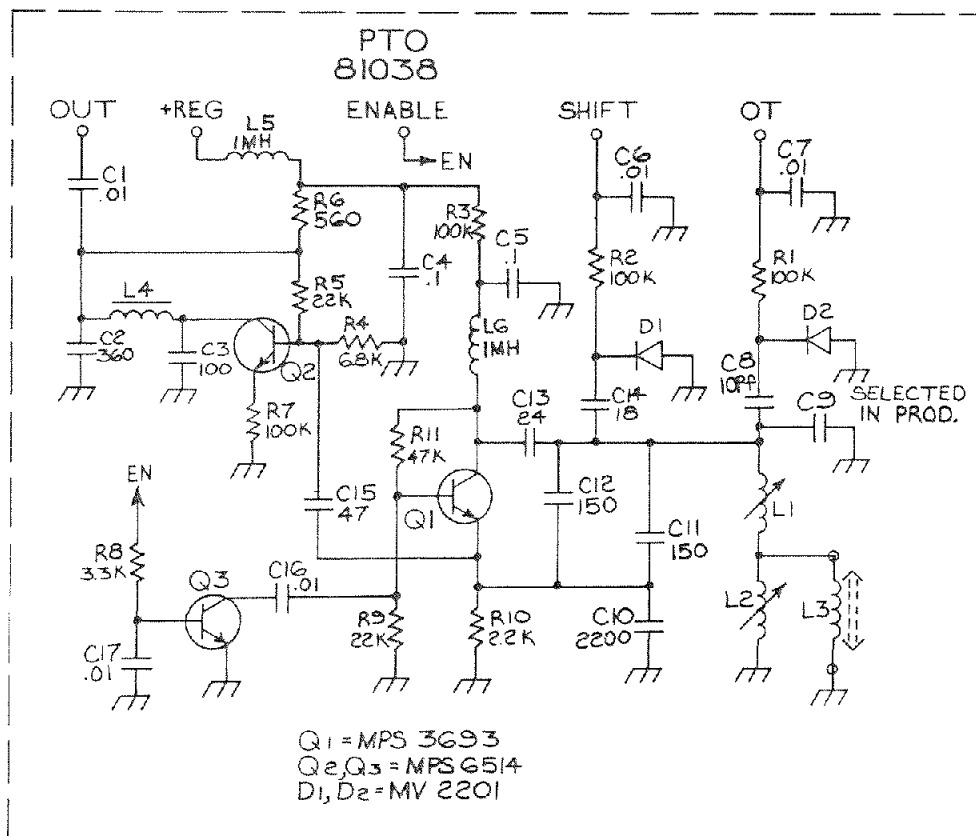

## OSCILLATOR MIXER 80975

This assembly generates the proper local oscillator frequency for each band. The PTO 5.0 to 5.5 MHz signal is mixed with a crystal oscillator in the TL442CN integrated circuit double balanced mixer. Crystals are selected by the bandswitch except on 14.0 MHz where the PTO signal is used directly. The mixer output is filtered for each band with a double-tuned resonant circuit selected by the bandswitch. These are overcoupled tuned circuits that are best aligned using a swept oscillator. Because they are wide band however realignment is seldom necessary except when a tuned circuit component is replaced.

To eliminate band edge birdies on the 10, 21 and 28 MHz bands, the crystal oscillator frequencies are chosen 10 kHz lower than what normally would be needed. The OSC/MIXER board compensates for this 10 kHz deviation by changing the bias on a varactor diode in the PTO circuit by means of switch S1E. As a result, the kHz portion of the dial reading will not change when switching from band to band. The amount of capacitance inserted by the varactor diode is controlled by the value of the dc voltage obtained from potentiometer R3. This resistor is adjacent to connector 88. To set this adjustment, proceed as follows:

- 1.) With power removed from the transceiver follow the instruction for removal of the bottom cover and remove the cover from the oscillator mixer itself.
- 2.) Apply power to the transceiver and set the bandswitch to 10.0 and the frequency dial to 10.0000.
- 3.) Switch the bandswitch to 14 MHz and without touching the main tuning dial adjust R3 so that the display reads 14.0000.

01

PIN	VOLTAGE		PIN	VOLTAGE	
	RECEIVE	TRANSMIT		RECEIVE	TRANSMIT
1	0	0	8	0	0
2	10.5	12.0	9	4.2	4.2
3	10.0	10.0	10	5.2	5.2
4	6.1	6.1	11	6.2	6.2
5	4.1	4.1	12	6.3	6.3
6	0	0	13	10.0	10.0
7	0	0	14	10.0	10.0

TRANSISTOR	COLLECTOR (drain)		BASE (gate)		EMITTER (source)	
	RECEIVE	TRANSMIT	RECEIVE	TRANSMIT	RECEIVE	TRANSMIT
Q1	8.0	8.0	0	0	2.2	2.2
Q2	9.5	9.5	4.2	4.2	3.9	3.9
Q3	11.0	11.0	11.0	11.0	10.0	10.0
Q4	9.5	9.5	3.9	3.9	3.0	3.0
Q5	12.0	12.0	2.4	2.4	1.8	1.8



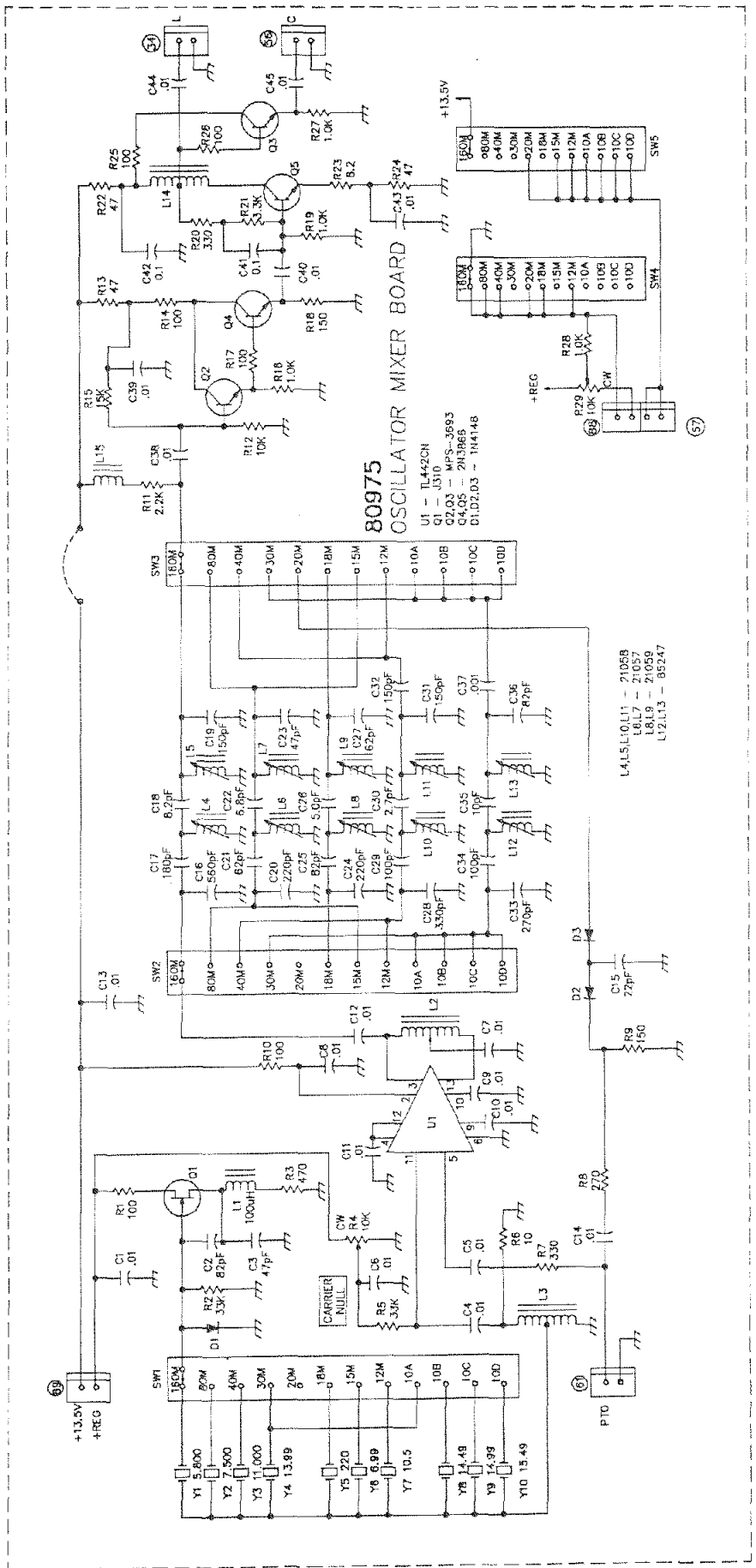

# INTRODUCING OMNI-VII



## Imagine a rig

Imagine a rig...sitting on the desk in your ham shack. After tuning to a clear frequency, you call CQ and are working stations all over the country from the peace and quiet of...a hotel room hundreds of miles away from your QTH.

Introducing OMNI-VII, the world's first completely Ethernet-remoteable HF transceiver. Just plug OMNI-VII directly into your high-speed router in the ham shack (no computer required) and control it remotely over the Internet from a high-speed data connection. We even provide the software ready to use – at no additional charge. Easy!

Keeping in tradition with the long line of previous OMNI transceivers, OMNI-VII features everything you'd expect from a high-end HF transceiver. Superb receiver performance. 100 watts output on 160 through 6 meters with general coverage on receive. Our new 'Distributed Roofing Filter' architecture places narrow, mode appropriate filters in the 2nd I-F. Bright 320 x 240 color LCD backlit display. Optional broad range (10:1 SWR max.!) automatic antenna tuner. Three SO-239 antenna jacks – two for transceive and a third for a receive-only antenna.

**\$2550\*** or **\$2850\*** with autotuner.

Call us today at (800) 833-7373 for a complete info package or download the OMNI-VII brochure at [www.tentec.com](http://www.tentec.com).

**Ask about our 4-month finance plan.**

1185 Dolly Parton Pkwy., Sevierville, TN 37862 Sales: 800-833-7373 [www.tentec.com](http://www.tentec.com)

We accept Visa, MC, American Express and Discover. Office (865) 453-7172. FAX (865) 428-4483.

Sales: Mon-Fri 8:00-5:30 Eastern [sales@tentec.com](mailto:sales@tentec.com). Service: Mon-Fri 8:00-5:00 Eastern [service@tentec.com](mailto:service@tentec.com) (865) 428-0364.

\*Shipping is additional. TN residents add 9.5% sales tax

The Ten-Tec logo consists of a stylized 'T' shape with a red circle in the center, positioned above the text 'TEN-TEC' in a bold, sans-serif font.

RF MIXER 80987

This assembly contains the RF amplifier, transmit/receive mixer, first IF amplifier and the low level transmit amplifier. The selection of these amplifiers and the direction in which the signals flow is determined by the R and T voltages applied to pin diode switches D1 through D8. On receive Q1 and Q2 route the bandpassed receive signals through either an attenuator or RF preamp Q3. The signals are mixed with the LO to 9 MHz and amplified again in Q6. Q7 is a buffer for the noise blanker output and Q5 is the noise gate switching transistor. On transmit the 9.0 MHz TX IF is mixed with the LO, amplified by Q4 and applied to the bandpass filters.

The mixer balance controls are adjusted as follows:

- 1.) Tune in the receiver birdie at 21.320 MHz.
- 2.) Center the balance controls C18, C19 and R28.
- 3.) Terminate the antenna with 50 ohms and adjust in order R28, C19 and C18 to null the birdie.

Coil L6 and red trimmer capacitors C25 and C31 should be adjusted for maximum received signal strength.

---

TRANSISTOR	COLLECTOR		BASE		EMITTER	
	RECEIVE	TRANSMIT	RECEIVE	TRANSMIT	RECEIVE	TRANSMIT
Q1	0	0	.7	0	0	0
Q2	5.0	0	0	0	0	0
Q3	5.5	0	.9	0	.2	0
Q4	12.0	12.0	0	2.0	0	1.5
Q5	10.0	0	0	0	0	0
Q6	9.5	0	1.7	0	.9	0
Q7	13.0	13.0	5.0	5.0	5.0	5.0

---



## XTAL FILTER BOARD 81253

The XTAL filter board with its 9.000 MHz 8 pole filter sets the IF bandwidth on receive and removes the undesired sideband on transmit. T/R switching of the IF signals is done with D1 through D4.

TRANSISTOR	COLLECTOR		BASE		EMITTER	
	RECEIVE	TRANSMIT	RECEIVE	TRANSMIT	RECEIVE	TRANSMIT
Q1	9.5	0	1.6	0	.5	0

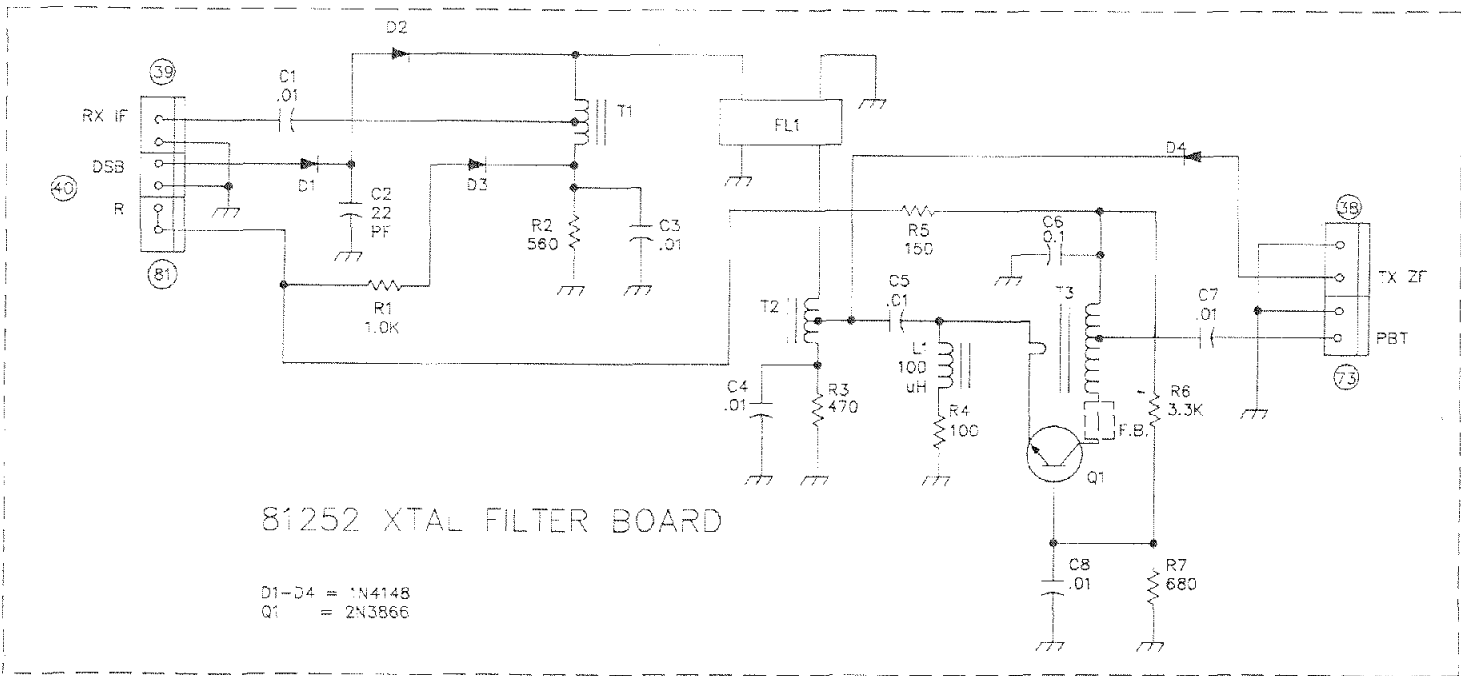

NOISE BLANKER 80977

The noise blanker board receives a sample of the 9.0 MHz receiver IF from the RF mixer board. Q1, U1 and U2 make up a 9.0 MHz AGC'd amplifier which detects noise pulses. Variable sensitivity is obtained by varying the emitter bias on Q2. For every noise pulse which exceeds the front panel N.B. LEVEL setting Q2 triggers one-shot U3B.

With the N.B. WIDTH control off pin 9 of U3 opens the noise gate on the RF mixer board for 400 mS. This blanking period is set by R24 and is sufficient for most types of ignition and line related noise. If the noise pulses are unusually long, for example like those caused by over-the-horizon, OTH, radar broadcasts, the blanking width can be extended for up to 5 mS with the N.B. WIDTH control. Since these long blanking pulses tend to create "holes" in the received signal U3A, R23 and D6 allow only one long pulse every 80 to 100 mS. Not accidentally this is also the repetition rate of the Russian "woodpecker" radar.

U1

PIN	RECEIVE	TRANSMIT
1	7.4	7.4
2	7.4	7.4
3	0	0
4	2.3	2.3
5	3.7	3.7
6	2.3	2.3
7	0	0
8	7.3	7.3

U2

PIN	RECEIVE	TRANSMIT
1	.2	.4
2	0	0
3	0	0
4	0	0
5	0	0
6	0	0
7	0	0
8	8.0	8.0

U3

PIN	RECEIVE	TRANSMIT
1	0	0
2	.6	.6
3	8.0	8.0
4	8.0	8.0
5	8.0	8.0
6	0	0
7	8.0	8.0
8	0	0
9	8.0	8.0
10	0	0
11	8.0	8.0
12	0	0
13	8.0	8.0
14	8.0	8.0
15	0	0
16	8.0	8.0

TRANSISTOR	COLLECTOR		BASE		EMITTER	
	RECEIVE	TRANSMIT	RECEIVE	TRANSMIT	RECEIVE	TRANSMIT
Q1	6.9	6.9	1.0	1.0	.3	.3
Q2	8.0	8.0	0	0	8.0	8.0
Q3	0	0	7.8	7.8	8.0	8.0
Q4	8.0	8.0	7.8	7.8	8.0	8.0



PBT, PASS BAND TUNING 80979

This board allows the operator to sweep one of the passband crystals across the passband of the receiver. The standard filter supplied with this board is an 8 pole 2.4 kHz unit. Optional 1.8, 0.5 and 0.25 kHz filters can be installed and selected electronically from the front panel. Coils L1, L2 and L3 are adjusted for maximum received signal strength. L4 sets the passband filter oscillator frequency. To adjust L4 center the front panel PBT control and while switching from SBN to SBR tune L4 such that the receiver background hiss is of the same pitch.

If the Model 288 1.8 kHz optional filter is to be installed, cut or remove the jumper located in the center of the 1.8 kHz socket.

TRANSISTOR	SOURCE		DRAIN		GATE 1		GATE 2	
	RECEIVE/TRANSMIT	RECEIVE/TRANSMIT	RECEIVE/TRANSMIT	RECEIVE/TRANSMIT	RECEIVE/TRANSMIT	RECEIVE/TRANSMIT	RECEIVE/TRANSMIT	RECEIVE/TRANSMIT
Q2	.27	.27	13.0	13.0	.25	.25	0	0

TRANSISTOR	COLLECTOR (drain)		BASE (gate)		EMITTER (source)	
	RECEIVE	TRANSMIT	RECEIVE	TRANSMIT	RECEIVE	TRANSMIT
Q1	13.0	12.95	.56	.56	1.55	1.55
Q3	5.7	5.7	2.6	2.6	2.1	2.1
Q4	9.5	9.4	4.8	4.8	5.7	5.7
Q5	9.5	9.4	5.7	5.7	5.2	5.2
Q6	8.0	8.0	4.0	4.0	6.0	6.0
Q7	8.0	8.0	6.0	6.0	5.1	5.1

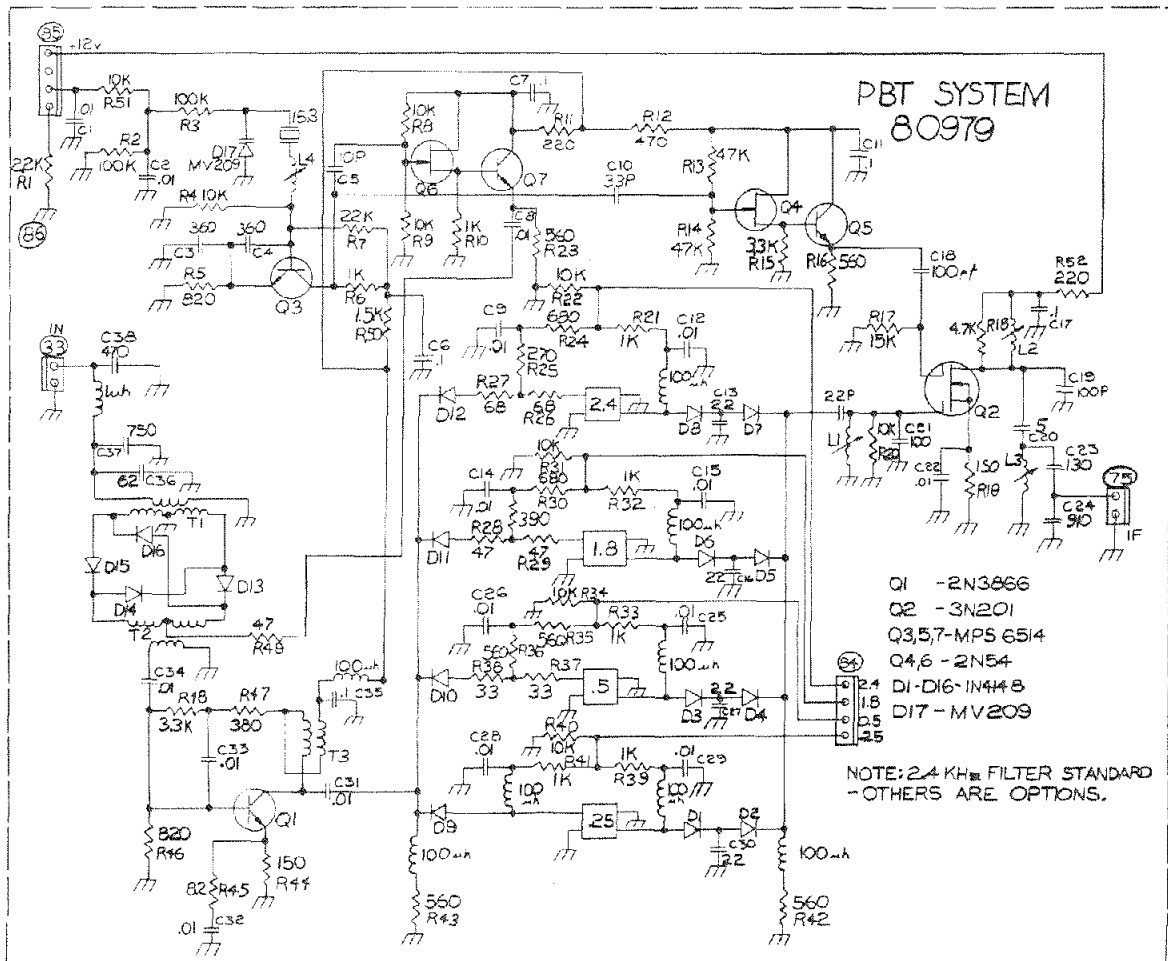



IF/AF BOARD 80984

This board handles most of the receive functions including RF gain control, notch and bandpass filters, AGC response and S-meter, audio amplification and CW sidetone. Coils L1 and L2 which peak the gain in the two 9.0 MHz IF amplifiers can be aligned using any low level received signal. The 21.320 MHz receiver spur is useful for this. The S-meter calibration however requires an accurate 14.000 MHz 50 uV signal. With the RF ATTN off and the 50 uV signal applied to the antenna jack adjust R59 for an S9 reading. Sidetone level and pitch are set by two controls centered just inside the access hole in the bottom cover.

U1

---

PIN	VOLTAGE	
	RECEIVE	TRANSMIT
1	4.1	4.1
2	4.1	4.1
3	4.1	4.1
4	4.1	4.1
5	4.1	4.1
6	4.1	4.1
7	0	0
8	4.1	4.1
9	4.0	4.0
10	4.1	4.1
11	8.0	8.0
12	4.1	4.1
13	4.1	4.1
14	4.1	4.1

---

L2

---

PIN	VOLTAGE	
	RECEIVE	TRANSMIT
1	4.0	4.0
2	4.0	4.0
3	4.0	4.0
4	0	0
5	0	0
6	0	0
7	0	0
8	8.0	8.0

---

U3

---

PIN	VOLTAGE	
	RECEIVE	TRANSMIT
1	2.2	2.2
2	4.1	4.1
3	4.0	4.0
4	4.0	4.0
5	4.0	4.0
6	2.2	2.2
7	0	0
8	4.2	4.2
9	1.0	1.0
10	4.2	4.2
11	8.0	8.0
12	4.0	4.0
13	4.0	4.0
14	4.0	4.0

---

U4

PIN	VOLTAGE	
	RECEIVE	TRANSMIT
1	2.4	2.4
2	4.1	4.1
3	4.0	4.0
4	4.0	4.0
5	4.0	4.0
6	2.5	2.5
7	0	0
8	4.0	4.0
9	4.0	4.0
10	4.0	4.0
11	8.0	8.0
12	4.5	4.5
13	1.0	1.0
14	4.5	4.5

U5

PIN	VOLTAGE	
	RECEIVE	TRANSMIT
1	6.2	6.2
2	0	0
3	0	0
4	0	0
5	0	0
6	0	0
7	0	0
8	6.2	6.2
9	0	0
10	0	0
11	0	0
12	0	0
13	0	0
14	12.5	12.5

TRANSISTOR	SOURCE		DRAIN		GATE 1		GATE 2	
	RECEIVE	TRANSMIT	RECEIVE	TRANSMIT	RECEIVE	TRANSMIT	RECEIVE	TRANSMIT
Q4	.6	.6	3.4	3.4	.1	.1	0	0

TRANSISTOR	EMITTER		BASE 1		BASE 2	
	RECEIVE	TRANSMIT	RECEIVE	TRANSMIT	RECEIVE	TRANSMIT
Q12	3.0	3.0	0	0	8.0	8.0

TRANSISTOR	COLLECTOR		BASE		EMITTER	
	RECEIVE	TRANSMIT	RECEIVE	TRANSMIT	RECEIVE	TRANSMIT
Q1	12.0	12.0	2.2	0	1.5	0
Q2	10.0	12.0	2.1	4.6	1.4	0
Q3	10.0	12.0	4.3	4.6	3.6	4.2
Q5	8.0	8.0	8.7	0	8.0	0
Q6	8.0	8.0	0	0	0	0
Q7	0	0	0	.7	0	0
Q8	12.0	12.0	.4	.4	0	0
Q9	0	0	12.0	12.0	13.0	13.0
Q10	0	0	0	.7	0	0
Q11	0	0	0	0	0	0

# 80984 IF/A BOARD

C1, D2, D3 - 1N5757  
 C4 - D11 - R4148  
 C1, D2, D3, S - MF5289J  
 C4 - 30201  
 C5 - 28, 011 - MF56514  
 Q6 - 2N5087  
 Q7, 0 - MFS1D1  
 Q7, 2 - 2E4879

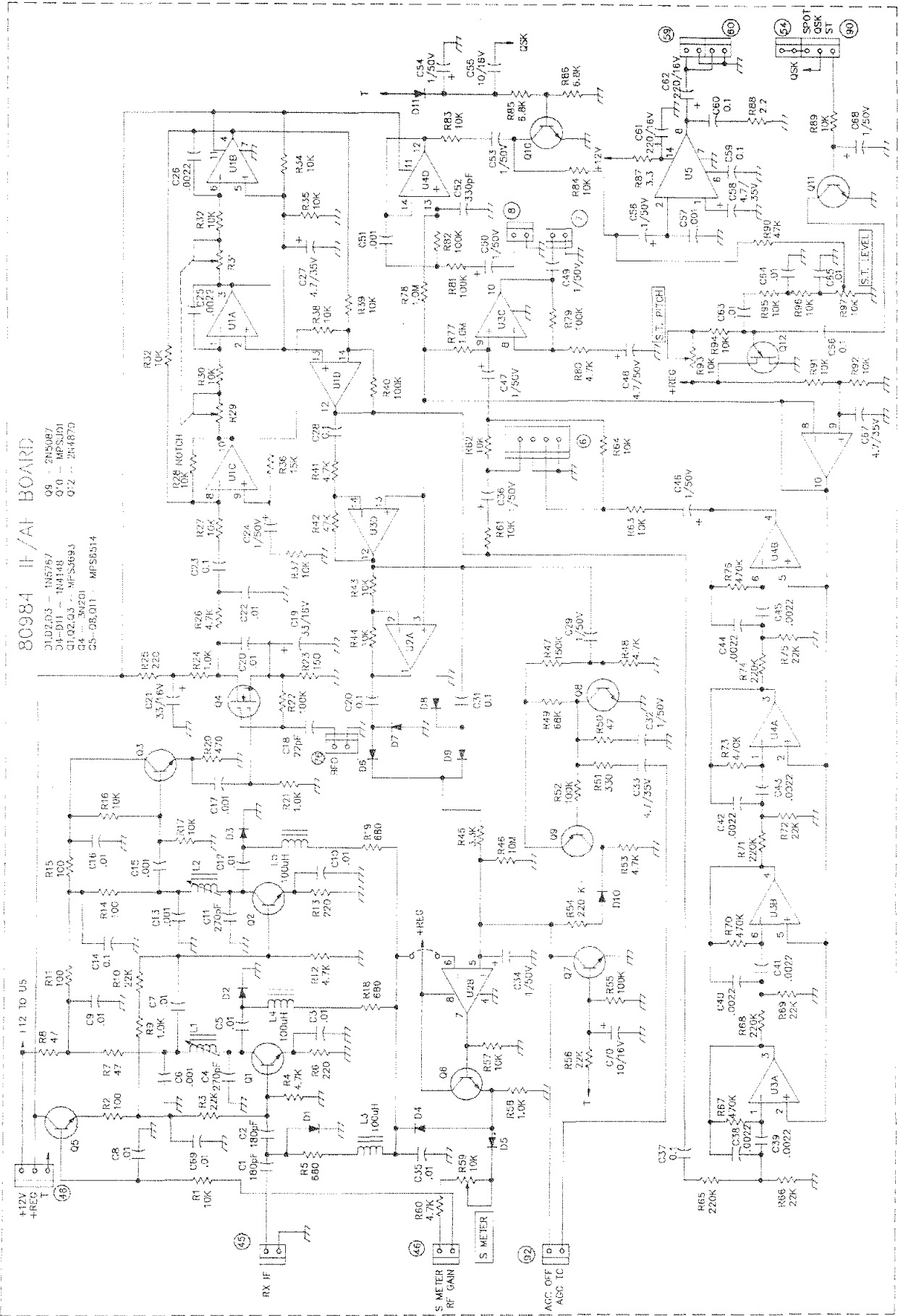



AUDIO\_PROCESSOR\_B1255

The audio processor amplifies and conditions microphone and patch/TU signals for the transmitter. Diodes D1 and D2 select either an amplified audio signal from U2A or a peak clipped and compressed version from U2B. Transistor Q1 is the compressor shunt element, D3 and D4 are the clipping elements. Also resident on the board is a CMOS oscillator for setting the built-in keyer speed. U1 receives +5 v from the counter/display assembly and returns a clock signal related to the KEYSPEED front panel control.

U1

---

PIN	RECEIVE	TRANSMIT
1	2.6	2.6
2	2.6	2.6
3	2.8	2.8
4	2.8	2.8
5	0	0
6	2.2	2.2
7	0	0
8	0	0
9	0	0
10	5.0	5.0
11	2.2	2.2
12	2.8	2.8
13	2.8	2.8
14	5.0	5.0

---

U2

---

PIN	RECEIVE	TRANSMIT
1	4.2	4.2
2	4.2	4.2
3	.9	.9
4	0	0
5	.9	.9
6	1.0	1.0
7	4.3	4.3
8	8.0	8.0

---

U3

---

PIN	RECEIVE	TRANSMIT
1	4.2	4.2
2	4.2	4.2
3	4.0	4.0
4	0	0
5	4.2	4.2
6	4.2	4.2
7	4.2	4.2
8	8.0	8.0

---



---

TRANSISTOR	COLLECTOR		BASE		EMITTER	
	RECEIVE	TRANSMIT	RECEIVE	TRANSMIT	RECEIVE	TRANSMIT
Q1	0	0	0	0	0	0
Q2	0	0	.7	.7	0	0
Q3	12	0	0	.7	0	0
Q4	0	12	.8	0	0	0

---



## DOUBLE SIDEBAND GENERATOR B0980

This assembly contains the carrier/BFO crystal oscillator Q1 and a balanced modulator U1 for double sideband generation. The exact frequency of the 9.0 MHz oscillator is determined by which combination of the three trimmer capacitors C1, C2 and C3 are placed in series with the crystal.

In the SBR mode only C1 is in series with the crystal and sets the oscillator frequency to 9.003 MHz. This positions the lower sideband of the modulator output just inside the passband of the XTAL FILTER board's 9.000 MHz crystal. In SB-N, C2 and C3 are switched in and pull the oscillator on down to 9.000 MHz. Now only the upper sideband passes through the XTAL FILTER board. In CW and LOCK modes C1 and C2 set the oscillator to 9.00750 MHz, while Q2 upsets the balance in the balanced modulator. The level from the modulator is a function of the voltage at pin 7 which comes from the DRIVE control.

**Carrier Oscillator Alignment:** Proper alignment of C1, C2 and C3 requires the use of a frequency counter. These capacitors should not be readjusted on general principles but only after it has been determined that the carrier is not where it should be on the passband curve, or the cw frequency is not 750 Hz up from the sideband normal carrier position. To make these adjustments proceed as follows:

- 1.) Connect the counter to the junction R3 and R4 in the emitter of Q1.
- 2.) Set the MODE switch to the SB-R position and DRIVE control fully counterclockwise. Adjust C1 for a frequency reading of 9.00300.
- 3.) Set the MODE switch to the LOCK position and adjust C2 so that the frequency is 9.000750.
- 4.) Set the MODE switch to the SB-N position and adjust capacitor C3 for a frequency of 9.00000.
- 5.) Return to step 2 and check the frequencies again because the adjustments interact to some extent.

**Carrier Null Adjustment:** With the MODE switch in SB-N, DRIVE control at full counterclockwise, and no microphone inserted in the microphone jack, alternately adjust R1 and R2 for minimum transmitted carrier, after adjusting T1 for maximum output signal.

U1

PIN	RECEIVE	TRANSMIT
1	5.5	2.0
2	0	.25
3	0	0
4	0	0
5	5.5	5.0
6	7.5	7.5
7	0	.7
8	8.0	8.0

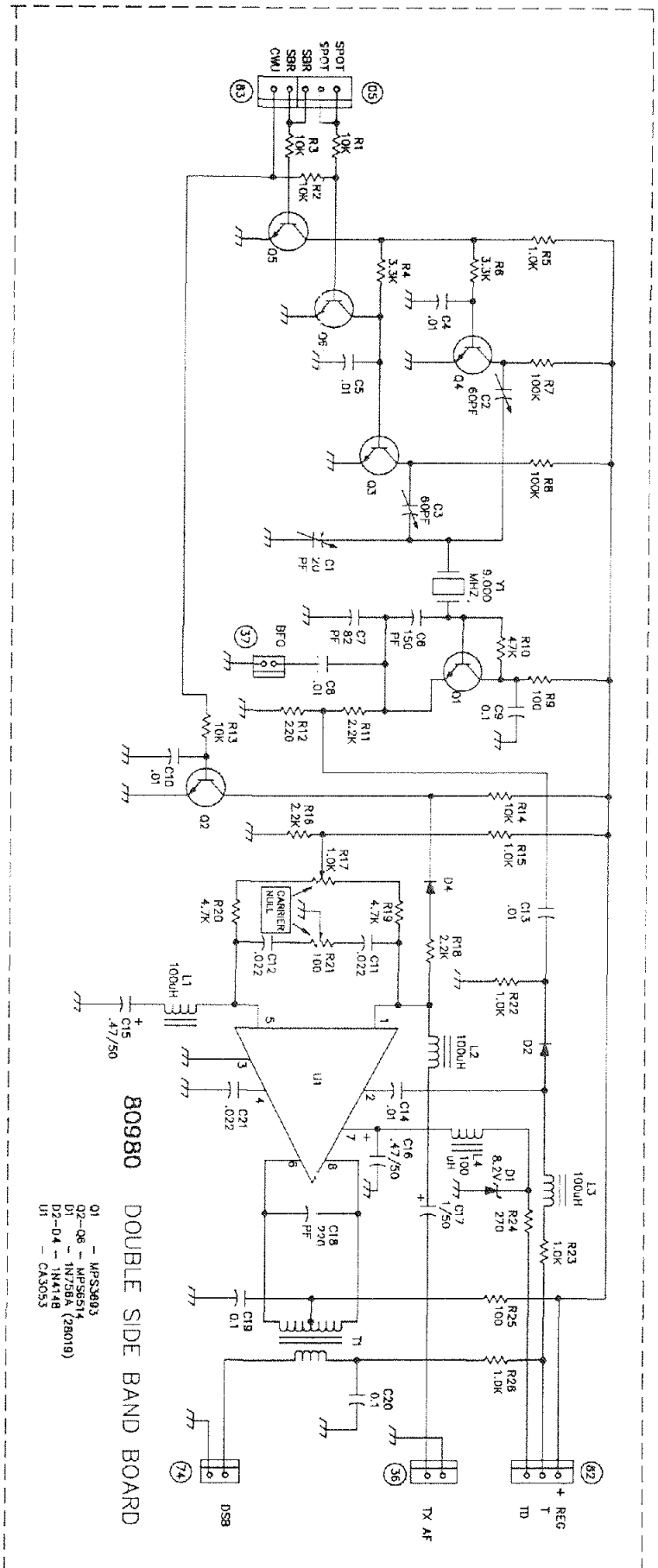

- 01 - MFS3693
- 02-06 - MFS9574
- D2-04 - 1N4004 (28019)
- 03 - 1N4004
- 04 - 1N4004
- 05 - 1N4004
- 06 - CA3055

**80980 DOUBLE SIDE BAND BOARD**

TRANSISTOR      COLLECTOR      BASE      EMITTER

RECEIVE      TRANSMIT      RECEIVE      TRANSMIT      RECEIVE      TRANSMIT

01	3.0	8.0	6.0	6.0	6.8
02	8.0	0	0	.8	0
03	0	0	.8	0	0
04	0	5.5	.8	0	0
05	5.5	5.5	0	0	0
06	.8	0	0	.8	0



It shouldn't feel like work.



## OMNI-VII. It's that simple.

So sit back in your chair and relax. The Omni-VII not only has top of the line receiver performance and everything else you need in a high-end transceiver -- it's also very easy to use. Spend your time on the air instead of reading the operator's manual. For complete information on the Omni-VII and our Amateur Radio product line, visit our website or call (800) 833-7373 for our current catalog.

**Proudly made in Sevierville, Tennessee USA**

**TEN-TEC**  
www.tentec.com

1185 Dolly Parton Pkwy., Sevierville, TN 37862. Sales: 800-833-7373 M-F 8:00-5:30 (Eastern Time) sales@tentec.com. Office: (865) 453-7172. FAX: (865) 428-4483. Service: (865) 428-0364 M-F 8:00-5:00 (Eastern Time), service@tentec.com. We accept Visa, MC, American Express and Discover.

# LOW LEVEL DRIVER - 81037

This assembly contains the transmit low level amplifier and the ALC circuit. Also, the signal into the bandpass filter is determined by the switching of PIN diodes D1 and D2. To adjust the action of the ALC LED indicator, place the MODE switch in the LOCK position and DRIVE control at full counterclockwise. Adjust R15 to a point just below where the LED begins to light. Using a wattmeter and dummy load, advance the DRIVE control until 100 watts is indicated on 14.05 MHz. Adjust the front panel ALC control for full clockwise rotation and then adjust R11 so that the LED is fully bright with 100 watts output.

TRANSISTOR	COIL (drain)		BASE (gate)		EMITTER (source)	
	RECEIVE	TRANSMIT	RECEIVE	TRANSMIT	RECEIVE	TRANSMIT
Q1	13.0	13.0	0	2.0	0	1.4
Q2	13.0	13.0	0	1.27	0	.6
Q4	13.0	13.0	0	4.2	0	4.5
Q5	0	4.5	.75	0	0	0
Q6	0	0	5.4	5.4	3.5	5.1
Q7	3.8	5.1	3.2	4.4	3.5	5.1
Q8	0	.25	.61	.54	0	0
Q9	2.5	2.6	0	0	13.0	13.0

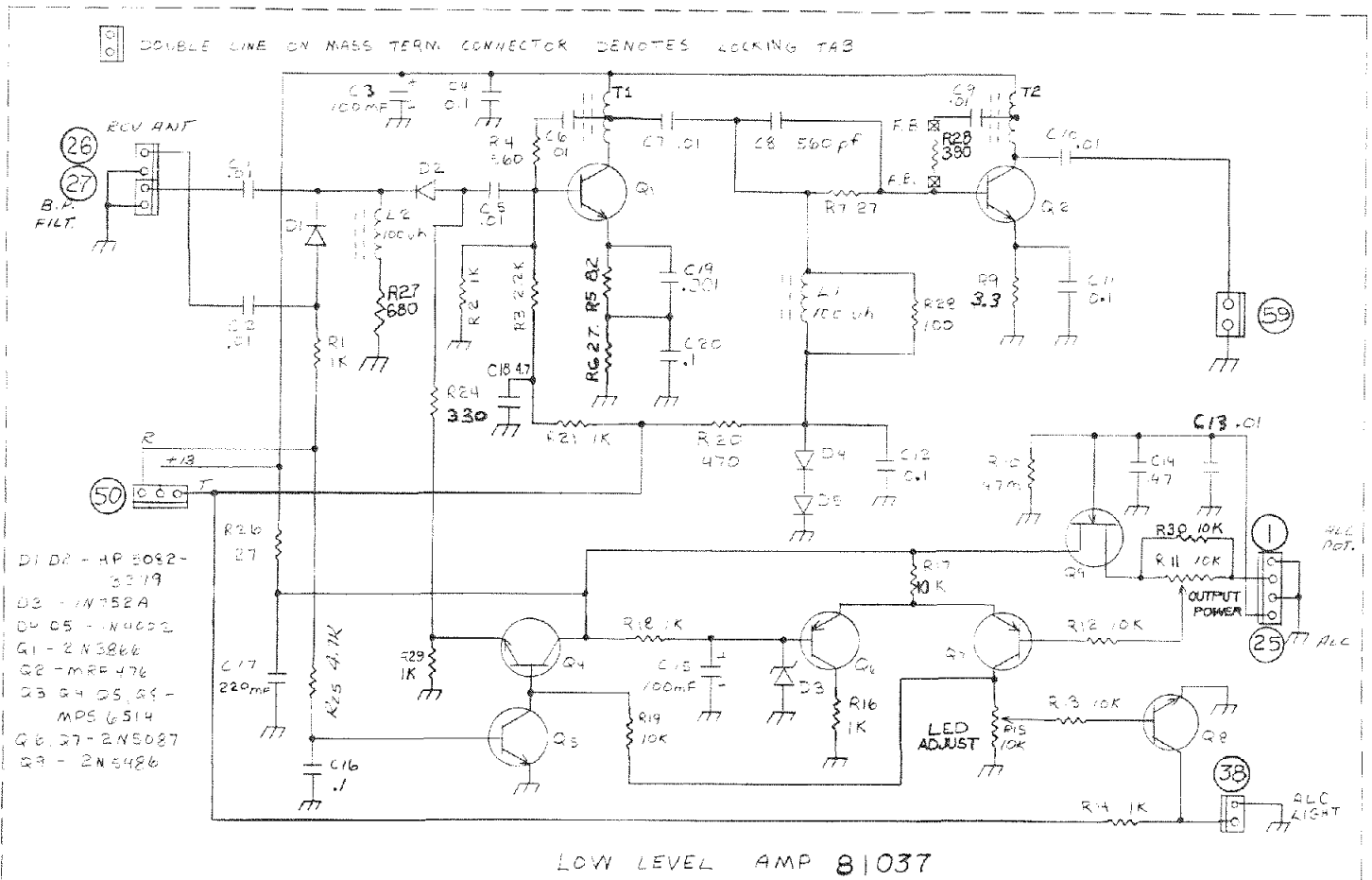

## FINAL AMP ASSEMBLY - 80565

The high power rf amplifier and its push-pull drive stage are housed in a metal box which is an integral part of the heat sink assembly. The unit is attached to the back panel with four screws.

Q1 and Q2 constitute a Class AB linear push-pull driver stage of wide band design. Impedance matching into and out of this stage is by means of transformers T1 and T2. Bias is applied whenever "T" voltage is applied to the terminal so marked, and quiescent current in the collector circuit is adjusted to a value of between 4 and 8 mA with potentiometer R11. Access to this control is by means of the small hole in the brass box as shown on Figure 1 of this section. To adjust bias, unsolder the small jumper red wire connecting the second small feed through terminal to the large +12 volt lug. Insert a dc milliammeter between the two, set DRIVE control fully CCW and MODE switch to LOCK position. If driver collector current is not between the recommended limits, readjust trimpot (clockwise to increase current) by rotating the trimpot plastic serrated knob through the shield box hole with the aid of a small awl type probe.

Power amplifier transistors Q3 and Q4 are also in a Class AB push-pull arrangement. Bias is applied to the bases in a shunt feed system through L2 and L3. Bias is fed to this stage from a regulated and controlled supply on the cover of the amplifier box.

Bias for both stages is temperature compensated to maintain a relatively constant operating point by mounting the bias diodes in direct contact with the heat sink. D1 controls the driver stage and D2 the output stage.

Final amplifier bias is adjusted by R23. To adjust bias, place a DC ammeter in the +13 V dc supply lead. Load into a dummy load, set MODE switch to LOCK position and Drive control fully counterclockwise. Note the current reading and then slowly rotate R23 in the direction that decreases the current reading. After determining which direction decreases current, set the control fully in this direction. This will cut off the final transistors. Note the current reading and then advance R23 to that the reading increases by 1/2 ampere - no more. This value should be approximately 1-1/2 amperes total. Too low a bias setting will cause distorted audio in sideband due to amplifier operating class C. Too high a quiescent current will increase power dissipation in the output transistors.

# RF POWER AMP 80565

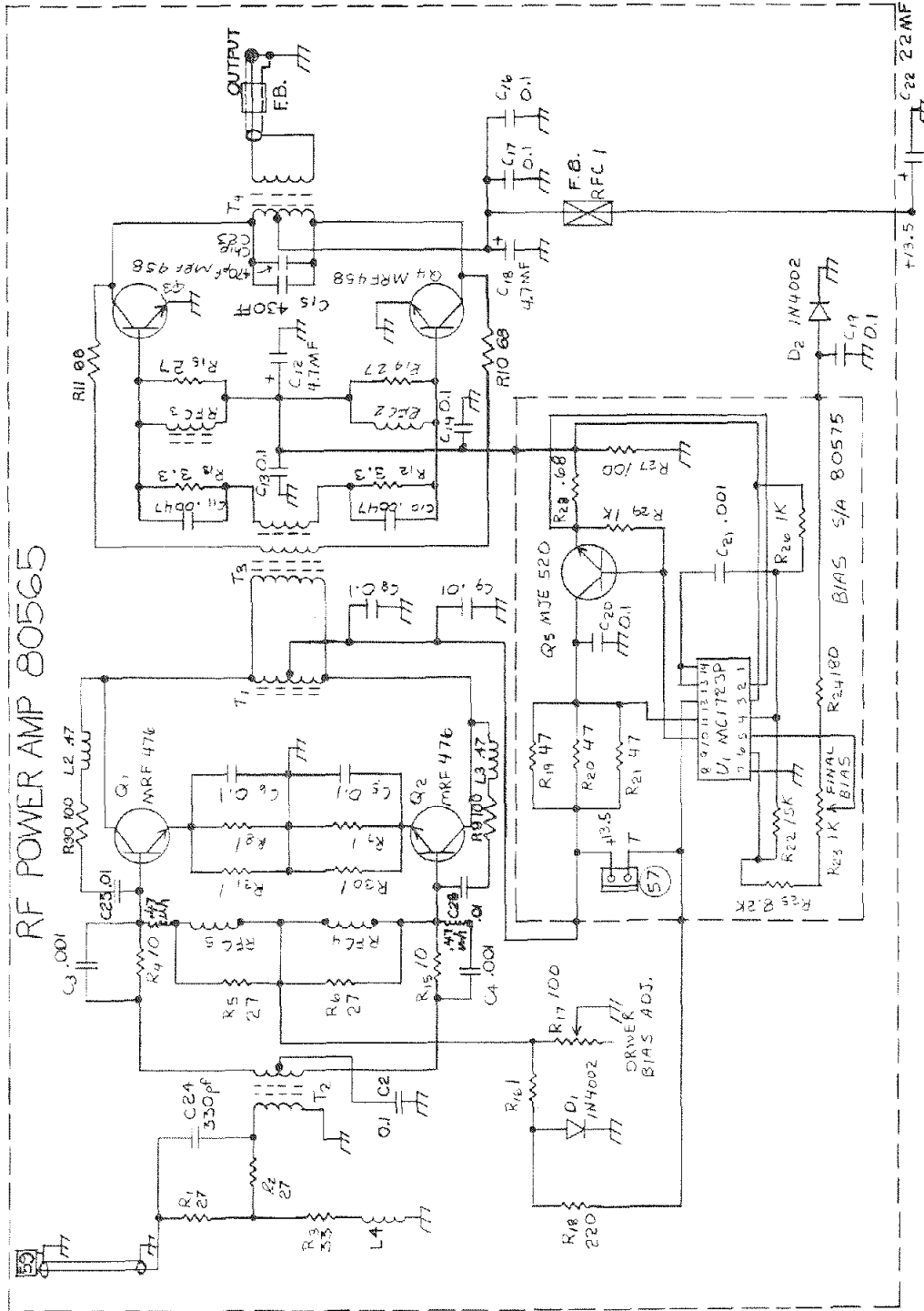

# BANDPASS FILTER - 80976

This assembly contains individual bandpass filters for each band. They consist of critically or over-coupled tuned circuits, 3 poles on each band except 10 and 15 meters. Because the tuning of these circuits is critical and they are used both when receiving and transmitting, these resonant circuits are best aligned using a sweep oscillator system. Realignment is seldom necessary except when a tuned circuit component has been replaced. Since all of the component are passive, no voltage measurements are required.

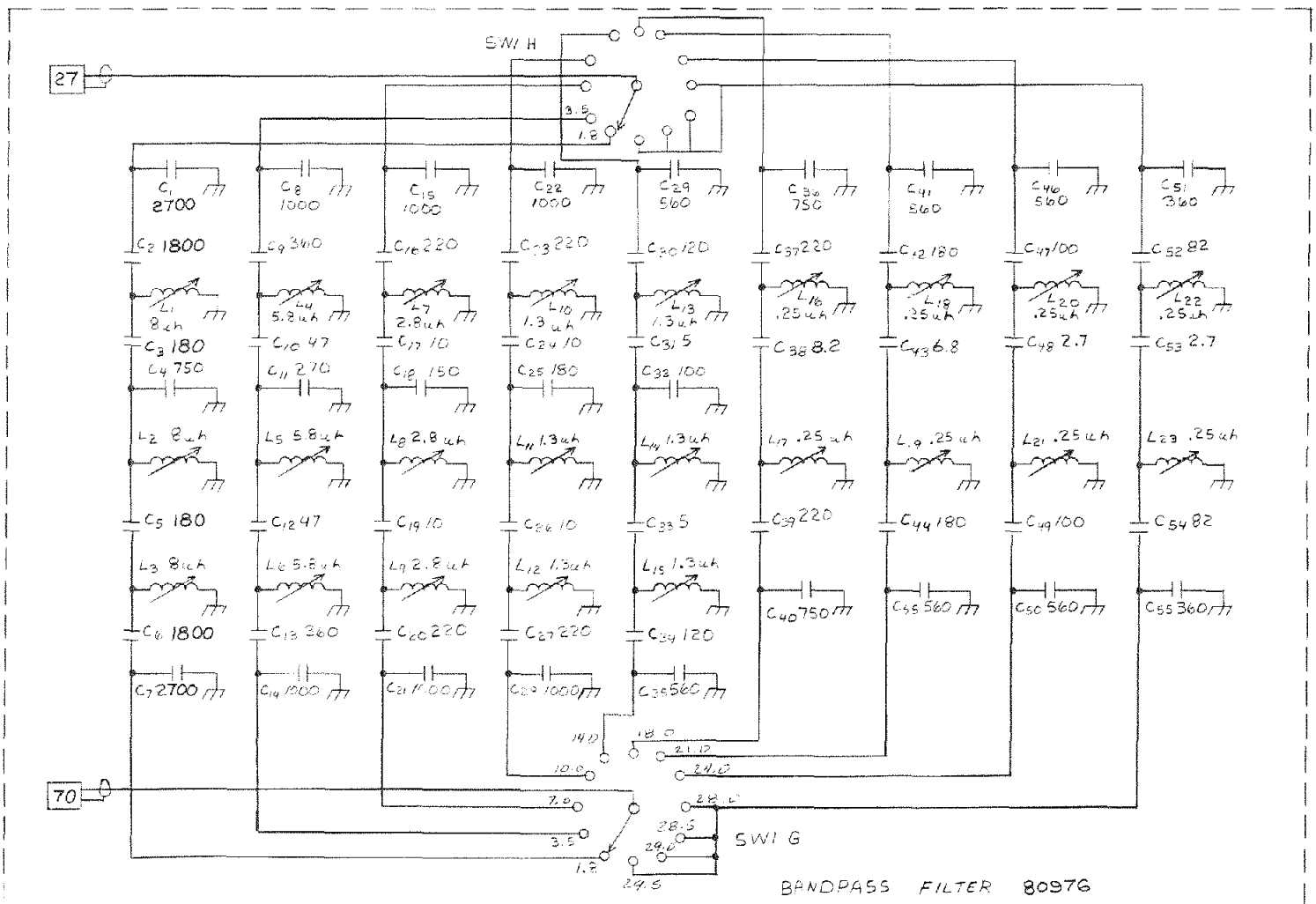

## LOW PASS FILTER - 80969

This assembly contains the low pass output filters and the electronic TR switch. The output signal from the final rf amplifier contains harmonic components above the desired level. To attenuate these harmonics to a suitable level, the signal is passed through a 5 pole low pass filter before being radiated. The proper filter is selected by the bandswitch. The final amplifier is disconnected from the antenna circuit during receive by relay K1. Switching of the receive antenna is performed by switch Q1 and diodes D1 and D2. This allows extremely fast switching of the antenna and permits full break-in operation on cw. PIN diodes D1 and D2 connect the antenna to the receiver input when receiving, and are back biased by a voltage rectified by D3 through D6 on transmit. There are no user adjustments on this board.

## SWR BOARD - 80970

This board contains the SWR, power, and ALC sensing circuits. The bridge balance control, C1, is adjusted through an access hole on the right side panel. The SWR meter is calibrated by placing an additional 50 ohm load in parallel with an existing 50 ohm load and adjusting R1 for an SWR meter reading of 2:1. With the meter switch in the forward power setting, adjust R2 to agree with an external calibrated wattmeter.

## SWR/LPF 80969 - 80970

TRANSISTOR	COLLECTOR		BASE		EMITTER	
	RECEIVE	TRANSMIT	RECEIVE	TRANSMIT	RECEIVE	TRANSMIT
Q1 2N6517	7.80	-.15	7.96	.35	8.71	.72
Q2 2N6514	.05	0	0	.79	0	0
Q3 MP68097	0	10.5	0	0	0	0

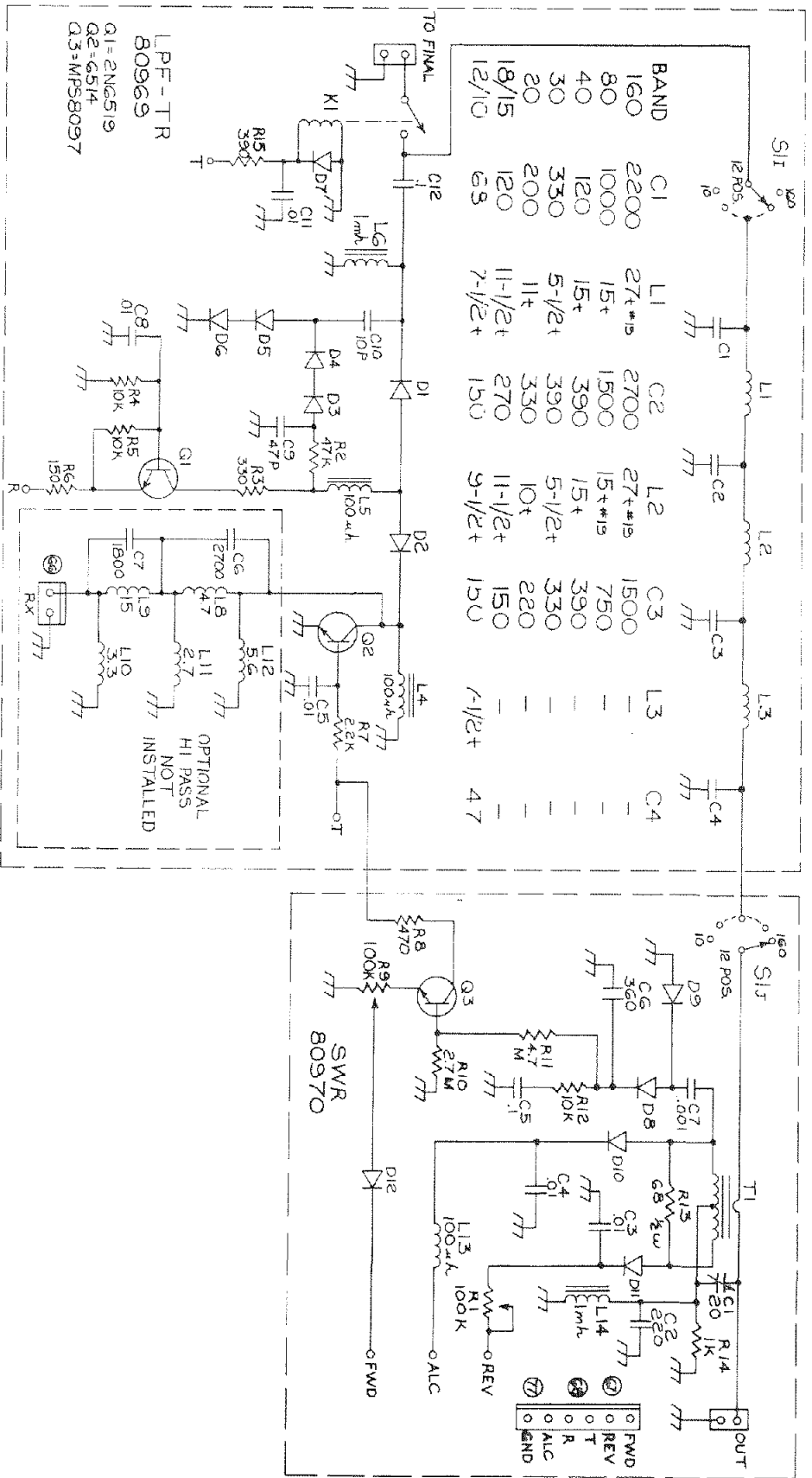

## DIGITAL READOUT

The frequency counter and digital display section of the CORSAIR II consists of two interconnected printed circuit assemblies located in an aluminum enclosure which is secured to the front subpanel. The large scale integrated circuit, display interface circuitry, a 10-1 prescaler, and a 5 volt regulator are mounted on the counter logic board 80973. The remaining circuits for the counter timebase and pre-amp are mounted on the pre-amp board 80974.

This portion of the transceiver is highly complex and contains MOS and CMOS integrated circuits that are susceptible to damage from static burnout if improperly handled. There are no user servicable components inside.

The counter counts the actual VFO frequency being applied to the first mixer, and assumes that the BFO frequency is either 9 or 9.003 MHz. This is the case for sideband normal and sideband reverse, respectively. Since the VFO signal is either 9 MHz above or 9 MHz below the output frequency, the counter must understand which band is being used and make the appropriate arithmetic correction. If the frequency of the BFO is properly set, and the counter is properly preset, the resulting frequency displayed will be within  $\pm 100$  Hz of the actual frequency after proper adjustment of the counter timebase. The counter preset can be checked by removing the VFO jumper and comparing the preset information with that in the table below.

COUNTER PRESETS (VFO jumper removed)

BAND	MODE	DISPLAY
1.8, 3.5, 7.0	SBN	-1.000 0
	SBR	-0.997 0
10, 18	SBN	91.000 0
	SBR	90.997 0
14, 21, 24.5 28-30	SBN	09.000 0
	SBR	09.003 0

To adjust the counter timebase, turn the bandswitch to 10 MHz and adjust the WWV at 10.0000 MHz. Tune the signal for maximum voice clarity during the time announcement. After adjusting the tuning, if the frequency display in SB-N mode is not 10 MHz exactly, then adjust capacitor C1 through the access hole on the left side of the counter enclosure to adjust the display so it reads 10.000.0 MHz.



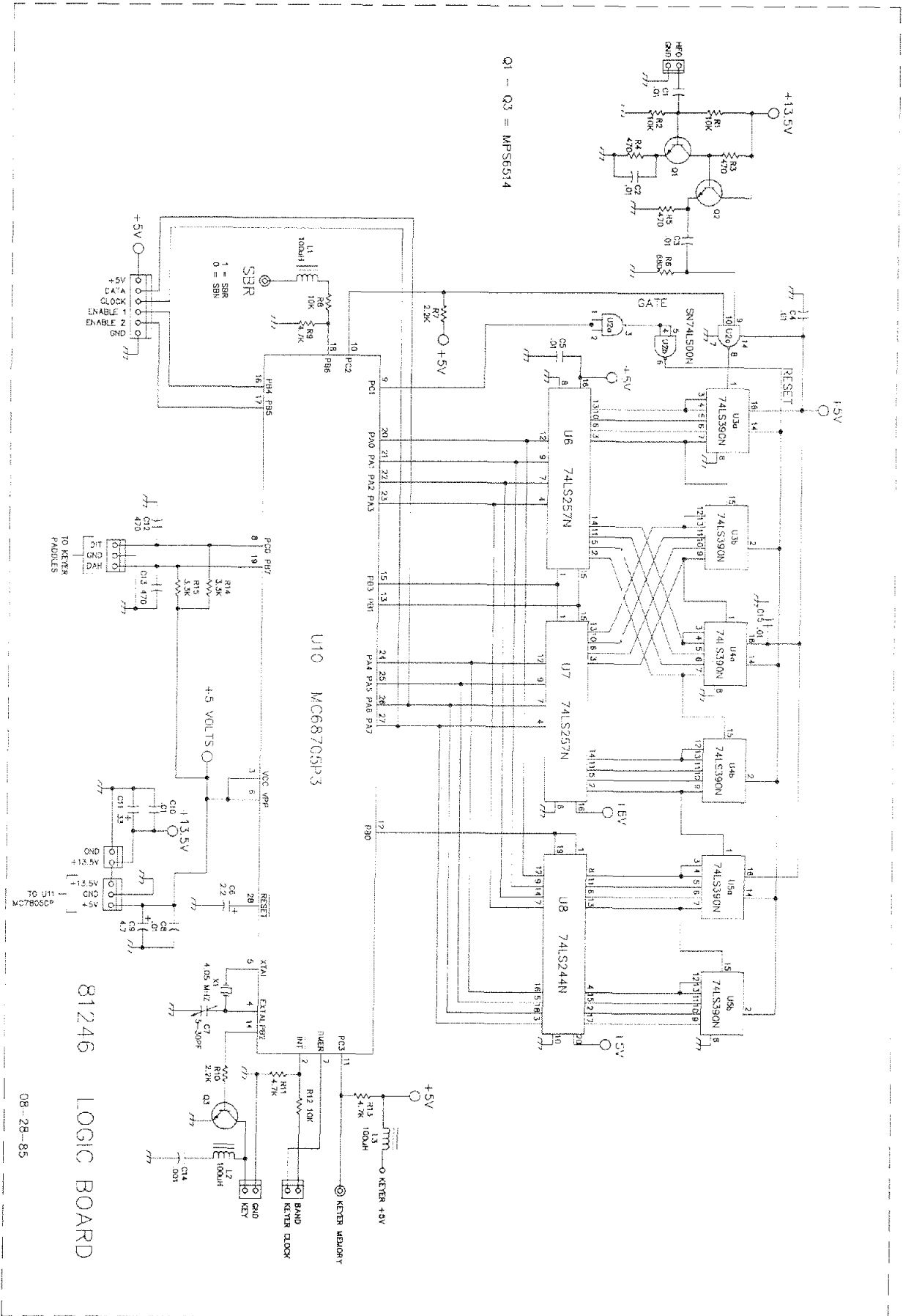

Q1 - Q3 = MPS6514

81246 LOGIC BOARD

08-28-85

08-28-85

## CONTROL BOARD - 80978

This assembly contains a set of synchronous transistor switches for controlling the "T" and "R" voltages that switch the unit from transmit to receive mode. It also contains an integrated circuit voltage regulator which powers the frequency and voltage sensitive circuits in the VFO, sideband generator, product detector, and offset control circuits.

Transistors Q1 through Q5 and Q11 generate the T and R voltages. Transistor Q9 and IC U1 are the voltage regulator. Transistors Q13 and Q14 plus diodes D3 and D4 perform the offset tuning switch functions.

Control relay K1 is operated by T voltage and provides external control of accessory equipment such as an external linear amplifier. In the cw mode only, the delay of this relay is controlled by the setting of R10. In esb mode the "hang" of this relay is determined by the VOX delay control on the front panel.

The offset tuning zero adjustment is accomplished by centering the offset tuning control and noting the frequency display. Turn the offset select switch to off and adjust the potentiometer R12 so the display returns to its former state. Final adjustment of this control can be made by alternately switching from OFF to MIN and back again while adjusting R12 for no change in received signal pitch.

TRANSISTOR	COLLECTOR		BASE		EMITTER	
	RECEIVE	TRANSMIT	RECEIVE	TRANSMIT	RECEIVE	TRANSMIT
Q1	0	8.0	7.9	7.7	8.0	8.0
Q2	.2	13.0	.7	0	0	0
Q3	0	0	0	12.5	0	1.0
Q4	13.0	13.0	0	12.5	0	1.0
Q5	13.0	0	0	.75	0	0
Q6	0	0	13.0	0	12.0	0
Q7	13.0	13.0	13.0	0	12.5	0
Q8	.2	12.5	0	0	0	0
Q9	8.4	8.4	12.5	12.5	13.0	13.0
Q10	13.0	1.8	0	.8	0	0
Q11	2.0	0	0	.75	0	0
Q12	0	8.5	0	0	0	0
Q13	4.0	4.0	0	0	0	0
Q14	0	0	.65	.65	0	0
Q15	0	0	0	.75	0	0

U1

PIN	VOLTAGE	
	RECEIVE	TRANSMIT
1	0	0
2	8.5	8.5
3	8.2	8.2
4	7.2	7.2
5	7.2	7.2
6	7.2	7.2
7	0	0
8	0	0
9	1.65	1.65
10	8.4	8.4
11	13.0	13.0
12	13.0	13.0
13	9.8	9.8
14	0	0

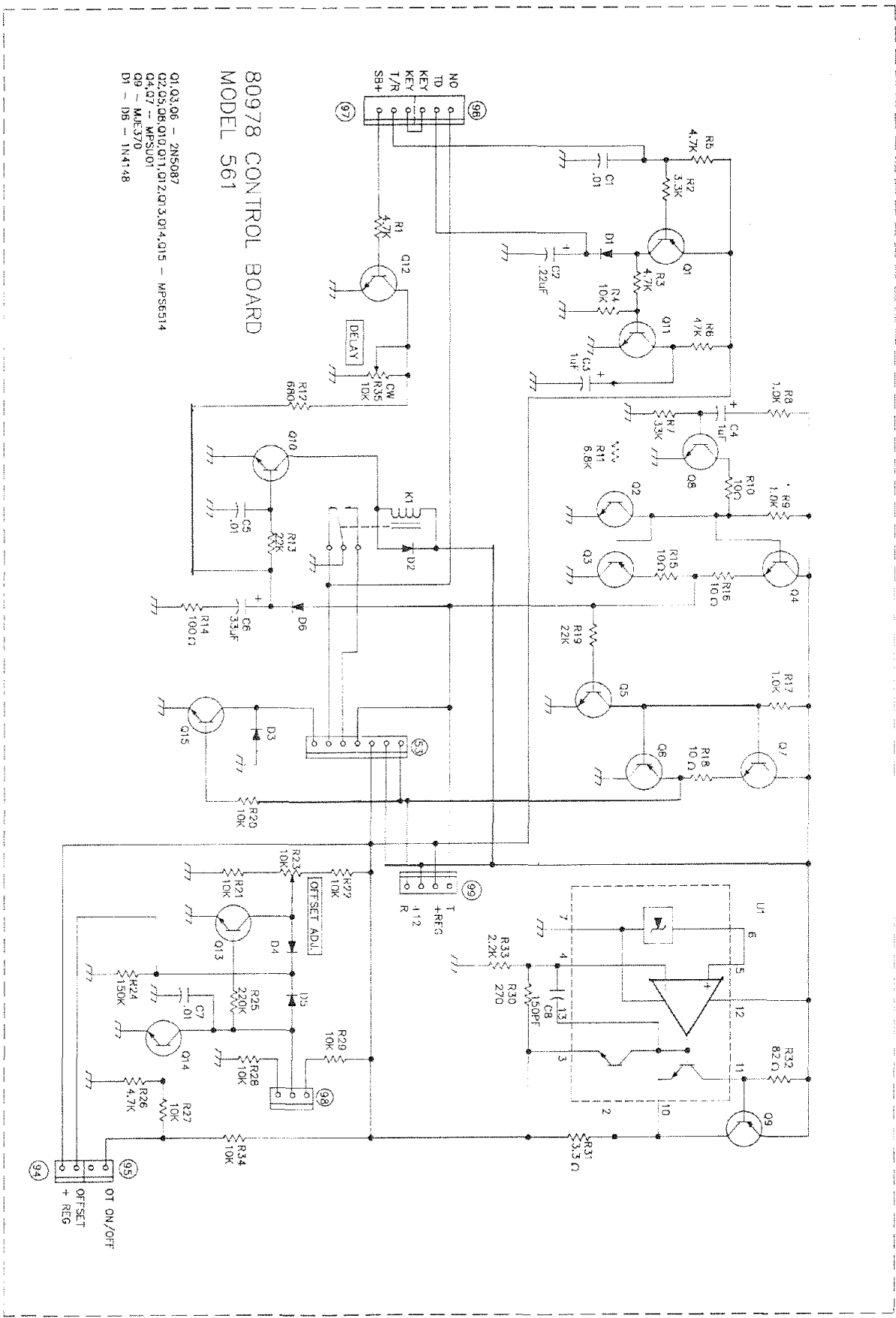

80978 CONTROL BOARD  
MODEL 561

Q1,Q3,Q6 - 2N5087  
Q2,Q5,Q8,Q10,Q11,Q12,Q13,Q14,Q15 - MFS5614  
Q4,Q7 - MFS370  
Q9 - MJE370  
D1 - D6 - 1N4148



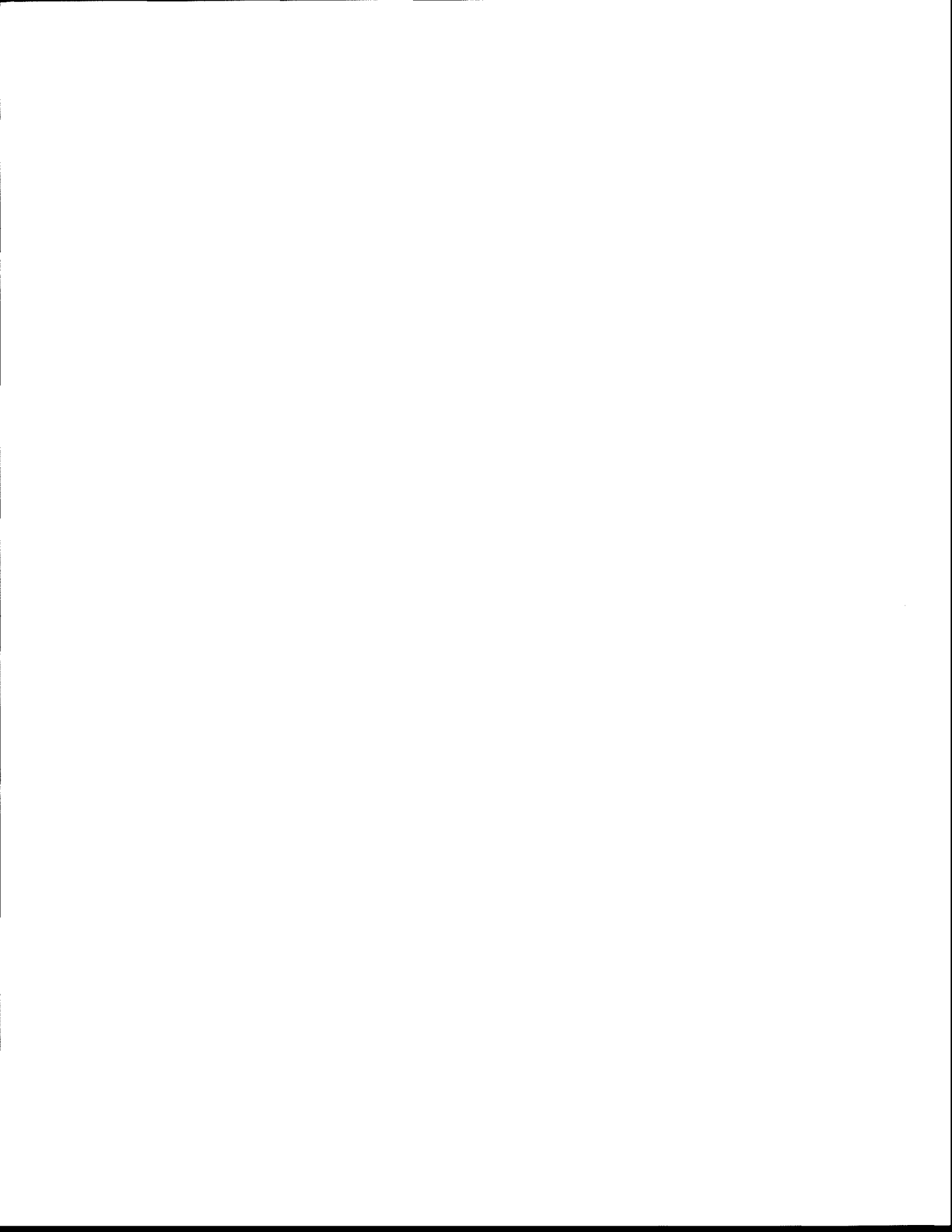

Ten-Tec, Inc.  
1185 Dolly Parton Parkway  
Sevierville, TN 37862  
Repair Service: (865) 428-0364

#### LIMITED WARRANTY AND SERVICE POLICY, U.S.A. AND CANADA

Ten-Tec, Inc., warrants this product to be free from defects in material and workmanship for a period of one (1) year from the date of purchase, under these conditions:

1. THIS WARRANTY APPLIES ONLY TO THE ORIGINAL OWNER. It is important that the warranty registration card be sent to us promptly.
2. READ THE MANUAL THOROUGHLY. This warranty does not cover damage resulting from improper operation. Developing a thorough understanding of this equipment is your responsibility.
3. IF TROUBLE DEVELOPS we recommend you contact our customer service group direct at the address or phone number shown above. It has been our experience that factory direct service is expeditious and usually results in less down-time on the equipment. Some overseas dealers do offer warranty service and, of course, have our complete support.
4. EQUIPMENT RETURNED TO THE FACTORY must be properly packaged, preferably in the original shipping carton(s). You pay the freight to us and we prepay surface freight back to you. Canadian customers must have proper customs documentation sent with incoming repair equipment. Duties or fees charged due to improper documenting are the responsibility of the owner of the equipment.
5. EXCLUSIONS. This warranty does not cover damage resulting from misuse, lightning, excess voltages, polarity errors or damage resulting from modifications not recommended or approved by Ten-Tec. In the event of transportation damage, a claim must be filed with the carrier. Under no circumstances is Ten-Tec liable for consequential damages to persons or property caused by the use of this equipment.
6. TEN-TEC RESERVES the right to make design changes without any obligation to modify equipment previously manufactured, or to notify owners of changes to existing equipment.
7. THIS WARRANTY is given in lieu of any other warranty, expressed or implied.

#### SERVICE OUTSIDE OF THE U.S.A. OR CANADA

Many of our international dealers provide warranty service on the equipment they sell. Many of them also provide out of warranty service on all equipment whether they sold it or not. If your dealer does not provide service or is not conveniently located, follow the procedure outlined above. Equipment returned to us will be given the same attention as domestic customers but roundtrip freight expense, customs and broker fees will be paid by you.

Part no. 74244

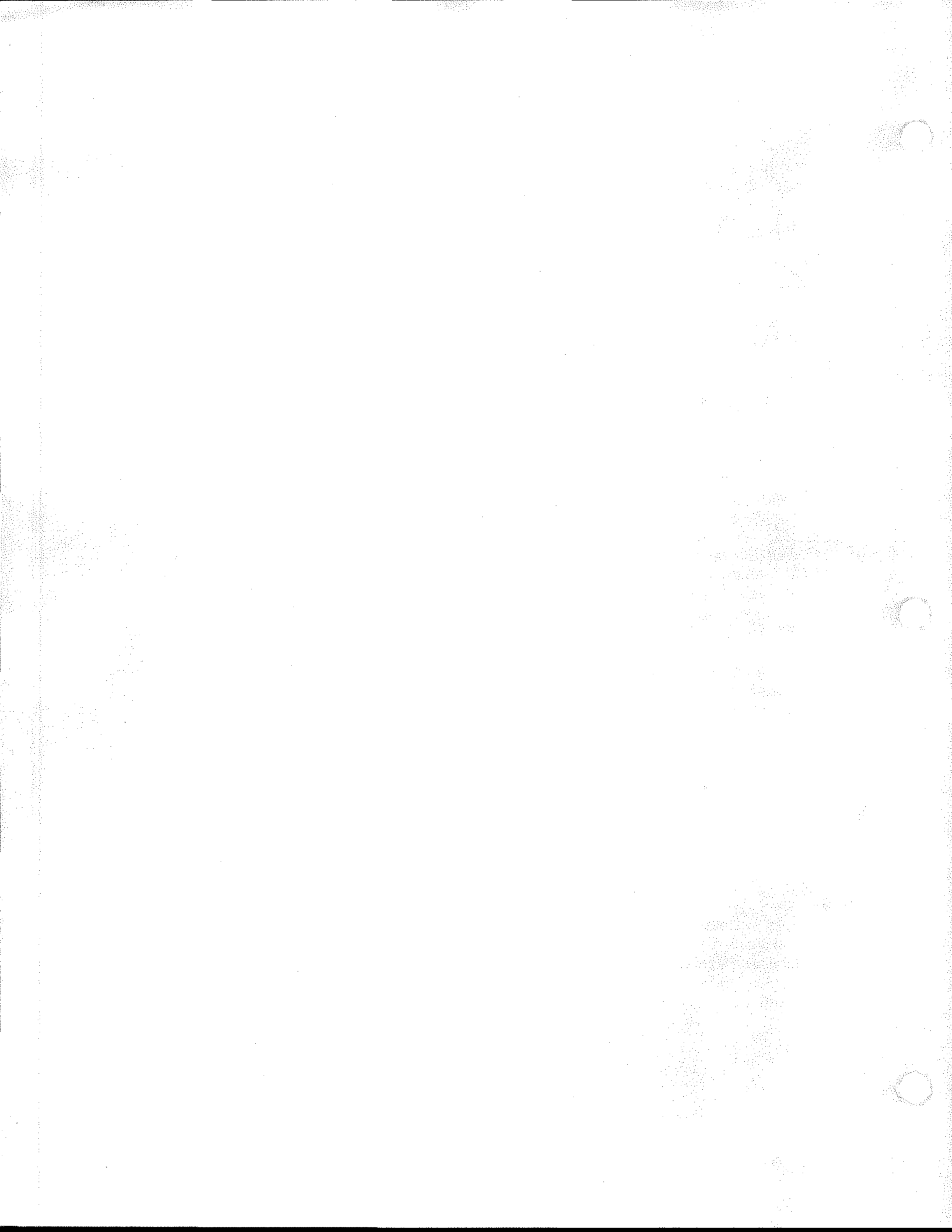

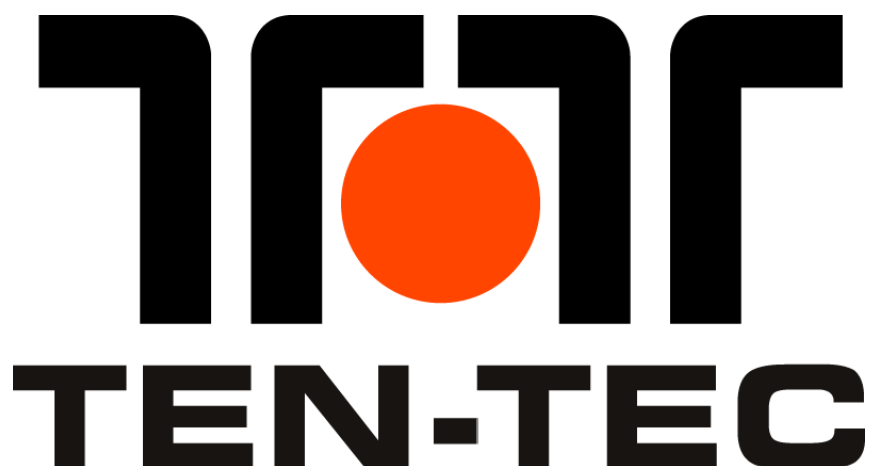

**This obsolete manual file is provided as a courtesy to you by Ten-Tec, Inc.**

**Ten-Tec's service department can repair and service virtually everything we have built going back to our first transceivers in the late 1960's. It is our ability to continue offering service on these rigs that has led to their re-sale value remaining high and has made a major contribution to our legendary service reputation.**

**Printed and bound copies of all manuals are available for purchase through our service department if you would prefer not to use this copy as your transceiver manual.**

**We can repair or service your Ten-Tec equipment at our facility in Sevierville, TN. We also offer support via telephone for all products via during usual business hours of 8 a.m. to 5 p.m. USA Eastern time, Monday through Friday. We have a large supply of parts for obsolete products. Repairing a transceiver or amplifier yourself? Contact us for parts pricing information.**

**Service department direct line: (865) 428-0364  
Ten-Tec office line: (865) 453-7172  
Service department email: [service@tentec.com](mailto:service@tentec.com)  
Address: 1185 Dolly Parton Parkway, Sevierville, TN 37862 USA**

**We have found it is most effective for us to help you troubleshoot or repair equipment with a consultation via telephone rather than by email.**

**Suggested contact methods are:**

**Troubleshooting or repairing equipment – call (865) 428-0364  
Other inquiries – call (865) 428-0364 or email [service@tentec.com](mailto:service@tentec.com)**

**THANK YOU AND 73 FROM ALL OF US AT TEN-TEC**