

This obsolete manual file is provided as a courtesy to you by Ten-Tec, Inc.

Ten-Tec's service department can repair and service virtually everything we have built going back to our first transceivers in the late 1960's. It is our ability to continue offering service on these rigs that has led to their re-sale value remaining high and has made a major contribution to our legendary service reputation.

Printed and bound copies of all manuals are available for purchase through our service department if you would prefer not to use this copy as your transceiver manual.

We can repair or service your Ten-Tec equipment at our facility in Sevierville, TN. We also offer support via telephone for all products via during usual business hours of 8 a.m. to 5 p.m. USA Eastern time, Monday through Friday. We have a large supply of parts for obsolete products. Repairing a transceiver or amplifier yourself? Contact us for parts pricing information.

**Service department direct line: (865) 428-0364
Ten-Tec office line: (865) 453-7172
Service department email: service@tentec.com
Address: 1185 Dolly Parton Parkway, Sevierville, TN 37862 USA**

We have found it is most effective for us to help you troubleshoot or repair equipment with a consultation via telephone rather than by email.

Suggested contact methods are:

**Troubleshooting or repairing equipment – call (865) 428-0364
Other inquiries – call (865) 428-0364 or email service@tentec.com**

THANK YOU AND 73 FROM ALL OF US AT TEN-TEC

TEN-TEC

**OPERATOR'S
MANUAL**

PARAGON II

MODEL 586

HF TRANSCEIVER

TABLE OF CONTENTS

<u>PARAGRAPH</u>	<u>PAGE</u>
TABLE OF CONTENTS	i
LIST OF ILLUSTRATIONS	vi
SPECIFICATIONS	viii
UNPACKING.....	xi
INTRODUCTION.....	xii
1. SETTING UP	
1-1 POWER SUPPLY	1-1
1-2 ANTENNA	1-1
1-3 MICROPHONE	1-2
1-4 CW.....	1-2
1-5 STATION GROUND.....	1-2
1-6 OTHER ACCESSORY EQUIPMENT	1-2
1-7 TEN-TEC ACCESSORIES FOR PARAGON II	1-3
1-8 INSTALLING INTERNAL OPTIONS	1-3
1-8.1 REMOVAL OF TOP AND BOTTOM COVERS	1-3
1-8.2 OPTIONAL CRYSTAL FILTERS	1-3
1-8.3 OPTIONAL VOICE SYNTHESIZER, MODEL 257	1-3
1-8.4 OPTIONAL ALC ANNUNCIATOR, MODEL 259	1-4
1-8.5 INTERFACING WITH OTHER TEN-TEC EQUIPMENT	1-4
2. GETTING STARTED	
2-1 ABOUT THE STYLE AND CONVENTIONS OF THIS INSTRUCTION MANUAL	2-1
2-2 QUICK REFERENCE TO KEYBOARD FUNCTIONS	2-1
2-3 GLOSSARY OF EXTENDED KEYBOARD FEATURES AND FUNCTIONS	2-3
2-3.1 AUTOMATIC MEMORY TUNE	2-3
2-3.2 BAND REGISTERS	2-3
2-3.3 FSK MODE	2-3
2-3.4 MATRIX MODE	2-3
2-3.5 SCRATCH PAD MEMORY	2-3
2-3.6 CLEAR ALL MEMORIES	2-3
2-4 FIRST POWER-UP (RECEIVE ONLY)	2-3
2-5 FRONT PANEL ORIENTATION	2-4
2-6 INITIAL TRANSMIT TEST	2-4
2-7.1 SSB OPERATION	2-4
2-7.2 CW OPERATION	2-4

TABLE OF CONTENTS (continued)

<u>PARAGRAPH</u>	<u>PAGE</u>
2-7.3 AM OPERATION.....	2-4
2-7.4 FM OPERATION.....	2-4
2-7.5 DIGITAL, ATV AND OTHER MODES.....	2-5
2-8 UNDERSTANDING THE MICROPROCESSOR.....	2-5
2-8.1 RESET PROCEDURE.....	2-5
2-8.2 MEMORY BACKUP.....	2-5
2-9 USING MEMORY FEATURES: A BRIEF TUTORIAL.....	2-5
2-10 SUMMARY.....	2-6
3. DETAILED OPERATING INSTRUCTIONS	
3-1.1 CHANGING FREQUENCY.....	3-1
3-1.2 DIRECT FREQUENCY ENTRY: BASIC USE AND SHORTCUTS.....	3-1
3-1.3 MODE SELECT KEYS.....	3-1
3-1.4 TUNE.....	3-1
3-1.5 FSK OPERATION.....	3-2
3-1.6 USING THE FAST TUNING FUNCTION.....	3-2
3-1.7 ADJUSTING MAIN TUNING KNOB.....	3-3
3-2.1 DIGITAL COMMUNICATIONS BASICS.....	3-3
3-2.2 USING PARAGON II IN DIGITAL COMMUNICATIONS.....	3-3
3-3.1 I-F CRYSTAL FILTER SELECTION.....	3-3
3-3.2 CLOCK.....	3-3
3-3.3 10-MINUTE ID TIMER.....	3-3
3-4.1 SIMPLEX OPERATION.....	3-4
3-4.2 "SPLIT" VFO OPERATION.....	3-4
3-4.3 UNDERSTANDING RIT/XIT.....	3-4
3-4.4 RIT/XIT AND MEMORY.....	3-4
3-4.5 RIT OPERATION.....	3-4
3-4.6 XIT OPERATION.....	3-4
3-4.7 SIMULTANEOUS RIT/XIT.....	3-5
3-4.8 VFO A/B.....	3-5
3-4.9 CROSS BAND OPERATION.....	3-5
3-5.0 THE MEMORY SYSTEM.....	3-5
3-5.1 USING THE "SCRATCH PAD".....	3-5
3-5.2 BAND REGISTERS.....	3-5
3-5.3 MEMORY STORE.....	3-5
3-5.4 "MEMORY FULL".....	3-6
3-5.5 MEMORY RECALL BY CHANNEL NUMBER.....	3-6
3-5.6 USING MEMORY SCROLL.....	3-6
3-5.7 MEMORY TUNE.....	3-6
3-5.8 SCANNING SPEED.....	3-6

TABLE OF CONTENTS (continued)

<u>PARAGRAPH</u>	<u>PAGE</u>
3-5.8 SCANNING SPEED	3-6
3-5.9 AUTOMATIC MEMORY TUNE	3-6
3-5.10 PROGRAMMABLE SCAN	3-6
3-5.11 OTHER KEYBOARD FEATURES	3-7
3-6.0 OTHER FRONT PANEL CONTROLS	3-7
3-6.1 RF OUTPUT POWER	3-7
3-6.2 FORWARD AND REFLECTED POWER	3-7
3-6.3 MIC GAIN	3-7
3-6.4 SPEECH PROCESSOR USE	3-7
3-6.5 RECEIVER ATTENUATOR	3-8
3-6.6 NOISE BLANKER	3-8
3-6.7 AGC ON/OFF	3-8
3-6.8 AGC FAST/SLOW	3-8
3-6.9 USING THE S-METER	3-8
3-6.10 AUDIO (AF) AND TONE CONTROLS	3-8
3-6.11 RF GAIN AND SQUELCH	3-8
3-6.12 PTT/VOX SWITCH	3-8
3-6.13 QSK FAST/SLOW	3-8
3-6.14 MIC CONNECTOR	3-8
3-6.15 PHONES JACK	3-9
3-7.0 UNDERSTANDING THE SELECTIVITY SYSTEM	3-9
3-7.1 BP/FADE	3-9
3-7.2 PBT/NOTCH	3-9
3-8.0 REAR PANEL ADJUSTMENTS	3-9
3-8.1 SIDETONE CONTROLS	3-10
3-8.2 MONITOR LEVEL	3-10
3-8.3 BEEP/VOICE	3-10
3-8.4 VOX CONTROLS	3-10
3-8.5 MAIN/AUX ANTENNA SWITCH	3-10
3-9.0 REAR PANEL CONNECTORS	3-10
3-9.1 AUX RX ANTENNA	3-10
3-9.2 50-OHM ANTENNA	3-10
3-9.3 POWER	3-10
3-9.4 FUSE	3-10
3-9.5 GND	3-10
3-9.6 INTERFACE PORT	3-10
3-9.7 SERIAL PORT	3-11
3-9.8 EXT SPEAKER	3-11
3-9.9 AUDIO OUT	3-11
3-9.10 AUDIO IN	3-11
3-9.11 PTT	3-11
3-9.12 KEY	3-11

TABLE OF CONTENTS (continued)

<u>PARAGRAPH</u>	<u>PAGE</u>
3-9.13 RTTY KEY.....	3-11
3-9.14 MARK/SPACE	3-11
3-9.15 AUX.+13.5V.....	3-11
3-9.16 RELAY (N.O.).....	3-11
3-9.17 TX OUT/TN EN	3-11
3-9.18 XVRT EN/XVRT OUT.....	3-11
4. CIRCUIT DESCRIPTIONS AND ILLUSTRATIONS	
4-1 INTRODUCTION.....	4-1
4-2 LOGIC BOARD (81267-1)	4-2
4-3 VF DISPLAY BOARD (81269-1).....	4-7
4-4 UPPER POT BOARD (81326).....	4-10
4-5 SWITCH BOARD (81327)	4-12
4-6 VF DISPLAY CONTROL BOARD (81359).....	4-14
4-7 RAM/ROM/RTC BOARD (81360-1).....	4-17
4-8 CONTROL FILTER BOARD (81377).....	4-21
4-9 RX BANDPASS FILTER (81574).....	4-22
4-10 POWER AMPLIFIER (81611).....	4-25
4-11 TRANSMIT LOW PASS FILTER (81621).....	4-28
4-12 DC POWER INPUT BOARD (81622).....	4-31
4-13 DB-25 BOARD (81628).....	4-34
4-14 SECOND MIXER (81629).....	4-36
4-15 FIRST MIXER (81630).....	4-39
4-16 PASSBAND TUNING BOARD (81631)	4-44
4-17 IF/AF BOARD (81632).....	4-48
4-18 LOW LEVEL AMP./NOISE BLANKER (81633).....	4-52
4-19 TRANSMIT AUDIO/BFO BOARD (81634).....	4-56
4-20 AM/FM BOARD (81635)	4-61
4-21 PHASE LOCKED LOOP BLOCK DIAGRAM.....	4-65
4-22 PLL MAJOR LOOP BOARD (81636).....	4-68
4-23 PLL MINOR LOOP BOARD (81637).....	4-72
4-24 REFERENCE OSCILLATOR (81638).....	4-76
4-25 CONTROL BOARD (81639).....	4-79
4-26 SIDETONE BOARD (81689).....	4-82
4-27 LOWER POT BOARD (81690).....	4-84
4-28 KEYPAD BOARD (81693).....	4-86
4-29 RS-232 INTERFACE CARD (81700).....	4-89
5. PARAGON II SERIAL INTERFACE	
5.1 INTRODUCTION.....	5-1
5.2 COMMAND/CONTROL OPERATIONS OF TEN-TEC TRANSCEIVERS	5-2

TABLE OF CONTENTS (continued)

<u>PARAGRAPH</u>		<u>PAGE</u>
5.3	COMMAND/DATA FORMATS - COMPUTER TO TRANSCEIVER.....	5-2
5.4	RESPONSE STRINGS - RADIO TO COMPUTER.....	5-3
5.5	DATA FORMATS	5-3
5.6	COMMANDS	5-4
5.7	EXPANDED COMMANDS FOR THE OMNI VI AND PARAGON II.....	5-11
	MODELS 563 AND 586 ONLY	

LIST OF ILLUSTRATIONS

<u>FIGURE</u>		<u>PAGE</u>
1-1	DC POWER CABLE CONNECTIONS	1-1
1-2	MICROPHONE CONNECTION	1-2
1-3	6.3 MHZ CRYSTAL FILTER INSTALLATION	1-3
1-4	VOICE BOARD INSTALLATION	1-4
1-5	QSK HOOK-UP WITH HERCULES I AMPLIFIER	1-5
1-6	QSK HOOK-UP WITH CENTURION OR TITAN AMPLIFIER.....	1-5
1-7	QSK HOOK-UP WITH HERCULES II AMPLIFIER AND	1-6
	MODEL 253 AUTOMATIC COUPLER	
1-8	HOOK-UP WITH NON TEN-TEC AMPLIFIERS.....	1-7
3-1	MODEL 586 FRONT VIEW	3-13
3-2	MODEL 586 REAR VIEW	3-13
3-3	MODEL 586 TOP VIEW	3-14
3-4	MODEL 586 BOTTOM VIEW	3-15
4-1	LOGIC BOARD COMPONENT LAYOUT (81267-1).....	4-4
4-2	LOGIC BOARD SCHEMATIC	4-5
4-3	VF DISPLAY BOARD COMPONENT LAYOUT (81269-1)	4-7
4-4	VF DISPLAY BOARD SCHEMATIC	4-8
4-5	UPPER POT BOARD COMPONENT LAYOUT (81326)	4-10
4-6	UPPER POT BOARD SCHEMATIC	4-11
4-7	SWITCH BOARD COMPONENT LAYOUT (81327).....	4-12
4-8	SWITCH BOARD SCHEMATIC	4-13
4-9	VF DISPLAY CONTROL BOARD COMPONENT LAYOUT (81359)	4-14
4-10	VF DISPLAY CONTROL BOARD SCHEMATIC	4-15
4-11	RAM/ROM/RTC BOARD COMPONENT LAYOUT (81360-1)	4-18
4-12	RAM/ROM/RTC BOARD SCHEMATIC	4-19
4-13	CONTROL FILTER BOARD COMPONENT LAYOUT	4-21
4-14	CONTROL FILTER BOARD SCHEMATIC	4-21
4-15	RX BANDPASS COMPONENT LAYOUT	4-22
4-16	RX BANDPASS SCHEMATIC	4-23
4-17	POWER AMPLIFIER COMPONENT LAYOUT	4-26
4-18	POWER AMPLIFIER SCHEMATIC	4-27
4-19	TX LOW PASS FILTER COMPONENT LAYOUT	4-29
4-20	TX LOW PASS FILTER SCHEMATIC.....	4-30
4-21	DC POWER INPUT BOARD COMPONENT LAYOUT.....	4-32
4-22	DC POWER INPUT BOARD SCHEMATIC	4-33
4-23	DB-25 BOARD COMPONENT LAYOUT	4-34
4-24	DB-25 BOARD SCHEMATIC.....	4-35
4-25	SECOND MIXER COMPONENT LAYOUT	4-37
4-26	SECOND MIXER SCHEMATIC.....	4-38

LIST OF ILLUSTRATIONS (continued)

<u>FIGURE</u>		<u>PAGE</u>
4-27	FIRST MIXER COMPONENT LAYOUT	4-41
4-28	FIRST MIXER SCHEMATIC	4-42
4-29	PASSBAND TUNING BOARD COMPONENT LAYOUT	4-45
4-30	PASSBAND TUNING BOARD SCHEMATIC	4-46
4-31	IF/AF BOARD COMPONENT LAYOUT	4-49
4-32	IF/AF BOARD SCHEMATIC	4-50
4-33	LOW LEVEL AMP./NOISE BLANKER COMPONENT LAYOUT	4-53
4-34	LOW LEVEL AMP./NOISE BLANKER SCHEMATIC	4-54
4-35	TRANSMIT AUDIO/BFO BOARD COMPONENT LAYOUT	4-58
4-36	TRANSMIT AUDIO/BFO BOARD SCHEMATIC	4-59
4-37	AM/FM BOARD COMPONENT LAYOUT	4-62
4-38	AM/FM BOARD SCHEMATIC	4-63
4-39	PLL BLOCK DIAGRAM SCHEMATIC	4-66
4-40	PLL MAJOR LOOP BOARD COMPONENT LAYOUT	4-69
4-41	PLL MAJOR LOOP BOARD SCHEMATIC	4-70
4-42	PLL MINOR LOOP BOARD COMPONENT LAYOUT	4-73
4-43	PLL MINOR LOOP BOARD SCHEMATIC	4-74
4-44	REFERENCE OSCILLATOR COMPONENT LAYOUT	4-76
4-45	REFERENCE OSCILLATOR SCHEMATIC	4-77
4-46	CONTROL BOARD COMPONENT LAYOUT	4-80
4-47	CONTROL BOARD SCHEMATIC	4-81
4-48	SIDETONE BOARD COMPONENT LAYOUT	4-82
4-49	SIDETONE BOARD SCHEMATIC	4-83
4-50	LOWER POT BOARD COMPONENT LAYOUT	4-84
4-51	LOWER POT BOARD SCHEMATIC	4-85
4-52	KEYPAD BOARD COMPONENT LAYOUT	4-86
4-53	KEYPAD BOARD SCHEMATIC	4-87
4-54	RS232 INTERFACE CARD COMPONENT LAYOUT	4-90
4-55	RS232 INTERFACE CARD SCHEMATIC	4-91
5-1	CONNECTION OF PARAGON II TO COMPUTER	5-1
5-2	RS232 CABLE WIRING CONNECTIONS	5-1

MODEL 586 SPECIFICATIONS

GENERAL

MODES	USB, LSB, CW, FSK OR AFSK, FM, AM
FREQUENCY RANGE	Receive: 100 KHz to 29.9999 MHz Transmit: Standard Ham Bands 160M-10M
FREQUENCY CONTROL	Microprocessor controlled digital PLL synthesizer. 10 Hz resolution.
FREQUENCY READOUT	7 digit 10 Hz fluorescent readout.
FREQUENCY STABILITY	Worst case, 1 PPM per degree C. at 29.999 MHz.
OFFSET TUNING	\pm 99.99 receive and transmit
DUAL VFOs	with SPLIT mode
MEMORIES	60 duplex memories, one scratch pad memory (battery backup, 8-10 yrs. life)
PC INTERFACE	Serial port operation of receive and transmit. Includes two line and RS-232 interface. Runs at 1200 baud.
FREQUENCY ACCURACY	\pm 50 Hz @ 25 degrees C.
ANTENNA	50 ohm unbalanced
REMOTE BAND SWITCHING	Provides bandswitching data for Hercules II, Model 420 and Model 253 auto antenna tuner.
POWER REQUIRED	2 A receive, 20 A transmit @ 12 - 14 VDC
CONSTRUCTION	G10 epoxy glass PC boards, most field replaceable. Extruded aluminum front panel, aluminum chassis, texture painted top & bottom, snap up stainless steel bail.
DIMENSIONS	HWD 5.75" x 14.75" x 17" - (14.6 x 37.5 x 43.2 cm)
WEIGHT	16 lbs - 7.25 kg.

TRANSMITTER

RF OUTPUT	0 - 100 watts, ALC stabilized
DC INPUT	Maximum 250 watts @ 14VDC. 100% duty cycle for up to 20 minutes. Continuous duty with customer supplied air cooling of rear panel heat sink.
MICROPHONE INPUT	200 - 50K Ohms, accepts microphones with 5mV (-62dB) output. Polarizing voltage for electrets provided.
SPEECH PROCESSOR	Adjustable compression level
T/R SWITCHING	PTT or VOX on SSB, switchable FAST or SLOW QSK on CW.
CW OFFSET	700 Hz

SIDETONE	Generated internally with rear panel tone and level controls.
FSK SHIFT	170 Hz.
FM DEVIATION	+/- 5 KHz
METERING	Switchable to forward power, SWR, collector current or audio processing level on SSB.
SSB GENERATION	Balanced modulator followed by 9 MHz, 8 pole crystal ladder filter.
CARRIER SUPPRESSION	60 dB typical
UNWANTED SIDEBAND SUPPRESSION	60 dB typical at 1.5 KHz tone.
THIRD ORDER INTERMOD	30 dB below two tone at 100 watts PEP.
SPURIOUS OUTPUT	Better than 45 dB below peak power output.

RECEIVER

SENSITIVITY

FREQUENCY MHz		
MODE		
	.1 - 1.6	
SSB, CW, FSK	.5 μ V	10dB S/N
FM	1.0 μ V	12dB SINAD
AM	3.5 μ V	10 dB SINAD

SELECTIVITY

SELECTED FILTER	SELECTIVITY		Shape factor
	-6 dB	-60 dB	
STANDARD 2.4 KHz	2.4 KHz	4.50 KHz	1.87 : 1
OPTIONAL 1.8 KHz	1.8 KHz	3.40 KHz	1.89 : 1
OPTIONAL 500 Hz	500 Hz	1.40 KHz	2.80 : 1
OPTIONAL 250 Hz	250 Hz	850 Hz	3.40 : 1
STANDARD FM	15.0 KHz	30.0 KHz	2.00 : 1
STANDARD AM	6.0 KHz	11.25 KHz	1.87 : 1

DYNAMIC RANGE	97 dB @ 2.4 KHz bandwidth at 20 KHz spacing, 100 dB + with CW filters.
THIRD ORDER	+15 dBm
NOISE FLOOR	-133 dBm
S-METER	Calibrated to 50 μ V at S9.
ATTENUATOR	-20 dB

PASSBAND TUNING	+/- 1.2 KHz
I-F FREQUENCIES	1st I-F 70 MHz, 2nd I-F 9.0 MHz, 3rd I-F 6.3 MHz (3rd I-F for FM 455 KHz.)
NOISE BLANKER	Adjustable width.
MANUAL NOTCH FILTER	250 Hz to 2.2 KHz, greater than 50 dB
RECEIVE RECOVERY TIME	Less than 35 ms
SQUELCH SENSITIVITY	Less than 1.0 μ V
IMAGE REJECTION	> 80 dB
I-F REJECTION	> 70dB
AUDIO	1.5 watts @ 4 ohms with less than 2% distortion, built-in speaker, separate fixed output 1 mw @ 600 ohms.
SEPARATE RX ANTENNA INPUT	50 ohm phono jack, rear panel selectable.
AUDIO BANDPASS FILTER	4 pole, variable center frequency 220 to 1.7 KHz, 35% bandwidth @ -6 dB. Variable fader control selects filtered or flat audio response.
TONE CONTROL	Variable 15 dB rolloff @ 5 KHz

BEFORE YOU DO OR READ ANYTHING ELSE . . .

1. Check your transceiver for any sign of shipping damage.
2. Check the "UNPACKING" section of this manual to make sure you received all standard accessories.
3. Study Section 1-1 regarding DC voltage requirements.
4. ALWAYS turn the Paragon II on and off by its own front panel switch, not by its power source.
5. If DC voltage is being supplied by an alternator or generator system, ALWAYS turn the radio on AFTER the system is running properly. Likewise, turn the radio off BEFORE shutting down the vehicle or generator system.
6. Be aware that the keypad button marked TUNE turns on or "keys" the transmitter (in CW mode) for as long as its red LED is on.
7. The keypad indicates several functions which are operational only if the appropriate optional board is installed, such as extra CW filters and voice announcement of frequency.

UNPACKING

Examine your transceiver immediately for any sign of shipping damage. Should any such damage be apparent, notify the shipping carrier immediately, stating the full extent of the damage. Liability for shipping damage rests fully with the carrier. Be sure to retain all damaged cartons for their inspection.

We recommend that you save shipping cartons and fillers for convenience and safety in any possible storage, moving or reshipment.

The following hardware and accessories are packed with your Model 586 PARAGON II. Make sure you have not overlooked anything.

- 3 ___ #35003 Phono Plug
- 1 ___ #35057 4-pin Mic. connector
- 1 ___ #38040 .050" Allen Wrench
- 1 ___ #38088 .062" Allen Wrench
- 1 ___ #38057 4-pin Power Cable connector
- 4 ___ #41020 female pins for connector
- 1 ___ #74020 Ten-Tec Warranty Card
- 1 ___ #74242 Operator's Manual
- 1 ___ #86055 DC Power Cord
- 1 ___ #27045 Spare AGC 25 Fuse

If any of the previous items are missing, contact the repair department at TEN-TEC for replacements.

Repair Department.....615-428-0364
Switchboard615-453-7172
FAX615-428-4483

...the ... of ...

...the ... of ...

...the ... of ...

...

...the ... of ...

...the ... of ...

...the ... of ...

...the ... of ...

...

INTRODUCTION

We at TEN-TEC thank you and congratulate you for choosing this high-performance transceiver engineered and manufactured in the USA.

The dictionary states clearly what we intend in the design of the PARAGON series of general coverage transceivers:

par. a gon: a model or pattern of excellence.

At first glance, the PARAGON II will look like a comfortable old friend to radio operators familiar with the classic PARAGON, or the OMNI V and OMNI VI transceivers. The most striking difference from the previous PARAGON model is that the PARAGON II provides instant access to the nine HF Amateur Bands from the number keypad. Another difference is the utter simplicity of the new PARAGON II keypad layout. FM mode is now a standard feature, and AM transmit capability is included. And there's much more!

The many other differences and improvements are more subtle and internal, which means that a thorough study of this instruction manual will help you gain maximum enjoyment of the PARAGON II's numerous features. In other words, your PARAGON II can do much more in hands-on operating than its much-simplified control panel may suggest.

Using new equipment is usually a lot more fun than reading about it, and we know that we cannot force you to study this book. We can only encourage you to do so, and we have tried to do our part by making this manual as informative and interesting as possible.

Introduced in 1987, the PARAGON set new standards of excellence and reliability in amateur, commercial and government service. New for 1994, the PARAGON II incorporates enhancements recommended by experienced users of the PARAGON and has benefitted directly from the engineering that produced the highly-acclaimed OMNI VI amateur band transceiver. In a word, we have tried to make PARAGON II a true "model of Excellence" for HF radio operators interested in the whole range of global HF communications plus high-performance amateur band work.

You now own an excellent transceiver. We urge you to learn all about it!

NOTE TO EXPERIENCED PARAGON 585 USERS: PARAGON II (Model 586) was designed in response to your suggestions, providing a blend of the best features of Model 585 with the most practical and popular features of OMNI VI. The differences from your previous PARAGON'S keyboard may take some getting used to, but we're sure you will welcome the improvements.

The OMNI VI is engineered to meet the exacting demands of the most intense competition in DX and contest operations. Your PARAGON II, plus your own grasp of all its capabilities, poises you toward that same level of exacting performance while also offering you world-class receiving capability for AM, FM, SSB, FSK, AFSK, packet, ASCII, WeFAX, CW and other modes from 100 KHz to 30 MHz.

CHAPTER 1 SETTING UP

URGENT: Your PARAGON II requires 12-15 volts DC (direct current). Any attempt to apply 120-240 VAC (AC voltage from wall sockets, etc.) to pins 1 and 4 will cause instant damage which cannot be covered by the otherwise-generous TEN-TEC warranty.

1-1. POWER SUPPLY. Your PARAGON II needs a DC voltage source capable of 12 to 15 volts DC at 22 amps. The ideal power supply provides 13.8 VDC at 22 amperes. A lighter current rating (amps) is OK if you operate the PARAGON II at reduced RF output per the instructions in this manual, or to use only its receiver capability. However, the actual VOLTAGE must be as close to 13.8 volts as possible. Voltage below 10.5 volts can cause microprocessor malfunction and other inferior performance.

While numerous DC power sources are possible, we recommend the matching TEN-TEC Model 961 Power Supply for all fixed-station applications. This attractive "work-horse" has provided no-nonsense reliability throughout the history of TEN-TEC's high-performance transceivers.

Plug it in, connect it to your PARAGON II and get on the air! The Model 961 Power Supply, designed carefully for all PARAGON and OMNI models, provides required DC power, over-voltage and over-current protection, plus RFI bypassing. And, of course, it LOOKS good, includes a front-facing speaker, auxiliary power connections for station accessories, plus instant hookup.

WARNING! If operating from a RV, boat, Field Day installation, or any setup where storage batteries are supported by a generator or alternator, ALWAYS start the generator or alternator before turning on the transceiver. This allows the voltage to stabilize. When shutting down, always turn the transceiver off first. **SERIOUS DAMAGE TO THE TRANS-**

CEIVER CAN OCCUR IF THIS SEQUENCE IS NOT FOLLOWED.

If a storage battery is used to power the transceiver, we recommend the use of a separate 25 AMP fuse in line with the power cables.

When using any DC power source other than the TEN-TEC power supply, we encourage you to use the #86055 DC Power Cable supplied with the transceiver. If you must use some other cord, it must be terminated with the extra 4-pin connector provided, in accord with the following diagram. Be sure the power supply is well-filtered and well-regulated.

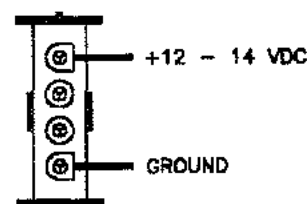

REAR VIEW OF TRANSCEIVER

FIGURE 1-1
DC POWER
CABLE CONNECTIONS

1-2. ANTENNA The PARAGON II is designed so that bad antennas cannot damage it and that good antennas will optimize it. Discussions of suitable antennas are found in ham radio books and magazines. The RF power transistors are protected from all abnormal conditions ranging from a direct short to no antenna connected at all.

While a 50-ohm load impedance is the norm, operation at nearly full power is possible throughout a range of 25 to 100 ohms, as long as the SWR is 2:1 or better.

If the indicated SWR exceeds 2:1, the collector current (I_c) should be limited to 20 amps or less. This is done by setting Meter switch to I_c and adjusting RF PWR control.

Transmitter output is always through the SO-239 coax connector on the rear panel. If an alternate receiving antenna is used, it is connected to the phono jack marked AUX RX ANTENNA and selected with the slide switch immediately below it. Both antennas may be connected at all times.

1-3. MICROPHONE Any TEN-TEC or T-KIT microphone, using our 4-pin connector, may be used without modification. In addition, any other microphone (dynamic, ceramic, crystal or electret), with an impedance of 200 to 50,000 Ohms, may be used. Microphones requiring an external DC voltage source can be powered from pin 4 of the jack, as shown in Figure 1-2. The mike cable must be shielded to prevent RF feedback.

A connector (Part No. 35057) is supplied in the packing kit.



FRONT VIEW OF 586

**FIGURE 1-2
MICROPHONE CONNECTION**

1-4. CW Any manual key, electronic keyer, or computer-operated keying line may be connected to the KEY phono jack on the rear panel. The keyer need only close the keying line to ground. Do not use the "grid block" option provided on some keyers. TEN-TEC currently does not manufacture electronic keyers, but we invite you to explore the T-KIT catalog for easy, economical keyer projects.

1-5. STATION GROUND A good ground system is essential for optimum operation of any transmitter. The best method, especially if you are using a linear amplifier, is to bond all station equipment together with a common grounding wire connected to an eight-foot ground rod. Use a heavy flat-braid conductor, as short as possible.

If you are not using a linear amplifier, a less ideal ground may suffice. Grounding to a true copper or iron pipe cold water supply is usually effective. (Remember that much of today's plumbing consists of plastic PVC which cannot provide useful or safe station grounding.)

If your station location is correctly wired to modern codes, using a separate ground wire to wall receptacles, the electrical supply ground available through a 3-wire power supply AC cable MAY be adequate as a station ground.

The PARAGON II and all TEN-TEC transceivers are engineered to the strictest FCC specifications. If you have RFI or TVI problems, be suspicious of station grounding as well as of the devices exhibiting interference. If you have no practical way of physically improving your ground system, consider the T-KIT Model 1251 RF Counterpoise or other "artificial ground" devices. These will not improve transceiver performance but MIGHT solve TVI/RFI problems and the phenomenon of a "hot" chassis, key, or microphone.

1-6 OTHER ACCESSORY EQUIPMENT Connections and circuitry are provided for all contemporary HF communications modes including true FSK.

Basic hookup and operating details are provided in this manual as regards the transceiver's role in such systems, but it is important that you understand the hardware and software requirements of any peripheral equipment connected to the PARAGON II.

The rear panel connections permit the use of a wide variety of accessory equipment, ranging from a simple external speaker to VHF transverters to linear amplifiers. See the Table of Contents to locate detailed information. If you plan to use a non-TEN-TEC RF amplifier, be especially alert to making connections correctly.

1-7 TEN-TEC ACCESSORIES FOR PARAGON II

- 236..... Remote Control Cable for connecting to either a Model 253 or Model 420
- 238..... 2 Kw Manual Antenna Tuner
- 239..... Dummy Load
- 257..... Voice Synthesizer
- 259..... Universal ALC Annunciator
- 264..... 236 Expansion Cable for connecting Model 253/420 combination to PARAGON II
- 282..... 250 Hz 6 Pole Ladder Filter, 6.3 MHz
- 285..... 500 Hz 6 Pole Ladder Filter, 6.3 MHz
- 288..... 1.8 KHz 8 Pole Ladder Filter, 6.3 MHz
- 305..... Serial Level Converter
- 700C... Handheld Mike, Electret with Coiled Cord and 4 Pin Connector
- 705..... Desk Mike, Electret, with Coiled Cord and 4 pin Connector
- 961..... Power Supply, 115/230 VAC, 13.8 VDC, 22 A, built-in Speaker
- 5061... Lowpass Line Filter
- 35057. 4 Pin Microphone Connector
- RM-500.... Rack mount kit
- 80-572..... Spare, 4 Pin DC Connector

1-8 INSTALLING INTERNAL OPTIONS

All accessory crystal filters, Model 257 Voice Synthesizer and Model 259 ALC Annunciator mount inside the PARAGON II. Refer to the following paragraphs to remove top and bottom covers and install the desired option(s).

1-8.1 REMOVAL OF TOP & BOTTOM COVERS To remove the top cover, remove the upper two of the four (4) large Phillips screws located on each side. Slide the top back and out from under the rear lip of the extruded front panel. Be certain to unplug the speaker cable when removing the top.

To remove the bottom cover, remove the lower two (2) large Phillips screws on each side. With the transceiver upside down and the front panel facing forward, slide the bottom

cover back and out from underneath the rear lip of the extruded front panel.

1-8.2 OPTIONAL CRYSTAL FILTERS

Up to three (3) optional crystal filters may be installed in the PARAGON II. The Model 288 (1.8 KHz), Model 285 (500 Hz), and Model 282 (250 Hz) filters may be installed in the 6.3 MHz I-F as shown in FIGURE 1-3. These optional filters install on the Pass Band Tuning Board (81631) located on the bottom side of the transceiver. The filters may be installed in either direction.

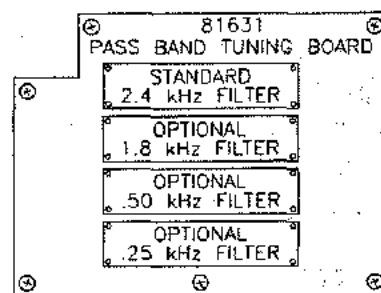

**FIGURE 1-3
6.3 MHz CRYSTAL FILTER
INSTALLATION**

1-8.3 OPTIONAL VOICE SYNTHESIZER, MODEL 257

The Voice synthesizer announces the display frequency when the VCE button is pressed. The Voice board plugs into an edge card connector on the Logic Board. Refer to FIGURE 1-4 for the location of the edge card connector.

After installing it, press the VCE button and adjust the speech level control, located on the Voice synthesizer board, to a suitable level. For more detailed information, refer to the Model 257 instruction manual.

NOTE: If voice does not function, check voice board for diode, D1 (1N4148) near edge connector on front left side. If diode is jumpered, cut wire jumper. If not, contact factory for assistance.

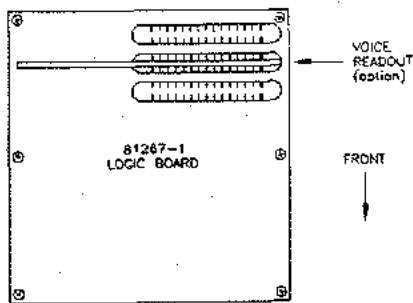

**FIGURE 1-4
VOICE BOARD INSTALLATION**

1-8.4 OPTIONAL ALC ANNUNCIATOR, MODEL 259 This accessory allows the vision impaired operator to adjust the MIC GAIN control properly. For installation instructions refer to the Model 259 manual.

1-8.5 INTERFACING WITH OTHER TEN-TEC EQUIPMENT When connecting other TEN-TEC equipment such as an amplifier or automatic tuner, refer to Figures 1-5, 1-6, 1-7, or 1-8 on the following pages for connecting diagrams.

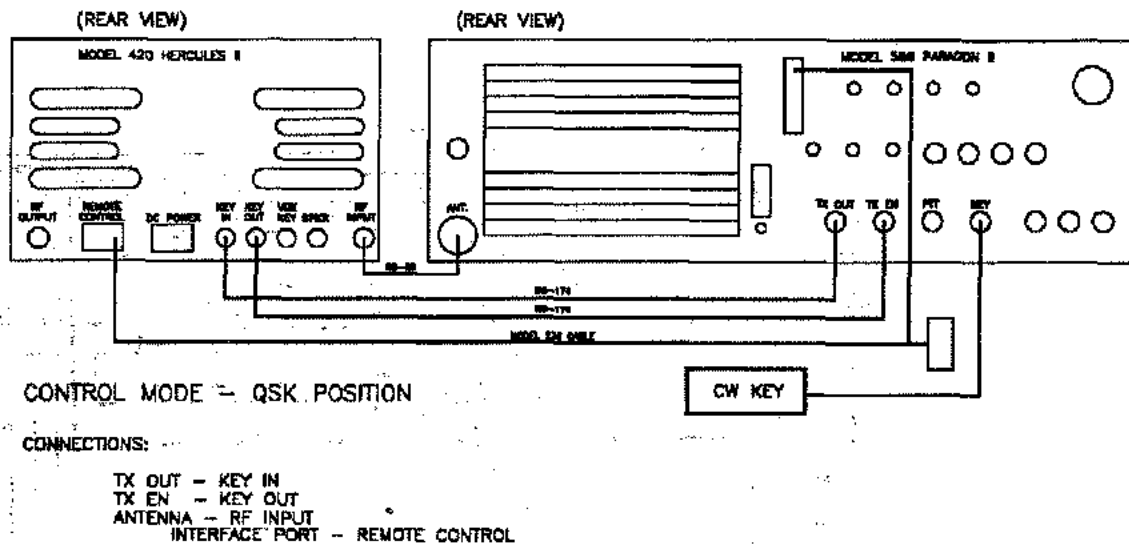

FIGURE 1-5. QSK HOOK-UP WITH HERCULES II AMPLIFIER

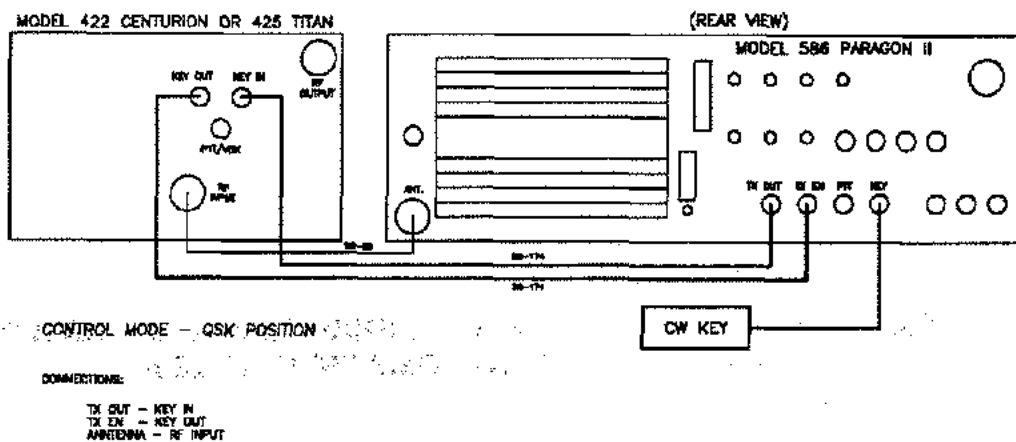
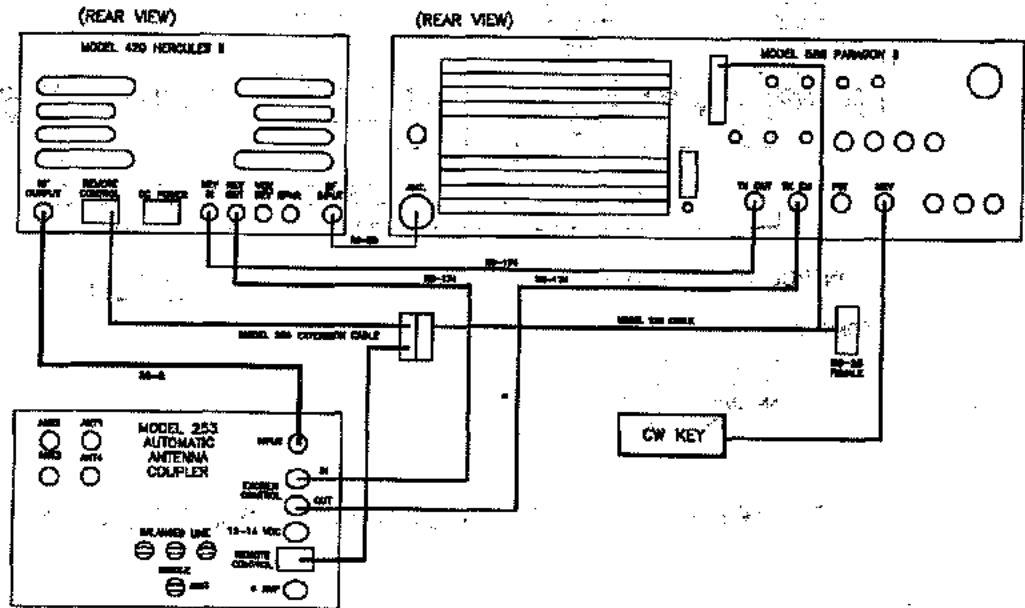

FIGURE 1-6. QSK HOOK-UP WITH CENTURION OR TITAN AMPLIFIER



CONTROL MODE -- QSK POSITION

CONNECTIONS:

- TX OUT - KEY IN
- TX EN - KEY OUT
- ANTENNA - RF INPUT
- INTERFACE PORT - REMOTE CONTROL

FIGURE 1-7. QSK HOOK-UP WITH HERCULES II AMPLIFIER AND MODEL 253 AUTOMATIC COUPLER

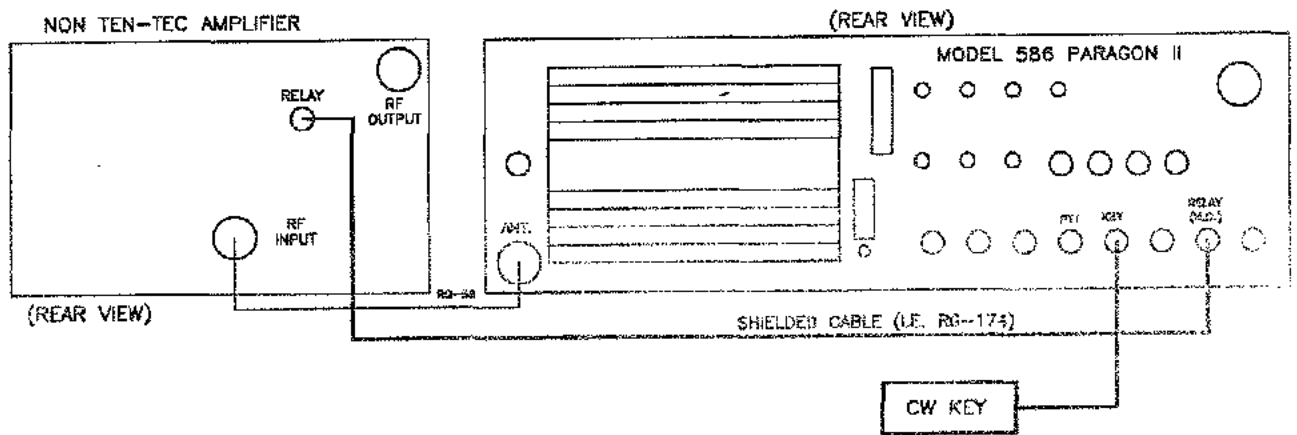

FIGURE 1-8. HOOK-UP WITH NON TEN-TEC AMPLIFIERS

CHAPTER 2

GETTING STARTED

The purpose of this chapter is simply to help you GET STARTED in using your new PARAGON II through brief explanations of the Keyboard functions and initial settings of the other controls. Chapter 3 provides a more detailed look at ALL the functions and capabilities of the transceiver. Chapter 2 is organized this way:

- 2-1. About this Manual
- 2-2. Quick-Reference to Keyboard Functions
- 2-3. Extended Keyboard Functions
- 2-4. Powering Up
- 2-5. Front Panel Orientation
- 2-6. Initial Transmit Test
- 2-7.1. Operating SSB
- 2-7.2. Operating CW
- 2-7.3. Operating AM
- 2-7.4. Operating FM
- 2-7.5. Note on Digital Modes
- 2-8. Understanding the Microprocessor
- 2-9. Memory: A Brief Tutorial (optional)
- 2-10. Summary

2-1. ABOUT THE STYLE AND CONVENTIONS OF THIS INSTRUCTION MANUAL

Your transceiver is a sophisticated integration of analog and digital circuitry. The ANALOG functions are controlled by potentiometers and switches organized on the left half of the front panel. These controls and switches will be referred to as needed by their names or abbreviations just as you see them on the front panel. We will explain their use in plain language and normal text typefaces. We will do the same when explaining the rear panel adjustments and connectors.

The DIGITAL functions of the microprocessor are managed at the KEYBOARD and

the cluster of push keys surrounding the Main Tuning knob. Integral to the Keyboard is the NUMBER PAD, the 12 multi-function keys marked primarily by the 9 HF amateur bands, plus 0-9 and the up/down arrow keys.

In explaining the many possible functions of the keyboard switches in this book, we will ask you to press a key such as [VFO>M] or [XIT], or a sequence of keys, always identifying the key by the square brackets [] and the simpler, bold typeface. Some commands to the microprocessor will require a SEQUENCE of pressing keys, which we will print like this:

Press [ENTER] [7] [0] [1] [ENTER].

(The above command sequence would set the VFO frequency to 7010.00 kHz.)

IMPORTANT: Unless specifically stated otherwise for rarely-used functions, ALL keyboard entries are in sequence or "serial." You do NOT have to hold down the first key while pressing the next one.

TIP: If you find it difficult to press the keys directly with your fingertips, simply use the clean eraser end of an ordinary pencil! Remember: simply press the keys in the order needed.

2-2. QUICK-REFERENCE INTRODUCTION TO PARAGON II KEYBOARD FUNCTIONS

Most of us can scan the knobs and buttons of today's transceivers and "get it going — kinda"! The purpose of this section is to acquaint you with the keyboard functions that might not be completely "obvious" in your experience of comparing various transceivers. This information will be repeated and expanded in our complete explanation of ALL controls, switches and connectors.

[TUNE] keys or "turns on" the transmit section in CW mode. It is used only when checking SWR, collector current ("Ic" on the meter) or adjusting power output, an antenna tuner or linear amplifier. See also 3-1.4.

[CW] [USB] [LSB] [AM] [FM] Press to select Mode. See 3-1.4 and 3-1.5 regarding AM transmitting and FSK.

[6.0] [2.4] [1.8] [.50] [.25] Press to select desired receive bandwidth from among filters actually installed. 6.0 KHz and 2.4 KHz filters are standard equipment. 1.8 KHz, 500 Hz and 250 Hz filters are optional.

[RIT] turns "Receive Incremental Tuning" on and off. Allows you to tune the receive frequency slightly above or below the transmit frequency without changing the transmit frequency.

[XIT] turns "Transmit Incremental Tuning" on and off. Allows you to tune the transmit frequency slightly above or below the receive frequency without changing the receive frequency.

[A=B] Pressing this key makes the VFO not in use identical to the active VFO. Actual use of this feature is determined by personal operating habits.

[A/B] instantly toggles (switches) between VFO A and VFO B.

[SPLIT] receiving on one VFO and transmitting with the other. See the detailed operating instructions for further information.

[REV] Pressing (and HOLDING) this key lets you listen temporarily on the offset frequency selected by [RIT] or [XIT], or the opposite VFO if [SPLIT] is on. This is the only key that needs to be pressed in for the duration of its function.

[VFO>M] Stores currently displayed frequency, mode, and filter to memory channel of your choice.

[M>VFO] = Recalls contents from desired memory channel to VFO.

[MS] Memory Scroll lets you examine all memory contents, using Main Tuning, without disturbing reception of the current VFO frequency. Do not try to transmit while scrolling Memory.

[MT] Memory Tune lets you tune through and receive on each memory channel with Main Tuning Knob.

[PS] and [SPD] Programmable Scan and scanning/tuning Speed rate. See 3-5.9. for explanation.

[ML] Memory Lock. Its purpose is to block selected memory frequencies during Memory Tune or Automatic Memory Tune functions. The same key is also used to unlock those channels.

[DIS] Display provides a choice of: clock with seconds, clock with minutes, clock turned off. Also used to set 10 minute ID Timer. See section 3-3.3.

[SET] Used to set the clock and computer interface address.

[LCK] Lock (and unlock) Main Tuning.

[FAST] Increases tuning rate of Main Tuning and [UP] [DOWN] keys when changing frequency. See Chapter 3 for details.

[VCE] Press to activate voice announcement of frequency (if optional Model 257 is installed.)

[ENTER] [CLEAR] [SHIFT] A clear understanding of these three keys is important to smooth and enjoyable use of the transceiver.

[ENTER] is used to BEGIN (and often to end) direct entry of a frequency into the VFO currently in use. Because the amateur bands are accessed so easily from the number pad, most operators will use this procedure primarily to tune in other HF radio services.

[CLEAR] instantly lets you abort a key sequence that is not going well, returning you to the frequency in use before [ENTER] was pressed.

[SHIFT] is similar to the [CTRL] or [ALT] key on computer keyboards in that it permits some other key to perform an additional function. For example, pressing [SHIFT] [MT] will initiate "Automatic Memory Tune" or scanning of all memory frequencies.

2-3. GLOSSARY OF EXTENDED KEYBOARD FEATURES AND FUNCTIONS

The PARAGON II microprocessor is programmed to provide various features not obvious on the keyboard itself. These capabilities are "invisible" unless you know how to access them. Here is a brief listing of those features and how to use them:

2-3.1. AUTOMATIC MEMORY TUNE If you press [SHIFT] [MT], all memory channels are scanned automatically at a speed determined by the 00-09 range of the [SPD] function. See 3-5.8.

2-3.2. BAND REGISTERS This is our term for the fact that you can store any TWO frequencies for each amateur band without using Memories. See 3-5.2. regarding use.

2-3.3. FSK MODE True FSK (RTTY Frequency Shift Keying) is enabled by pressing [SHIFT] [CW]. The indication that you are in FSK mode is that NONE of the mode LEDs are lit!

2-3.4. MATRIX MODE "Matrix Mode" is used ONLY by those operators who interface the transceiver to a computer. This mode is turned on (and off) by pressing [SHIFT] [A/B]. The letter "M" will appear to the far right of the clock display while this mode is in use. See Chapter 5.

2-3.5. SCRATCH PAD MEMORY This feature lets you store one frequency of special interest until you have time to check it again or decide if you wish to place it in permanent

memory. To store a frequency, press [VFO>M] TWICE. Scratch pad storage is confirmed if you see "SP" briefly in the center of the display section. See 3-5.1.

2-3.6. CLEAR ALL MEMORIES Use this option very deliberately, because there is no "undo" command after you press the third key. Pressing [SHIFT][PS][ENTER] will erase all memories, clear band registers and return other programmed values to factory defaults.

2-4. FIRST POWER-UP (RECEIVE ONLY)

Power supply per 1-1.
Antenna per 1-2.
Ground per 1-3.

SET CONTROLS: (CCW = counter-clockwise)

N.B. Width: full CCW
Processor: full CCW
Meter: FWD
AF: 9:00
Tone: 12:00
Fade: full CCW
BP: 12:00
PBT: 12:00
Notch: full CCW
MIC: full CCW
PWR: full CCW
RF: full clockwise
SQL: full CCW

SET PUSH SWITCHES:

NB: OFF
PTT/VOX: PTT
QSK: FAST
AGC: ON
AGC: FAST
ATTN: Out
PROC: OFF (no LED)

TURN POWER ON AND CHECK KEYBOARD:

ALL keyboard LED's should be OFF except as required by the following:

- Use [A/B] to choose VFO A
- Press Band of interest
- Press Mode of interest
- Press Filter [2.4]
- Press [DIS] until clock display is off

2-5. FRONT PANEL ORIENTATION Take a little time to become familiar with the effects of the various controls that are not part of the keyboard. Be aware that S-meter operation requires that AGC be ON and that accurate readings require RF Gain to be fully clockwise. Then, experiment at your leisure with any keyboard buttons of immediate interest, remembering that [TUNE] is a Transmit function only (see below).

This could be a good time to try the procedures suggested in the optional Memory Tutorial (Section 2-9).

2-6. INITIAL TRANSMIT TEST This test assumes that you have a reasonable transmitting antenna (or 50-ohm dummy load such as TEN-TEC Model 239). If testing with antenna, preview Section 2-7 below and prepare to transmit appropriate station ID by CW or voice as part of test procedure.

- Select Band and Frequency on which you are licensed to transmit.
- Press [TUNE] (red LED on).
 - Advance RF PWR control clockwise until meter needle no longer advances.
- Observe approximate power output in watts on FWD meter scale.
- Turn meter switch to REF and observe SWR.
- If SWR is greater than 2:1, turn meter switch to Ic. Then, use RF PWR control as needed to ensure that Ic on the meter scale does not exceed 20 (amps).
- Press [TUNE] to turn off transmitted carrier.

2-7.1. SSB OPERATION. Depending on the band you choose, select either USB or LSB on the keyboard. Remember that, for now, the transceiver is set for PTT operation. Choose a clear frequency, press the mike button and, while speaking into the mike, advance MIC control so that the green ALC LED blinks on voice peaks. You are now ready for basic simplex SSB operation. If you get on the air before further study of this book, remember that you can press [RIT] to fine-tune the received signal (with the Main Tuning knob) without altering your transmit frequency. Press [RIT] again to return receiver to transmit frequency. If there is bothersome interference on the received signal, adjust the PBT control. See Chapter 3 regarding VOX operation and full use of the selectivity controls.

2-7.2. CW OPERATION. Plug a keyer or straight key into the rear KEY phono jack and press [CW] on the keyboard. If you do not want fast break-in CW, switch QSK to SLOW. If the optional filters are installed, select the one of your choice and then adjust PBT for best results.

2-7.3. AM OPERATION Pressing [AM] places the receiver (only) in AM mode. For AM transmit operation, press either [LSB] or [USB] while holding [AM], which will light both LED's (AM and LSB or AM and USB.) The resulting mode will be either USB or LSB with carrier. Most operators will set RF PWR control full clockwise. Press the mike button and, while speaking into the mike, adjust MIC control so ALC LED just blinks on voice peaks.

2-7.4. FM OPERATION Press [FM] to place transceiver in FM mode for both receive and transmit. If necessary, tune VFO to the nearest 0 or 5 kHz, such as 29.000 or 29.005. Note that the [UP]/[DOWN] buttons on the number pad move the frequency in 5 kHz steps (if FAST

off). Using any unoccupied frequency, adjust SQL for receiver quieting just as you would adjust any FM handheld or scanner.

In FM operation, the MIC gain control works as a FM deviation control and should be set to about 9:00 when using TEN-TEC or T-KIT microphones.

Remember that FM operation is authorized for 29.0 to 29.7 MHz only, plus VHF bands if using a transverter. For repeater offsets, set VFO A for receiving (repeater output) and VFO B for transmitting (repeater input) and press [SPLIT]. The transceiver will operate in Split mode until you press [SPLIT] again. Splits may be saved in Memory: see 3-4.2.

2-7.5. DIGITAL, ATV AND OTHER MODES. Please consult Chapters 3 and 5 and all documentation supplied with the accessory equipment you wish to use.

2-8. UNDERSTANDING THE MICROPROCESSOR. Remember that your transceiver is as much computer as it is receiver and transmitter.

The Logic section uses a microprocessor, memory and programming. Microprocessor technology has improved dramatically, to the extent that the PARAGON II's processor executes its own check sum analysis and performs certain reset functions automatically. However, the system is still vulnerable to power spikes or surges, power interruptions or an unforeseen set of circumstances, causing a lockup.

If the keyboard becomes non-responsive, or the display does not make sense, the first step is simply to turn the transceiver OFF and wait a few seconds. If normal operation is not restored when you turn it back on, you need to perform a RESET from the keyboard.

2-8.1 RESET PROCEDURE This will NOT erase the Memories or band registers but will clear the clock. Turn OFF the transceiver by its front panel POWER switch. Wait 5-10 seconds. HOLD DOWN the [ENTER] key while turning POWER back on. Hold [ENTER] for several seconds and then release it. The display should show 15.000.00 MHz on VFO A, and the clock

memory looks OK, the simple RESET was successful. If the memory information appears invalid, double-check it against any logs or notes you have kept. If necessary, ALL memories are cleared instantly by pressing [SHIFT][PS]ENTER].

2-8.2 MEMORY BACKUP There is no battery for you to install or replace. The microprocessor's internal power cell is rated for a life of 8-10 years.

2-9. USING MEMORY FEATURES: A BRIEF TUTORIAL (OPTIONAL) The following get-acquainted exercise is provided for those who like this kind of approach to learning a new system of any kind. If you perform the following steps, you'll gain a quick working familiarity with [VFO>M] [MS] [MT] and other keyboard and memory functions.

Tune to your favorite operating frequency and set desired mode and filter.

Press [VFO>M]. Notice two blanks in the center of the display and that "MEM." lights up.

Press [0] [0] and notice 3 beeps: one for each 0 and one to confirm entry. For now, your selected frequency and mode is stored in Memory No. 00.

We'll now enter more frequencies quickly.

Press [ENTER] [0] [2] [5] [ENTER] to display a frequency of 2.500.00 (MHz). Also, press [AM] mode and filter [6.0].

Press [VFO>M]. Instead of entering a Memory number, simply press [ENTER] while watching the display closely. 01 will flash briefly, indicating that this frequency is in Memory No. 01.

For each of the following entries, also choose [AM] mode and filter [6.0].

Press [ENTER] [5] [ENTER] to display a frequency of 5.000.00 MHz.

Press [VFO>M] [ENTER]

Press [ENTER] [1] [0] [ENTER] to display a frequency of 10.000.00 MHz.

Press [VFO>M] [ENTER]
Press [ENTER] [1] [5] [ENTER] to display
15.000.00 MHz.
Press [VFO>M] [ENTER]
Press [ENTER] [2] [0] [ENTER] to display
20.000.00 MHz.
Press [VFO>M] [ENTER]
Press [ENTER] [7] [3] [3] [5] [ENTER] to
display 7.335.00 MHz.
Press [VFO>M] [ENTER]

You have now placed 7 frequency selections in memory. If you'd like to add a few more of your own choice, do so now. (Remember that you can store mode and filter as well as frequency.) Otherwise, proceed with the following steps.

Tune in ANY station of interest to you which is NOT in memory. Press [MS] and rotate Main Tuning knob. Notice that you are scrolling through the memories without disturbing the signal tuned in. This scrolling function continues until you press [MS] again.

Now, press [MT] and again rotate Main Tuning knob slowly. This time, you are actually listening to the memory frequencies which you programmed. One of the several WWV frequencies should be quite strong. 7.335 MHz is the Canadian CHU time/frequency station at Ottawa. This Memory Tune function will continue until you press [MT] again.

For fun, press [DIS] as many times as needed in order to see the full six-digit time display. Press [SET], which displays "_____". Press [MT] and pick the strongest signal from WWV or CHU.

At the first voice announcement of current "Coordinated Universal Time," type in the first THREE digits of the time announced. The next announcement is one minute later. Poise yourself to press the final digit at the exact instant of the WWV or CHU tone. Then, watch how closely the display of seconds matches the transmitted pulses!

Now, press [SPD], which will display two digits in the range of 00 to 09 in place of the VFO frequency. Press [4], which sets a moderate rate for automatic memory scanning. (Do not try to press two numbers: the range is 0 to 9.) Press [SHIFT] [MT] and watch that all your memory entries are being scanned automatically. This function can be stopped by pressing [MT] again or by pressing [CLEAR].

Finally, use either [MS] or [MT] to scroll or tune your memories. When you reach Memory 00 (your favorite frequency programmed first), press [M>VFO] and see that the VFO now tunes around that frequency.

The preceding steps should give you a basic idea of how memory can be used to enhance your use and enjoyment of the PARAGON II.

2-10. SUMMARY The purpose of this chapter has been simply to help you GET STARTED in using your new PARAGON II through brief explanations of the Keyboard functions and initial settings of the other controls. Chapter 3 provides a more detailed look at ALL the functions and capabilities of the transceiver. When you have the time, reading Chapter 4's description of each circuit board will give you a good feel for the inner workings of your transceiver. All information about connecting the PARAGON II to a computer is contained in Chapter 5.

CHAPTER 3

DETAILED OPERATING INSTRUCTIONS

This chapter discusses each operating function, control, switch and connector on both front and rear panels of the PARAGON II. If you wish a simple description of each keyboard key, please refer back to Section 2-2.

3-1.1. CHANGING FREQUENCY. There are a total of SIX ways of moving to a different frequency or band:

1) Tune up or down a band by using the Main Tuning knob.

2) Move up or down a band quickly in 100 KHz steps (1 MHz steps is FAST is on) by using the [UP] and [DOWN] arrows on the number pad. (5 or 10 KHz steps on AM and FM).

3) Change from band to band by pressing the desired band button.

4) Change to the other band register frequency in the same band by pressing the same band button again.

5) Press [A/B] to change VFO's.

6) Move to a specific frequency by entering it directly from the number pad, using [ENTER] key.

3-1.2. DIRECT FREQUENCY ENTRY: BASIC USE AND SHORTCUTS. All direct entries are initiated by pressing [ENTER], which immediately displays a row of blanks for the VFO in use: _____. A frequency may be entered exactly or partially, depending on whether you wish a very specific frequency or a general range or band for tuning around. Examples:

[ENTER] [1] [1] [8] [4] [0] [ENTER] displays 11.840.00 MHz. However, entering the last 0 is optional.

[ENTER] [1] [1] [8] [ENTER] displays 11.800.00 MHz.

[ENTER] [1] [1] [ENTER] displays 11.000.00 MHz.

[ENTER] [1] [ENTER] displays 1.000.00 MHz.

[ENTER] always begins and ends the sequence unless you happen to have reason to enter the maximum of 7 digits for 10 Hz resolution.

To enter VLF or AM broadcast frequencies below 1 MHz, it is necessary to press [0] TWICE before entering one or more digits of the frequency. The first [0] will not be displayed, but pressing it will delete one of the blank lines of the display. The second [0] will be displayed. SEE FURTHER NOTE BELOW about direct entry of frequencies below 3 MHz.

[ENTER] [0] [0] [8] [4] [ENTER] displays 0.840.00 (840 kHz)

[ENTER] [0] [0] [1] [ENTER] displays 0.100.00 (100 kHz)

Notice that there is no decimal point on the number pad. All required decimals are generated by the display itself.

IMPORTANT NOTE: Any direct entry of MORE than one digit below 3.0 MHz must be preceded by [0]. While entering [1] will display 1.000.00 MHz, you must enter [0] [1] [8] to display 1.800.00 MHz. (Entering only [1] [8] will put the VFO at 18 MHz.) Above 3 MHz, the microprocessor interprets shortened entries as being in the 3.000 to 29.999 MHz range.

3-1.3. MODE SELECT KEYS. The most common modes are selected by simply pressing the correct key in the vertical row to the left of Main Tuning. The adjacent LED clearly indicates the mode in use. FM mode is a standard PARAGON II feature with no additional board to install. Special keyboard sequences select AM transmit and FSK modes.

3-1.4 TUNE Activates the transmitter in CW mode, key down. Power output is adjusted with

the RFPWR control. This mode is intended for setting output power, checking SWR and collector current (Ic), and adjusting antenna tuner or linear amplifier. FCC rules require station identification and the avoiding of interference to other stations when using TUNE mode.

[CW] selects CW mode, requiring that a key or keyer be connected to the KEY jack on the rear panel for transmit operation. All filters available are useable in CW mode. See 3-6.13. regarding QSK fast/slow selection and 3-8.1 regarding CW sidetone pitch and volume.

[USB] selects upper sideband mode which is the norm for amateur bands at 14 MHz and higher. While any of the filters can be selected, only [6.0], [2.4] and [1.8] are useable for SSB reception.

[LSB] selects lower sideband mode which is the norm for the 160, 75 and 40 meter amateur bands and also for AFSK transmit. Useable filters are the same as for USB when operating SSB, but all filters are useable for AFSK and other digital modes.

[AM] places the receiver in AM receiving mode. [6.0] is the filter primarily intended for AM reception. The PARAGON II also is capable of AM TRANSMIT, which requires that BOTH [AM] and [LSB] or [USB] be pressed at the same time. You are assured of being in AM transmit mode if both the AM LED and the USB or LSB LED are lit.

[FM] selects FM operation for use on 29.0 through 29.7 MHz, or on VHF bands when using a transverter or receiving converter. In FM mode, several transceiver functions are changed or taken over by the FM circuitry:

1) The [UP] and [DOWN] buttons move the VFO frequency in 5 KHz steps. For this channelized tuning to be useful, the VFO must first be tuned to a frequency such as 29.000.00 or 29.005.00. In [FAST] mode, these steps are 10 KHz.

2) The MIC control becomes an FM deviation control. Set MIC gain at 10:00 for proper +/-5 KHz deviation when using TEN-TEC mikes. You may find a slightly higher or lower setting is needed with other microphones.

3) IF filtering is provided by the FM circuitry. If modulated CW operation is desired in FM mode (authorized only for 29.0-29.7 MHz and VHF), feed a keyed sinewave tone to AUDIO IN phono jack on rear panel and use MIC gain control to adjust proper level.

3-1.5 FSK OPERATION. True frequency-shift-keying is a built-in feature of the PARAGON II and is selected by pressing [SHIFT] [CW] in sequence. FSK mode selection is confirmed by NO mode LED's being lit. The FSK circuitry is controlled through the rear panel MARK/SPACE phono jack. This input is typically connected to the FSK output of a modem or terminal unit. The logic levels required at the MARK/SPACE input are less than or equal to 1.0 VDC for MARK, and equal to or greater than 2.0 VDC for SPACE. This input includes its own pullup resistor with an open circuit voltage of about 3.5 VDC. Either a standard TTL level or open collector output line will drive the MARK/SPACE input. See also 3-9.13,14.

During receive, the FSK mode receives LSB, and all of the filters are useable. FSK RTTY is a specialized communications mode requiring further information about operating procedures and equipment connections which are beyond the scope of this transceiver manual.

3-1.6 USING THE FAST TUNING FUNCTION Pressing the [FAST] key affects both Main Tuning and the UP/DOWN keys, and its effects depend on Mode selection. In SSB, CW and FSK modes, the UP and DOWN keys move the frequency in 1 MHz steps rather than 100 KHz steps. In AM and FM modes, the normal steps are 5 KHz, and pressing [FAST] results in 10 KHz steps.

Main Tuning rates are charted below in KHz per revolution of the knob:

	<u>MODE</u>		
	CW,FSK	SSB	AM,FM
[FAST]OFF	1.2	4.8	24
[FAST]ON	9.6	9.6	48
[SHIFT][FAST]	240	240	240

3-1.7 ADJUSTING MAIN TUNING

KNOB It can be useful to know that the Main Tuning control is an optocoupler that is part of the digital circuitry, not a variable capacitor, inductor or potentiometer. The knob assembly itself is factory set for a smooth feel. If you wish to increase the "drag" of the knob, hold the rear silver skirt firmly and turn the knob clockwise to tighten, or the other way to loosen. If the knob appears to "wobble", the rear skirt can be moved slightly from one side to the other to make the knob concentric.

3-2.1. DIGITAL COMMUNICATIONS

BASICS Virtually all available digital systems include an AFSK (audio frequency shift keying) generator intended to be connected to the microphone input of a transceiver using SSB or FM mode. A further connection is made to the AUDIO OUT circuit. Correct operation of packet and other digital systems requires a thorough understanding of the equipment, interconnections and procedures as explained in the digital device's instruction manual and other literature specializing in those modes.

3-2.2. USING PARAGON II IN DIGITAL

COMMUNICATIONS. In addition to amateur band digital communications or monitoring, the PARAGON II's general coverage lets you listen to (or see!) a wide variety of digital communications. Simply connect the terminal hardware to the AUDIO OUT rear panel jack and follow the equipment's instructions. For amateur band communications, please be aware of the following:

1) The AUDIO IN rear panel phono jack is the same line as on the front MIC connector. Be sure that the microphone itself is turned off during digital operations.

2) The MIC gain control is used to adjust proper AFSK level. With the RF PWR control turned all the way back (CCW), transmit a string of text such as RYRYRYRY. Adjust the MIC control so that the ALC LED barely blinks. Then advance RF PWR control to the desired RF power output level.

Follow the above procedure exactly, because too much AFSK audio will overdrive the transmitter and generate phantom signals.

3) NEVER use Speech Processing for digital AFSK operation.

4) Use the PTT phono jack to control digital operations. The VOX system is not fast enough, particularly for AMTOR mode.

5) Operate in LSB mode and be sure you understand the purpose of any sideband reverse switching provided in the digital terminal unit.

3-3.1. I-F CRYSTAL FILTER SELEC-

TION. The transceiver is equipped with 6.0 and 2.4 KHz bandwidth filters. Optional filters for 1.8, .5 and .25 kHz may be ordered from TEN-TEC and installed easily by you. LED's above each filter key clearly show which filter is selected, but be aware that these LED's light regardless of whether the filter is actually installed.

3-3.2. CLOCK. The clock display is provided with the option of using it or not using it, depending on operator preference. The [DIS] key toggles from full display with readout of seconds, to a simpler 4-digit 24-hour display, to turning the display OFF (which does not interfere with actual clock running). The [SET] key is quite easy to use: when you see "____", just enter the desired time in 4 digits, and the clock immediately begins to count after the 4th digit entered.

3-3.3. 10-MINUTE ID TIMER Included at the request of many operators, this user-selected function sounds a keyboard "beep" every 10 minutes in consideration of classic FCC

station ID requirements. Turn this feature ON by pressing [SHIFT] [DIS]. To reset and begin a new 10-minute interval, press [DIS] three times, which also will return to your original clock setting. Turn this function off by pressing [SHIFT] [DIS] again.

3-4.1. SIMPLEX OPERATION is the most common HF operating configuration and merely means that all stations in communication with each other are on the same frequency and mode, some perhaps using minor RIT adjustments. This "obvious" definition is useful because many operators are accustomed to VHF duplex operation and because the PARAGON II offers several methods of controlling receiver and transmitter independently for flexibility in DX, net and emergency communications. In fact, you have at your fingertips the equivalent of several pairs of transmitters and receivers.

3-4.2. "SPLIT" VFO OPERATION. Pressing the [SPLIT] key instantly simulates the traditional setup of completely separate receiver and transmitter, controlled respectively by VFO A and VFO B. The Split feature is ordinarily used when working DX contacts or 10 Meter FM Repeater operation (or VHF work with transverters.)

"Split" mode is clearly indicated in the display section, and pressing [SPLIT] again will turn off this mode. Any Split setup can be stored in memory for convenient recall. Simply make sure the Split is set up the way you want it when you press [VFO>M]. See 3-5.3.

3-4.3. UNDERSTANDING RIT/XIT. It is common for even simple transceivers to provide a few KHz of RIT (receiver incremental tuning), also called Offset Tuning, which permits adjustment of the received frequency without disturbing the transmit frequency. The PARAGON II provides extended offset tuning of +/- 99.9 KHz for receive (RIT), or

transmit (XIT), or both simultaneously, as explained in the following sections.

RIT/XIT is tuned by the Main Tuning knob and is shown in the center of the display as KHz above (+) or below (-) the VFO frequency. The amount of offset tuned will be retained in memory even after [RIT] or [XIT] keys are pressed to turn off the feature. If desired, the offset may be cleared instantly (returned to 00.00 KHz) by pressing [CLEAR] while RIT or XIT mode is on.

The main VFO display can be changed to include the amount of RIT/XIT by pressing [SHIFT][RIT]. Exercise caution if you select this display option as the actual TX frequency is not immediately obvious when viewing the displays.

3-4.4. RIT/XIT AND MEMORY. A frequency may be stored in the scratchpad or in permanent memory WITH any desired RIT or XIT setting. If you change bands without turning RIT or XIT off, that RIT or XIT setting will be active when you return to that band.

3-4.5. RIT OPERATION is used primarily by stations which initiate CQ's and need to fine-tune multiple replies or listen "up 5," etc. Press [RIT] once to turn on this feature, then use Main Tuning knob to tune receiver while transmitter remains at the displayed VFO frequency. Use RIT in ANY situation in which you wish to adjust receiver without disturbing the transmit frequency.

3-4.6. XIT OPERATION is initiated by pressing [XIT] once, then using Main Tuning to move your transmit frequency to the offset desired. This is very handy for complying with DX requests to call "up 5" and so forth. While in XIT mode, you continue to receive on the VFO frequency. Pressing and holding the [REV] key lets you listen on the actual offset frequency to make sure you are not zero-beat with dozens of other stations.

3-4.7. SIMULTANEOUS RIT/XIT When both functions are activated, you are operating simplex at the offset displayed. The Main Tuning knob sets the transceiver frequency to the displayed offset, not the main frequency display. This seems redundant but there is a good application. For example, you are running your own pile-up in a contest using RIT. Another station calls CQ 1 KHz above your transmit frequency. Tune in the station, using RIT. Press XIT. You are now simplex on the interfering station. Ask him to QSY and press XIT off. Your station is now back at your original transmit frequency.

3-4.8. VFO A/B is a commonplace transceiver feature which you can customize to suit your particular operating preferences. Each VFO retains its last-used frequency, mode and filter. Pressing [A/B] toggles (switches) between VFOs, and the VFO in use is clearly identified in the display. Pressing [A=B] makes the other VFO identical to the frequency, mode and filter of the VFO currently in use and displayed. Pressing [SPLIT] keeps the current VFO for receiving and uses the other VFO.

3-4.9. CROSS BAND OPERATION is possible on SSB only. These splits can be programmed with one band in VFO A and the other in VFO B. Receive/transmit switching time will be delayed. You must use PTT (not VOX) on SSB.

3-5.0. THE MEMORY SYSTEM. The PARAGON II provides a total of 6 kinds of memory:

- One scratch pad memory
- Band register for each amateur band
- 60 general purpose memories (00-59)
- Programmable Scan Plus:
- Last-used settings of other VFO
- Last-used settings while power is turned off.

Each type of memory (except 60-61) stores

frequency, mode, filter and any use of split, RIT or XIT. This section (3.5) explains the various ways to use and manage memory.

3-5.1. USING THE "SCRATCH PAD" The purpose of this memory feature is to permit quick, temporary storage of the current frequency (and mode, etc.) so that you can tune around or consider permanent storage later. First, make sure that [MS] and [MT] are off. Press [VFO>M] TWICE. "SP" and the "MEM" light will flash in the display to confirm data is stored. To recall this data, press [M>VFO] twice, and it will be entered on the active VFO.

3-5.2. BAND REGISTERS. There is one band register for each of the nine amateur bands. It provides a method of quickly switching between two frequencies on the same band. Tune VFO to a desired frequency. Press the band button of the same band. Tune VFO to a second frequency of interest. Press the band button again and notice that the VFO returns to the first frequency. Each time the band button is pressed, the two frequencies will exchange. When you change from that band, the two most-recently tuned frequencies (with mode and filter) will be retained.

3-5.3. MEMORY STORE. This procedure uses the [VFO>M] key to transfer the current VFO frequency, mode, filter, and any setting of split, RIT or XIT into one of the 60 memory channels. Press [VFO>M] once and see that " _ _" and MEM. appear in the center of the display. Entering a channel number from 00 to 59 will replace that channel with the new information. Therefore it is useful to maintain a chart of memory setups that are important to you. The entry is automatic as soon as you press the two digits from the number pad. If you do not want to risk overwriting another channel or assigning a particular number, simply press [ENTER] when you see " _ _", and the information will be stored in the next unused

channel.

Memory channels 60 and 61 are used only to store upper/lower limit frequencies for programmable scanning.

3-5.4. "MEMORY FULL" If all 62 memory channels are in use, the display will read "FULL". Use the Memory Scroll or Memory Tune or your written chart to select channel(s) that you are willing to change. Then press [VFO>M] and enter the two digits of the channel number you wish to replace with the current VFO information. Additional channels can be cleared for future use simply by displaying them using Memory Tune or Memory Scroll and pressing [CLEAR] at each channel that you wish to empty.

3-5.5. MEMORY RECALL BY CHANNEL NUMBER. Press [M>VFO] to display " _ _ ", type in the desired channel number (00 to 59) and press [ENTER]. The data in that memory channel will transfer to the active VFO.

3-5.6. USING MEMORY SCROLL. Press [MS] and note that its LED comes on. Use the Main Tuning knob to scroll through all channels which contain information. The receiver will remain as set before [MS] was pressed. To cancel scrolling, press [MS] again and note that the LED goes out. To enter a displayed memory into the active VFO during memory scroll, press [M>VFO] while displaying the channel of interest.

3-5.7. MEMORY TUNE. This function differs from Memory Scroll in that each frequency displayed is useable for listening or even for transceiving while in Memory Tune mode. Press [MT] and tune through the channels with Main Tuning. Pressing [MT] again cancels the function. While each memory channel is useable or active, there can be no fine-tuning or use of RIT/XIT. The better procedure for using a

memory channel is to press [M>VFO], which places it in the active VFO and cancels Memory Tune.

3-5.8. SCANNING SPEED. The PARAGON II offers both frequency scanning and Automatic Tuning (scanning) of the 60 separate memories. The rate of these automatic functions is set by the [SPD] key. Pressing this key replaces the VFO frequency with "RATE 04" or any other of ten two-digit steps from 00 (slowest) to 09 (fastest rate). A rate of 04 or 05 is good for initial tests. The rate is entered as a SINGLE digit from 0 to 9.

3-5.9. AUTOMATIC MEMORY TUNE. This feature permits automatic tuning or scanning of memory channels at a speed determined by the [SPD] key. First, set the speed or rate as explained in 3-5.7. Then, simply press [SHIFT] [MT], and automatic memory tuning will operate until you press [MT] or virtually ANY key.

NOTE: Pressing [M>VFO] during automatic memory scan will transfer the currently-displayed memory channel to the active VFO, if desired.

3-5.10. PROGRAMMABLE SCAN is a feature with many practical applications for both the amateur band and general coverage capabilities of the PARAGON II. The speed or rate of the scanning cycles is determined by the [SPD] key as explained in 3-5.7. However, scanning is also affected by the [FAST] key, which changes the amount of frequency change per scanning cycle, depending on the mode selected.

1) Scanning is initiated by pressing the [PS] key but requires prior entries into Memories 60 and 61, and desired settings of [SPD] and [FAST] functions.

2) To carry out scanning routines, the [PS]

command requires the setting of LOWER AND UPPER SCAN LIMITS, which are entered into Memories 60 and 61.

3) Holding "scan limits" is the only function of Memories 60 and 61 in the PARAGON II's 62-Memory system. Tune the VFO to LOW limit of desired scanning and use [VFO>M] to enter it into Memory 60. Similarly, enter the upper limit into Memory 61.

4) Use [SPD] key to set the rate or speed of scanning. 00 is very slow, about 10 seconds, while 09 is the fastest rate, best understood by experimenting.

5) EXAMPLE: You are busy with other matters in early morning but wish to hear when 17 Meters starts to open up in any mode. Set VFO to 18.068 and use [VFO>M] to place that frequency in Memory 60. Tune to 18.168 and use [VFO>M] to enter that setting into Memory 61. Then, press [PS], and scanning will begin between the two limits that you set.

6) For CW/SSB at normal tuning/scanning speed ([FAST] off), scanning will be in 200 Hz increments at the rate set by [SPD] function. If you press [FAST] before pressing [PS], scanning will move along in 1 KHz increments.

7) Scanning in AM or FM modes will be in 5 KHz steps (normal) or 10 KHz with [FAST] turned on.

8) NO CHANGES can be made during scan operation. To change mode or to use [FAST], press [PS] to stop scanning.

9) The frequencies placed into Memories 60 and 61 are outer limits and are not tuned in during scanning operation.

3-5.11. OTHER KEYBOARD FEATURES.
The operation of the PARAGON II keyboard

has been discussed with a focus on actual use of operating features. If you still wonder about the use of a specific key, a review of Section 2-2 and the Table of Contents may be helpful.

3-6.0. OTHER FRONT PANEL CONTROLS. This section (3-6) will discuss the operation of PARAGON II front panel controls which are not part of the keyboard covered in 3-1 through 3-5.

3-6.1. RF OUTPUT POWER is adjusted with the RF PWR control and observed on the second meter scale with meter switch set to FWD. If full clockwise setting does not result in 100 watts indicated output, switch the meter to Ic collector current and adjust RF PWR so that Ic does not exceed 20 amps. To make these measurements and adjustments, press [TUNE] to key transmitter in CW mode.

3-6.2. FORWARD AND REFLECTED POWER. Anytime that 100 watts FWD is not available, the most likely cause is SWR that exceeds 2:1. Set meter switch to REF and check SWR scale. The circuitry protects the transmitter from damage, but maximum output power will require a better SWR by using an antenna tuner or modifying the antenna system.

3-6.3. MIC GAIN. Using either PTT or VOX, speak into your microphone at normal operating voice level and adjust MIC gain control so that the ALC light just blinks on voice peaks.

3-6.4. SPEECH PROCESSOR USE. A green LED clearly shows when Processor is turned on. Turn meter switch to PROC. While speaking into microphone at normal operating voice level, adjust PROCESSOR control until voice peaks are in the heavy black line range on the bottom PROC scale of the meter. Now, recheck the MIC gain setting and readjust as needed for ALC light blinks on voice peaks. See also 3-8.2. about using the rear panel

The next best thing to a Ten-Tec transceiver...



HIGH POWER TUNER

Superior matching capability with an L-network tuner assures correct match every time. 2000 watts CW or SSB PEP power rating. ARRL rated as the lowest insertion loss tuner available, QST February 2003. 3 year parts/labor warranty. **\$649**



715 RF SPEECH PROCESSOR

High performance true RF-type speech processor. RF speech processing is a superior system to the processor found in a typical HF transceiver for achieving the highest ratio of average-to-peak power from SSB transmitters. **\$249**



302R REMOTE ENCODER/KEYPAD

Armchair tuning and direct frequency entry for your Omni-VII, Orion/Orion II, and Jupiter HF transceiver. Function buttons allow control of some radio features. **\$139**



CENTURION LINEAR AMPLIFIER

In its 20th year, this proven dual 3-500ZG design busts the pileups but won't bust your wallet. Peak reading wattmeter and QSK standard. Easy to use and tune up. **\$3195**



963 POWER SUPPLY

Hash-free switching design. 13.8 Vdc at 25 amps continuous, 30 amps peak. Small, lightweight (4 lbs!), 90-264 VAC, 50/60 Hz input make 963 usable from just about anywhere. **\$169**



310 FAN KIT

Hole-free allen screw attachment to transceiver heat sink. 13.8 Vdc powered. Use with Orion/Orion II, all Omni, Paragon, Jupiter, Pegasus, Corsairs, Tritons. **\$39.95**



TAPR VECTOR NETWORK ANALYZER

Use it to test low power amplifiers, characteristics of coax cables, measure and adjust filters, check antenna impedance vs. frequency, antenna SWR, even measure the length of transmission lines using TDR feature. **\$655**



307B SPEAKER

External front-firing communication speaker, black cosmetics match current Ten-Tec HF transceivers. Cabinet and large 4-inch speaker designed specifically for Amateur Radio use. **\$98**

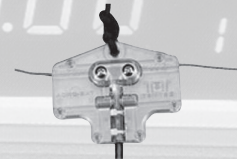

3003 ACRO-BAT ANTENNA HANGER

Unbreakable polycarbonate. Not affected by UV. Ladder line or RG58/RG8X coax fed antennas. **\$9.95**. Save with a discount 4 pack for only **\$32!**

...is a Ten-Tec accessory!



709/709A MICROPHONE, 711 STAND

Omni-directional dynamic microphone for Amateur Radio and other transmitting applications. Die-cast zinc shell, slider PTT switch, cable. 30 Hz to 12 kHz frequency response. **\$69**. 711 stand for 709/709A, **\$15**



708/708A DELUXE DESK MIC

Omni-directional dynamic microphone for Amateur Radio and other transmitting applications. 3 position PTT switch with TX, OFF, and LOCK, flexible metal gooseneck, ball-type element housing. 30 Hz to 12 kHz frequency response. **\$99**



316 USB/SERIAL CONVERTER

For communicating with serial-equipped devices like Ten-Tec HF transceivers from PC's that have only USB ports. Converter and drivers included. **\$19.95**

www.tentec.com



The SSB Company

1185 Dolly Parton Pkwy., Sevierville, TN 37862. Sales: 800-833-7373 M-F 8:00-5:30 (Eastern Time) sales@tentec.com. Office: (865) 453-7172. FAX: (865) 428-4483. Service: (865) 428-0364 M-F 8:00-5:00 (Eastern Time), service@tentec.com. We accept Visa, MC, American Express and Discover.

MONITOR LEVEL control with headphones for actually checking audio quality. Do not leave the **METER** switch in **PROC.** position while in operation.

3-6.5. RECEIVER ATTENUATOR. The **ATTN** switch attenuates the receiver -20 dB, which may be useful when using the receiver to test other equipment. Because of the outstanding selectivity and dynamic range of this receiver, it is unlikely you will need **ATTN** for normal operation.

3-6.6. NOISE BLANKER. This noise blanker circuit is designed to cancel or reduce pulse noise such as engine ignition, power lines or noise from common household appliances. When such noise is present, push **N.B.** switch on, and adjust **N.B. WIDTH** control for minimum interference.

3-6.7. AGC ON/OFF. The function of **AGC** (automatic gain control) is to maintain a relatively constant audio level over a wide range of actual received signal levels. The **AGC "off"** option is provided because some operators feel that there is better intelligibility with **AGC off**, full **AF** gain, and using **RF** gain as a volume control. If you use this setup, be sure to keep one hand on the **RF** gain control, because any sudden strong signal will be **VERY** loud! The normal setup is to keep **AGC** on, **RF** gain fully clockwise, and to use **AF** gain for volume control. Remember, too, that **S-meter** operation requires **AGC** on and **RF** gain at full.

3-6.8. AGC FAST/SLOW This switch selects the attack and decay speeds of the **AGC** circuit. As a general rule, use **FAST** **AGC** on key-down modes such as **RTTY** and **FM**, as well as weak **SSB** and **CW** signals. Use **SLOW** **AGC** on strong **SSB** and **CW** signals.

3-6.9. USING THE S-METER. The meter is always in **S-Meter** mode during receive, re-

gardless of meter switch settings. However, **AGC** must be **ON** for **S-meter** operation, and **RF** gain must be fully clockwise for accuracy. Due to the receiver's excellent characteristics, signals in the **S5-S7** range will seem deserving of "**S9+**".

3-6.10. AUDIO (AF) AND TONE CONTROLS As a rule, the **RF** gain control is kept at its maximum (clockwise) setting for maximum sensitivity and accurate **S-meter** operation. The **AF** gain control is used for audio volume adjustments. The **TONE** control is provided primarily for shortwave broadcast listening but may be set to personal preference in any mode.

3-6.11. RF GAIN AND SQUELCH. The use of the **RF** gain control has been mentioned in 3-6.7,9,10. It is normally set fully clockwise, which is required for correct **S-meter** operation. The **SQL** (squelch) control is active only in **FM** mode. Tune to a clear, unoccupied frequency and adjust **SQL** just into the threshold for receiver quieting, just as with any **FM** handheld or scanner.

3-6.12. PTT/VOX SWITCH. This switch selects between **PTT** (push to talk) and **VOX** (voice operated) operation. The **PTT** line is available at both pin 3 of the front **MIC** jack and the rear panel **PTT** phono jack. The three controls for adjusting **VOX** operation are on the rear panel and are discussed in Section 3.8.

3-6.13. QSK FAST/SLOW. This switch selects the speed at which the transceiver switches between transmit and receive. **QSK FAST** is normally used for full break-in **CW** and for operation on **AMTOR** using **FSK** mode. **QSK SLOW** is primarily for **CW** operation in the presence of high **QRM/QRN** levels.

3-6.14. MIC CONNECTOR. This 4-pin microphone jack is wired as follows:

pin 1 = microphone
pin 2 = ground
pin 3 = PTT line
pin 4 = +4 volts DC

Any TEN-TEC or T-KIT microphone may be used without modification. See Section 1-3 regarding other microphones. The microphone and PTT lines are common to the AF IN and PTT phono jacks on the rear panel. The DC voltage at pin 4 is for use with electrets or other microphones requiring a supply voltage.

3-6.15. PHONES JACK. This 1/4" jack is a closed-circuit STEREO jack wired for monaural operation, permitting the use of stereo as well as mono headphones. The circuit is designed for 4-16 ohm impedance, but 600-ohm communications-grade headphones also may be used.

3-7.0. UNDERSTANDING THE SELECTIVITY SYSTEM In general, you will learn the effectiveness of the Selectivity controls and IF filters through hands-on experience. In addition to the filter selection keys on the keyboard, receiver selectivity is controlled by:

- FADE (Bandpass Fade)
- BP (Bandpass Tune)
- PBT (Pass Band Tuning)
- NOTCH (-40 dB Carrier Reduction)

3-7.1 BP/FADE. The receive audio response can be adjusted using the BP and FADE controls. If the FADE control is fully counter-clockwise the audio frequency response is flat and the BP control will have no effect.

As the FADE control is turned clockwise the audio response shifts from flat to bandpass filtered. The selectivity of the filtering increases as the FADE control is advanced. In this position the BP control adjusts the center frequency of the bandpass response.

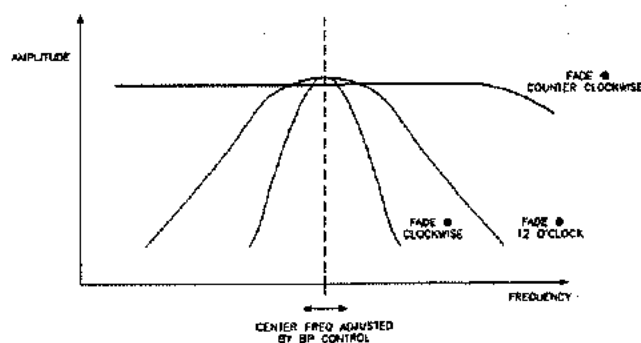

3-7.2. PBT / NOTCH. The PBT control adjusts the position of the PBT IF crystal filter in relation to the fixed second IF filter. When the selected filter is wide, i.e. 6.0, 2.4 or 1.8 kHz, the PBT control essentially becomes a variable bandwidth control. Turning PBT counter-clockwise when in USB mode shifts the passband toward the low side of the signal. Turning clockwise shifts the passband toward the high side. These effects are reversed in LSB mode.

The PBT circuit has the effect of varying the frequency response of signals passing through the narrow filters, which enables you to separate signals which are close together. In RTTY mode, it can place the narrow filter to pass only the 2295 Hz and 2125 Hz tones for superior rejection of adjacent signals. The PBT system has no effect on the transmitter frequency or bandwidth.

The NOTCH control adjusts the center frequency of the audio notch across the passband. The notch depth is at least 40 dB and will reduce carrier interference by this amount or more. To use the NOTCH control, rotate it SLOWLY until the unwanted signal is reduced as much as possible. The notch circuit is effectively turned off when the control is turned fully counter-clockwise.

3-8.0. REAR PANEL ADJUSTMENTS The controls on the rear panel are generally "set and forget" adjustments based on operating preferences.

3-8.1. SIDETONE CONTROLS. Both the pitch and volume of the CW sidetone are set to personal preference by the **PITCH** and **LEVEL** controls. Sidetone volume is independent of the front panel **AF** gain.

3-8.2. MONITOR LEVEL. This control is effectively **OFF** when turned fully counter-clockwise. Turning it clockwise permits monitoring of **SSB**, **AM** or **FM** transmit audio, which is done best with headphones to prevent feedback. It is especially useful when first learning to adjust the **PROCESSOR** control to avoid distortion. Also, it is useful for checking **AFSK** and **SSTV** signals. Turn the **MONITOR LEVEL** control off (counter-clockwise) during normal speaker operation.

3-8.3. BEEP/VOICE. This control adjusts the volume of both the keyboard beep and the optional voice annunciator to your personal preference. The keyboard beep is quite useful to confirm actual entry.

3-8.4. VOX CONTROLS. Selection of **VOX** or **PTT** operation is made from the front panel switch. The rear panel adjustments are made once or only occasionally as follows:

1) With front panel **RF** gain fully clockwise, and speaker and mike both in their normal locations, adjust **AF** gain to a comfortable listening gain. Also, remember to select **VOX** mode rather than **PTT** on both the transceiver and any microphone with such switching.

2) Starting with **VOX GAIN** fully counter-clockwise, speak normally into the microphone until there is reliable **VOX** action.

3) Adjust **DELAY** so that **T/R** switching is smooth, not occurring between words while speaking.

4) Set **ANTI VOX** to the point where receiver audio does not trip the **VOX** circuit at moderate levels.

3-8.5. MAIN/AUX ANTENNA SWITCH. This switch permits selection of an alternate **RECEIVE** (only) antenna connected to the phono jack above this switch. Switching antennas for receiving does not affect transmit, and the second antenna may be left connected at all times.

3-9.0. REAR PANEL CONNECTORS While most of the connectors are self-explanatory, remember that it is essential to understand the purpose and operation of any accessory equipment connected to the **PARAGON II** transceiver.

3-9.1. AUX RX ANTENNA This jack, switched in by the slide switch below it (see 3-8.5) permits the use of a separate receiving antenna such as a low noise loop for the low frequencies.

3-9.2. 50-OHM ANTENNA Consult the other sections in this manual for details about antenna, **RF PWR** adjustment, **SWR**, etc.

3-9.3. POWER Consult Chapter 1 regarding all details of using this 4-pin **DC** Power Supply connector.

3-9.4. FUSE Replace only with **25A** type **AGC** fuse.

3-9.5. GND See Chapter 1 for explanation of options for station ground and dealing with **RFI** or marginal grounding situations.

3-9.6. INTERFACE PORT This 25-pin "**D**" connector allows direct **RS-232** interface with a personal computer. See Chapter 5 for pin

assignments and other interfacing information. This Port is quite similar to the OMNI VI interface port and different from the "RS232 Interface" connector on the earlier model 585 PARAGON. This port operates at 1200 baud.

3-9.7. SERIAL PORT This 1/8" jack allows 2-wire computer control through a serial level converter such as TEN-TEC Model 305. See Chapter 5 for additional information.

3-9.8. EXT SPKR This 1/4" jack supplies full audio output to an external speaker rated a 4-16 ohms. The level is controlled by front panel AF gain. The internal speaker is muted when a 1/4" plug is inserted.

3-9.9. AUDIO OUT This jack provides FIXED LEVEL 1 mW audio, 600 ohms, for use with digital mode equipment, phone patch or similar accessories.

3-9.10 AUDIO IN This jack is the same line as the microphone pin of the front panel MIC connector. Input level is controlled by front panel MIC gain.

3-9.11. PTT This jack is the same line as the PTT line of the front panel MIC connector. It is provided for convenient hookup of digital mode accessories and also may be used for other manual T/R methods such as a foot switch. This line switches from receive to transmit whenever it is switched to chassis ground.

NOTE: The PTT line CANNOT be used for manual T/R operation in CW mode. Any attempt to switch the PTT line while in CW mode will key the transmitter in CW mode.

3-9.12. KEY This jack is for connection of a manual CW key, electronic keyer, or the CW keying output from a computer peripheral.

3-9.13. RTTY KEY This jack is in parallel with the adjacent KEY jack and used to switch to transmit for FSK operation. However, it does NOT operate the sidetone circuit.

3-9.14. MARK/SPACE This is the input for FSK RTTY keying. The MARK level can be 0 to -15 VDC. The SPACE level should be between +2.5 and +15 VDC.

3-9.15. AUX. +13.5V This jack may be used to supply 13.5 VDC up to 2 amps for accessories such as terminal unit, keyer, and so forth.

3-9.16. RELAY (N.O.) This output is used to control a non-QSK RF amplifier requiring heavy relay switching capability. The relay contacts switch to ground during transmit. NEVER use this relay output to control AC voltage. When operating CW, a drop-out delay is part of the relay circuit. The delay time is factory-set to an average value and may be adjusted via a trimmer potentiometer on the Control Board. There is no delay in the other modes.

3-9.17. TX OUT / TN EN The transceiver is supplied with a jumper device across these two jacks. Leave this jumper in place for all PARAGON II operations not using an RF linear amplifier. If you are using a TEN-TEC amplifier, consult interconnection information for both the transceiver and amplifier regarding the proper use of these two jacks.

3-9.18. XVRTEN/XVRT OUT These jacks provide easy use of TRANSVERTERS, which convert both receive and transmit to some band beyond the normal range of the PARAGON II, typically VHF/UHF. XVRTENable switches the very low level transmit carrier (about 0 dBm) to the XVRT OUT jack while also disabling the final RF transmit amplifier. This low level RF output is fed to the input of the

transverter, and the transverter receive output can be connected to the AUX RX jack (see note below and also 3-8.5 and 3-9.1). Typically, the 10 meter amateur band (28-29.7 MHz) is used for VHF/UHF transverter operation.

NOTE: If you wish to use only a Receive Converter, which uses the PARAGON II as a "tuneable IF" to receive VHF bands such as 6 Meters, etc., simply connect the converter's output to the AUX RX antenna jack, and use the MAIN/AUX Antenna switch (see 3-8.5) to choose between VHF reception and normal HF transceiver operation.

CONCLUSION: This chapter provides reasonable detail on the functions of all PARAGON II controls and connections, while presuming that you have studied or will refer back to the information in Chapters 1 and 2. Circuit descriptions and basic servicing information are provided in Chapter 4, and all details of transceiver-computer interfacing are in Chapter 5.

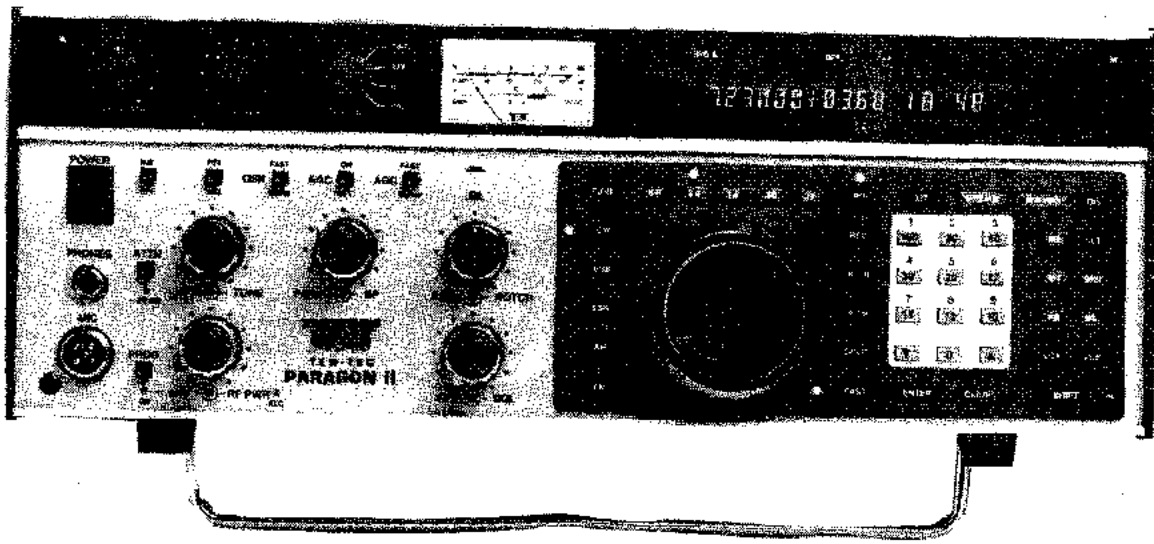

FIGURE 3-1. MODEL 586 FRONT VIEW

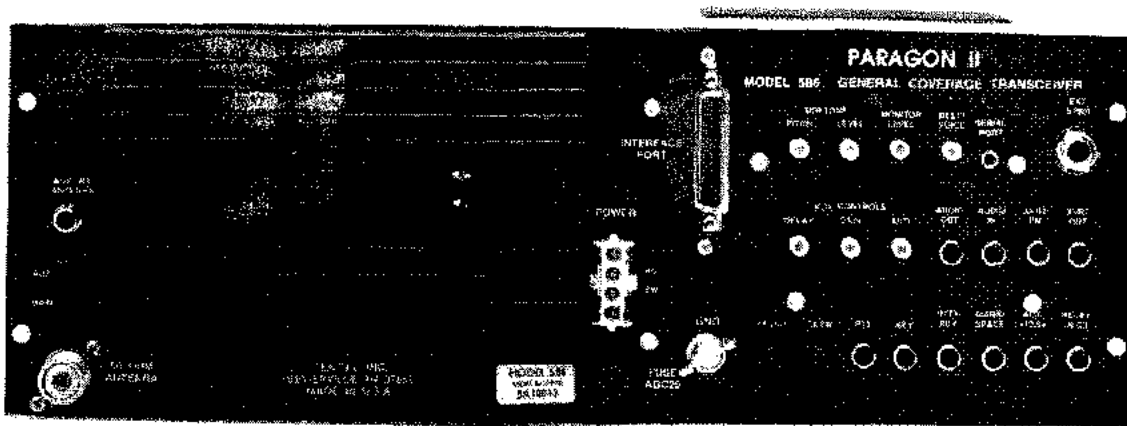

FIGURE 3-2. MODEL 586 REAR VIEW

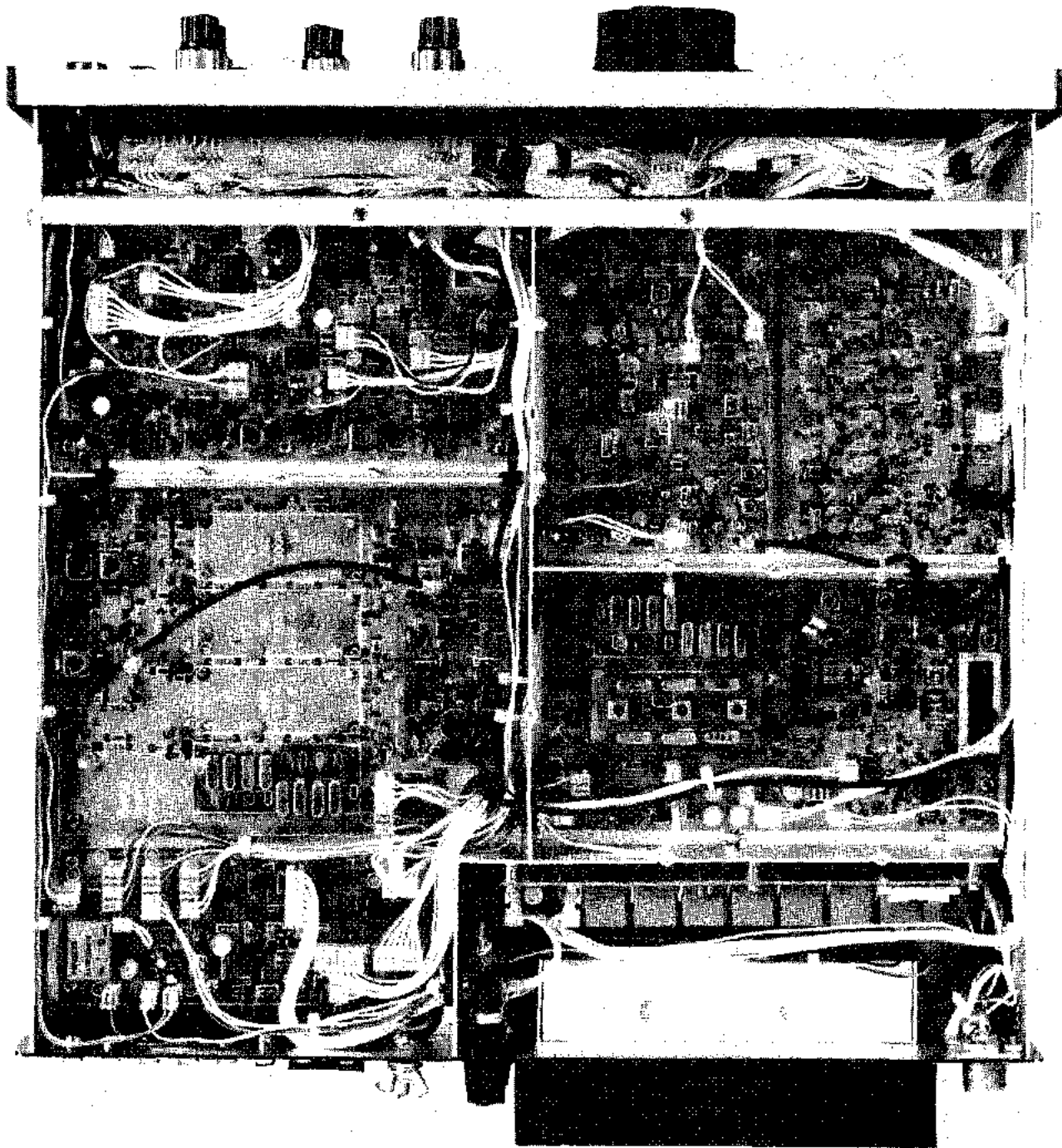

FIGURE 3-3. MODEL 586 TOP VIEW

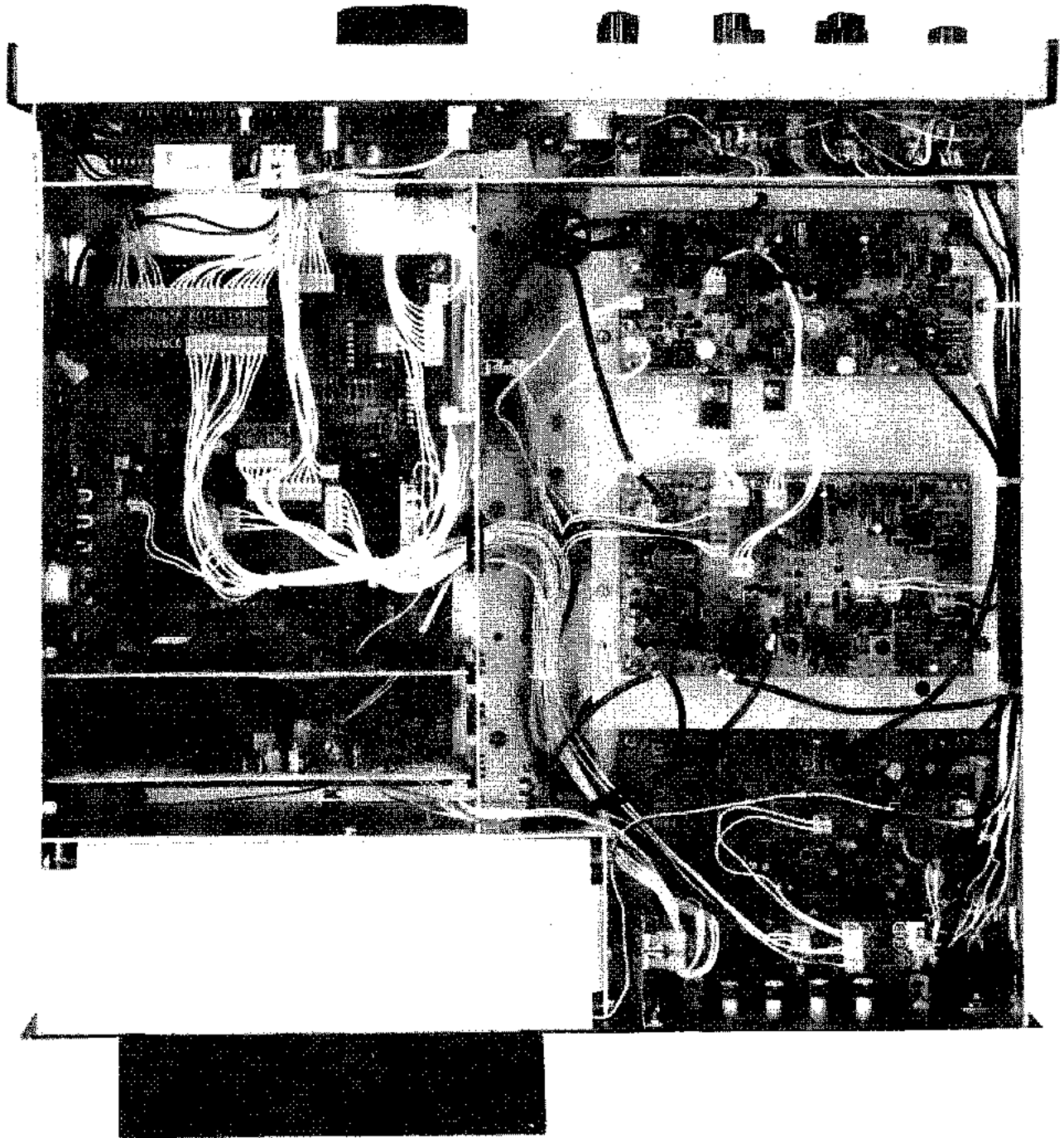

FIGURE 3-4 MODEL 586 BOTTOM VIEW

CHAPTER 4

CIRCUIT DESCRIPTIONS AND ILLUSTRATIONS

4-1. INTRODUCTION The following sections contain detailed circuit descriptions for all of the printed circuit board modules used in the PARAGON II. Also included are pictures of the modules with selected components identified. These drawings are followed by schematic diagrams.

4-2. LOGIC BOARD (81267-1)

This board contains the main system microprocessor, several I/O driver integrated circuits, address decoders and latches, three edge card connectors for expansion boards, and the rotary encoder circuitry.

The main microprocessor, U8, is the heart of the system. This is an 8-bit CMOS microprocessor with sixteen I/O lines and multiplexed address/data bus (B0-B7 and A8-A12) capable of addressing up to 8K of external memory. This microprocessor contains an internal oscillator whose frequency is controlled by Y1. The I/O lines going to connector 84 are used to control the PLL synthesizer circuits. Connector L is used to select the correct VCO in the PLL synthesizer, depending on the operating frequency of the PARAGON II. On connector 66, U8 monitors the KEY IN line to tell when it should go into the transmit mode. When KEY IN goes high, U8 will compute the correct transmit frequency and insert any needed timing delays before enabling the transmitter output by setting TX EN high. The IRQ line is used by the Real Time Clock circuit located on the RAM-ROM-RTC Board, and by the encoder circuits to tell the microprocessor to change frequency. The clock pulse from the encoder circuits is coupled by C13 to the IRQ pin. Pin PA0 of U8 is used to tell whether the encoder is tuning up (high) or down (low).

Twenty-four additional I/O lines are provided by U7 directly controlled by the main microprocessor. Whenever the CE (pin 21) of U7 goes low, U7 is enabled by the main microprocessor. This signal is generated by the address decoder on the RAM-ROM-RTC Board whenever the microprocessor addresses memory locations C2H - C8H. The I/O lines going to

connector 91 are used as input lines from the key matrix of the Keypad. The lines going to connector D are used to interface with the microprocessor on the VF Display Control Board. Pin PE4 of U7 is used to select the frequencies of operation allowed on the PARAGON II. When this line is jumpered to ground, the PARAGON II will transmit only on the ham bands. If this jumper is removed, the PARAGON II will transmit on any frequency from 1.7 MHz to 30 MHz. Pin PC7 of U7 is used to handshake with the optional Model 257 Voice Readout. The outputs at connector J go to U6 and are used in the keypad scanning routine.

U6 is a 1 of ten decoder which is used to scan the columns of the Keypad matrix. It is controlled by the signals coming from U7 via a jumper cable at connector J. The outputs of U6 go to connectors 94 and 97, which in turn go to the keypad.

Pins PB0-PB2 of U8 are used to send serial data to U1, a 32 bit latched driver. The outputs of U1 at connector K are used to select the correct low pass filter circuits, depending on the operating frequency of the PARAGON II. Output lines going to connector 59 are used to select the desired operating mode on the Control Board. Outputs from connector 92 drive the corresponding LEDs on the keypad. Outputs from connector 41 are used to select the desired crystal filter position while the corresponding LEDs are driven by the lines going to connector 95. Other outputs from connector 95, as well as connectors 96 and A are used to drive additional LEDs on the keypad. The outputs of connectors 98 and 99 are used to drive the LEDs on the VF Display Board.

U12 and diodes D1-D7 are used as an address decoder whose outputs go to the RAM-ROM-RTC Board.

U10 and U11 form another address de-

coder used to generate the DISP IRQ(enable) signal for U1 on the VF Display Control Board. The output of U10C goes low whenever U8 addresses A0H and the data strobe (DS) is high. In addition, the output of U11C goes high and serves to latch the required data into U9 (an 8 bit latch) which sends it to the display controller.

The encoder circuitry consists of an optical rotary encoder and hex schmitt trigger located on the Keypad Board. This circuit generates quadrature signals (each signal being 90 degrees out of phase). The rotary encoder produces 120 pulses per revolution of the Main Tuning Knob. The four quadrature signals are sent via connector 93 to U2 and U3. These gates detect the leading and trailing edges of the signals and generate an output pulse for each edge, thus multiplying the number of pulses by four. The pulses are summed by diodes D8-D15 and applied to U4A and U4B which are connected as a flip-flop to detect the direction of the encoder. The UP/DOWN output of U4 goes to PA0 of

U8. The summed pulses are applied through D16 and D17 to U4C and U4D. The clockpulses thus generated (480 per revolution of the encoder) are applied via C13 to the IRQ line of U8. They are also sent to U5 which buffers the signal and then integrates it to develop a tuning rate detector. When the number of pulses exceeds a predetermined threshold, the output of U5D goes high. This signal is connected to PE3 of U7 and is monitored by U8. When U8 sees the SHIFT line go high, it changes the tuning step size of the synthesizer to a larger value.

Connector 80 supplies the audio signal from the RTC (beep) and the optional Voice Readout to the audio circuits of the PARAGON II.

Connector G goes to an externally mounted high current +5.6 Volt regulator mounted on the right side panel of the PARAGON II

Connector I supplies +13.5 Volts primary power for the externally mounted +5.6 Volt regulator and for U1, the 32 bit serial driver.

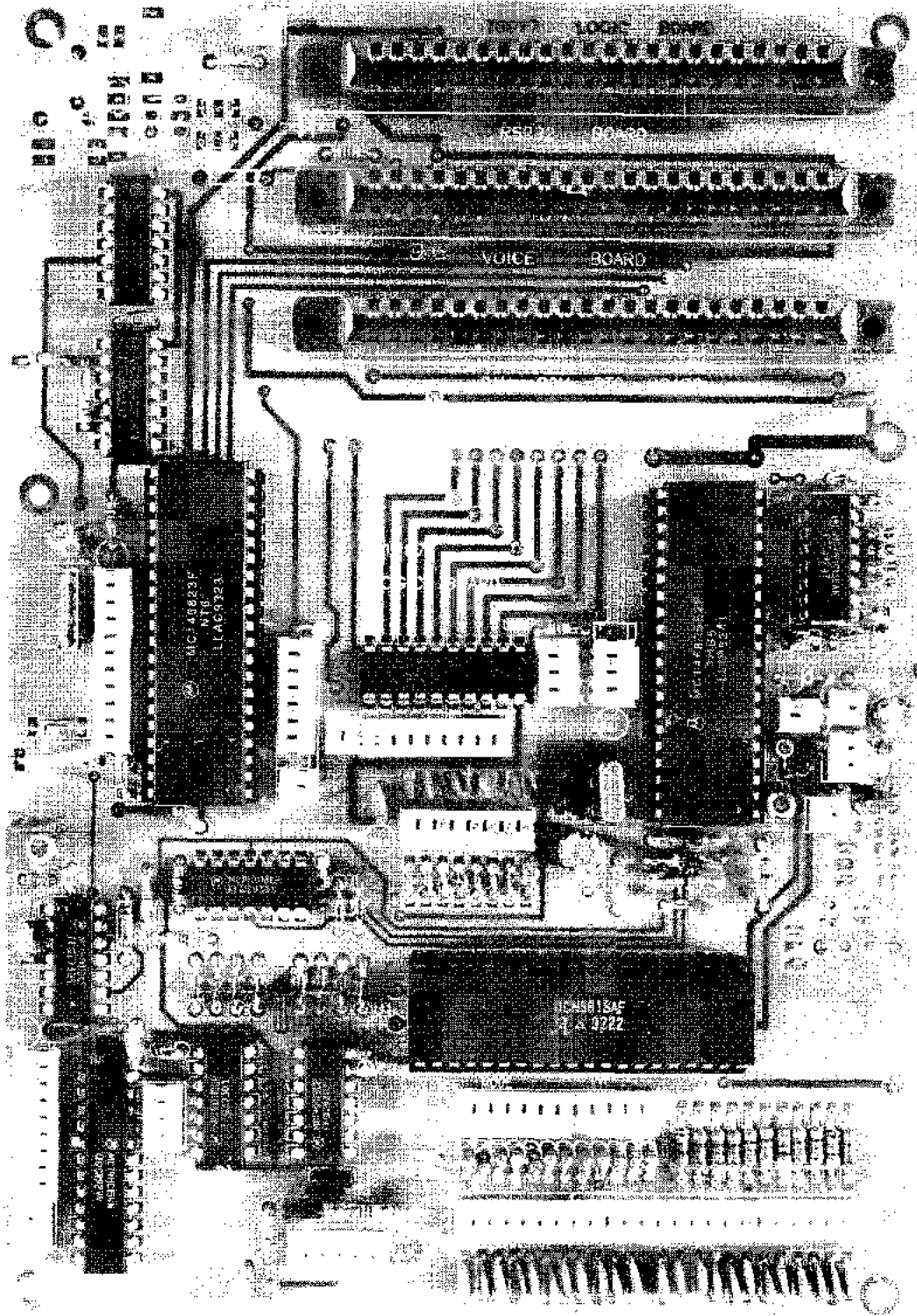
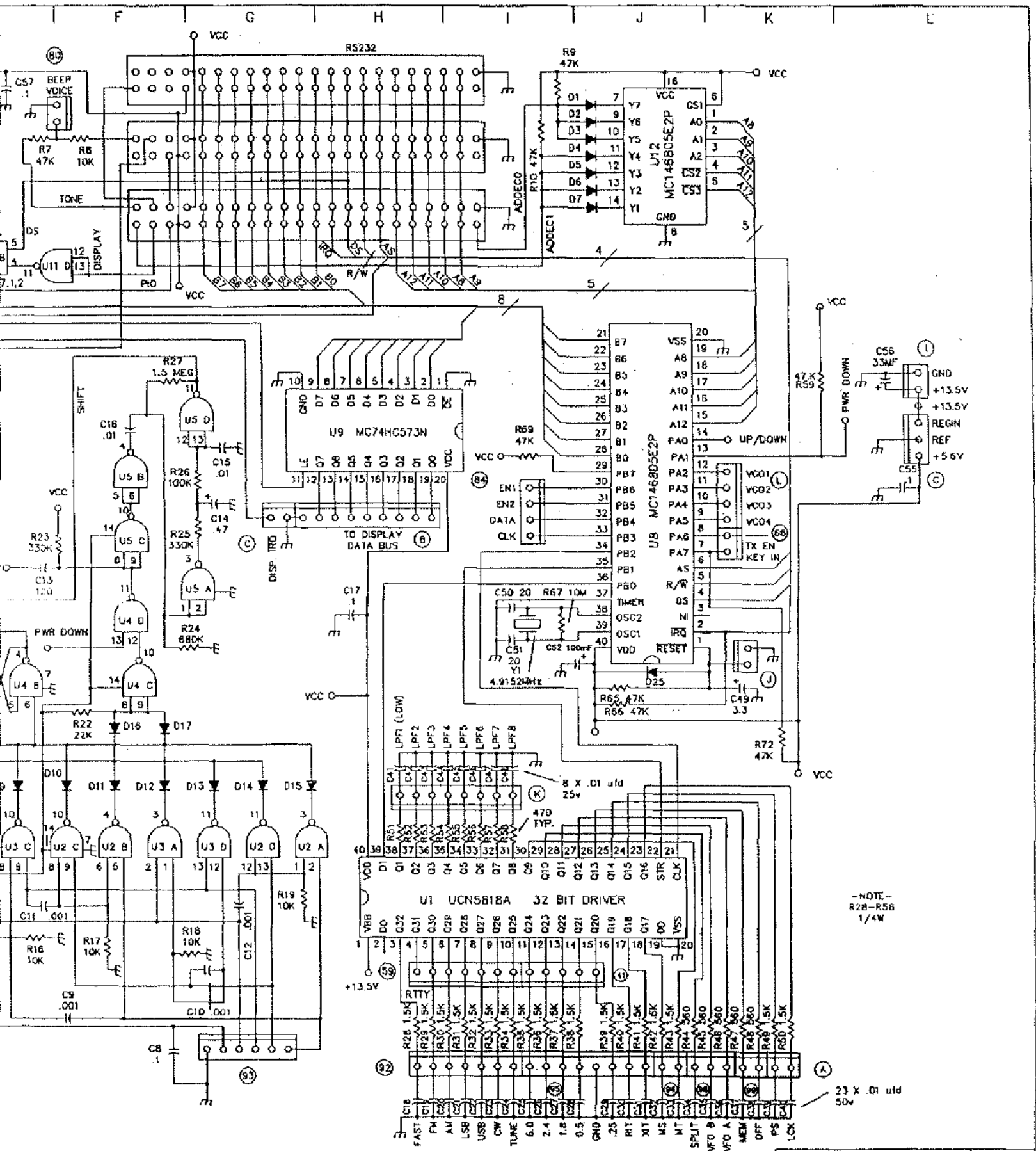

FIGURE 4-1. LOGIC BOARD COMPONENT LAYOUT (81267-1)



4-2. LOGIC BOARD SCHEMATIC (81267-1)

LOGIC BOARD | 81267-1

4-5/4-6 BLANK

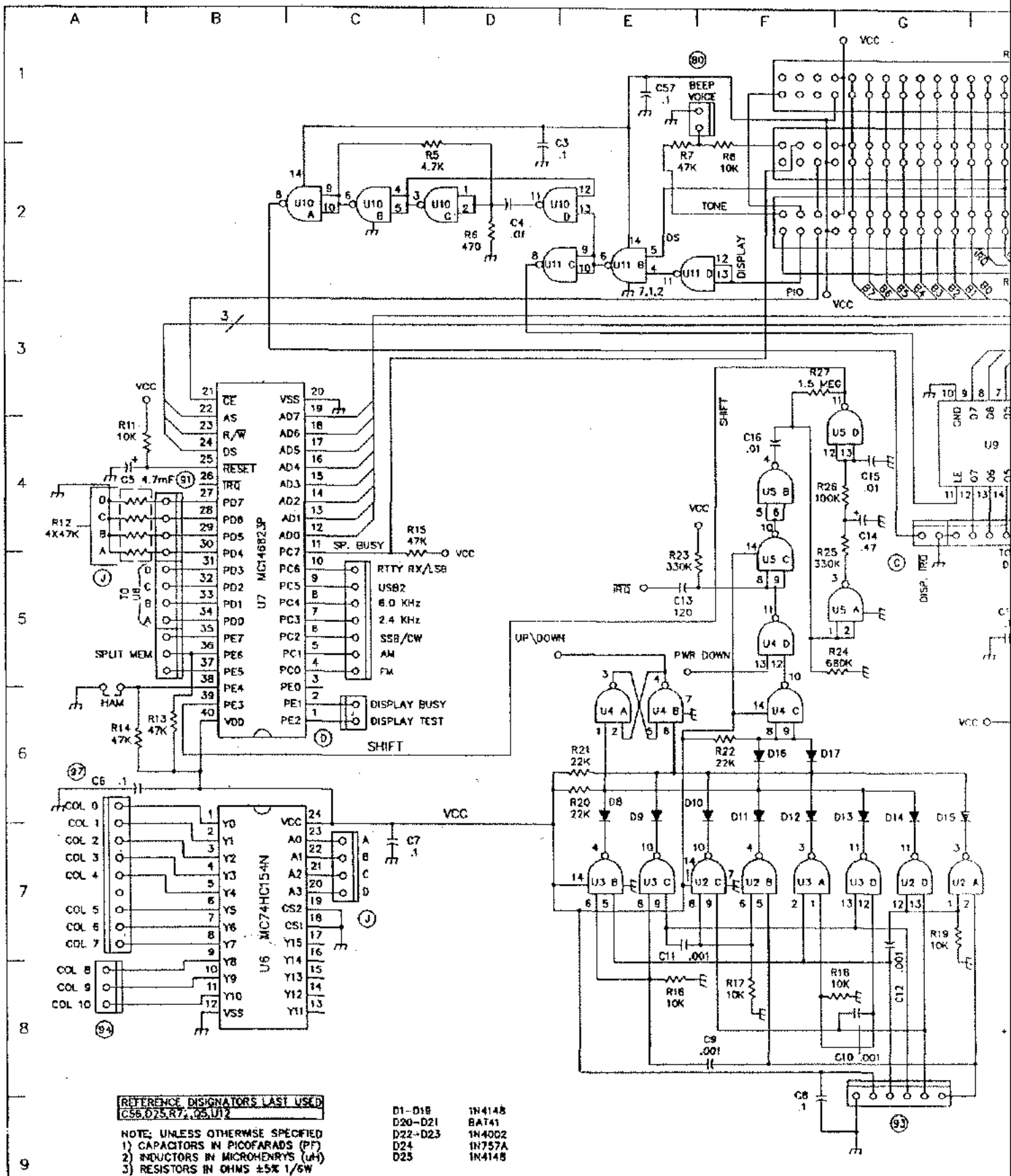

FIGURE 4-2. LOGIC BOARD SCHEMATIC (8)

4-3. VF DISPLAY BOARD (81269-1)

This board contains the twenty character alphanumeric vacuum fluorescent display, DISPI, and the segment and digit driver integrated circuits required to drive the display. Also on this board is an array of 5 LED's used to annunciate the various display modes currently in use.

The display segments (SGA-SGO, PNT) are driven by integrated circuits U1 and U2, which are latched 8-bit parallel high voltage drivers. The data for each of these devices is provided by the microprocessor on the VF Display Control Board via the 8-bit data bus (D0-D7). When the ENO line of P1 goes high, U1 is enabled. The STRB line is the pulsed high to load the data for U1 into the latches. Likewise, when EN1 goes high, U2 is enabled and when STRB is pulsed high its data is latched.

The display digits (DG1-DG10) are driven by U3, while digits (DG11-DG20) are driven by U4. These are both 10-bit, serial input, latched high voltage drivers. Data for each device is sent by the microprocessor on the VF Display Control Board via the SRIN line of P2.

This data is clocked into each device by a low to high logic transition on the CLK line of P2. These two drivers are connected in cascade such that the serial output data (SDO) of U3 is connected to the serial data input (SDI) of U4. Therefore, all twenty bits are loaded serially by the microprocessor.

Since this is a multiplexed display system (only one digit is turned on at a time), the display must be blanked while data is being loaded and latched. When the BLNK line goes high, all drivers are turned off causing the display to be blanked. For best viewing contrast and minimum ghosting, the digits are turned on for approximately 500 uS, and blanked for 100 uS. The digits are scanned from left to right (DG1 to DG 20).

Power for the display drivers is provided by the +5V pin on P2. Pin +VBB provides the high voltage (+30VDC) required to drive the vacuum fluorescent display DISPI.

Connector 98 provides signals for the LEDs used to annunciate VFO A, VFO B, and SPLIT. Connector 99 provides signals for Offset (OFF) and MEM.

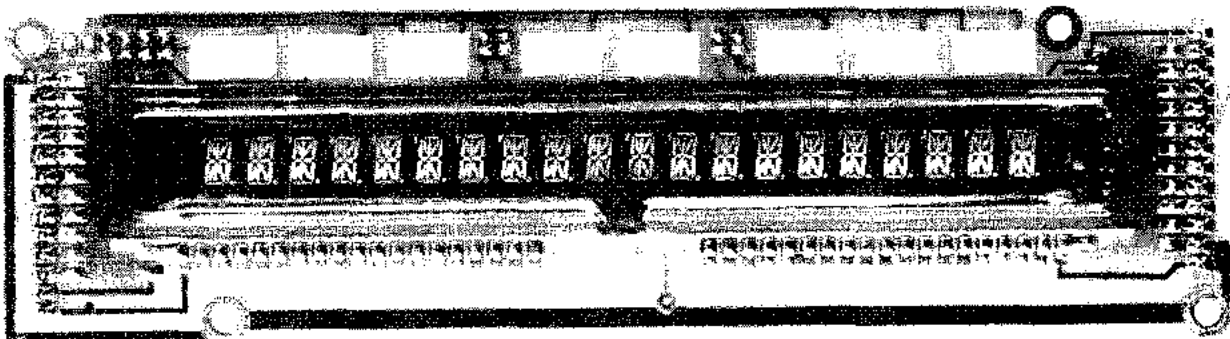
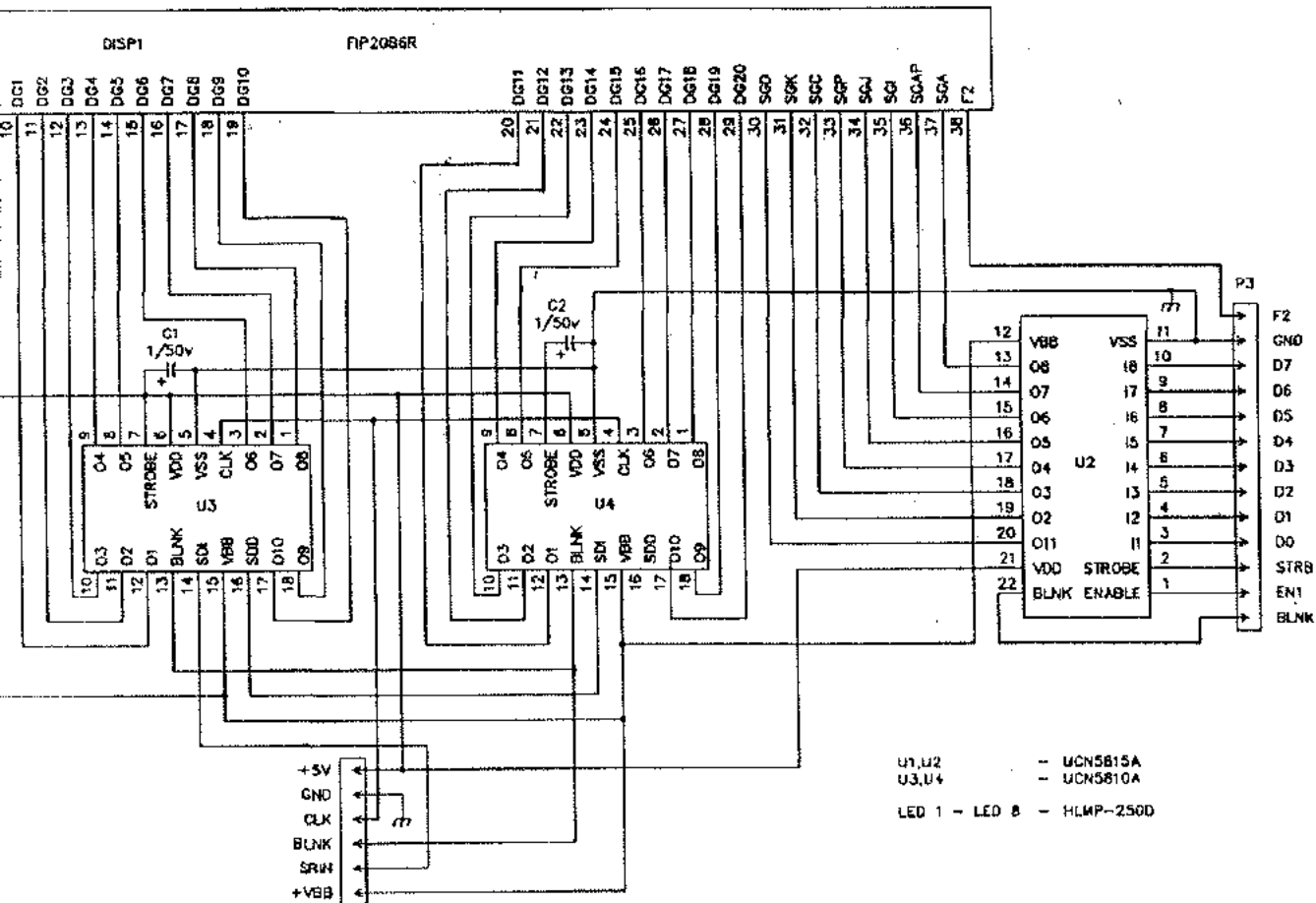

FIGURE 4-3. VF DISPLAY BOARD COMPONENT LAYOUT (81269-1)



U1,U2 - UCN5815A
 U3,U4 - UCN5810A
 LED 1 - LED 8 - HLMP-2500

FIGURE 4-4. VF DISPLAY BOARD SCHEMATIC (81269-1)

VF DISPLAY

81269-1

Part No. 74242
 October 1993
 Printed in U.S.A.

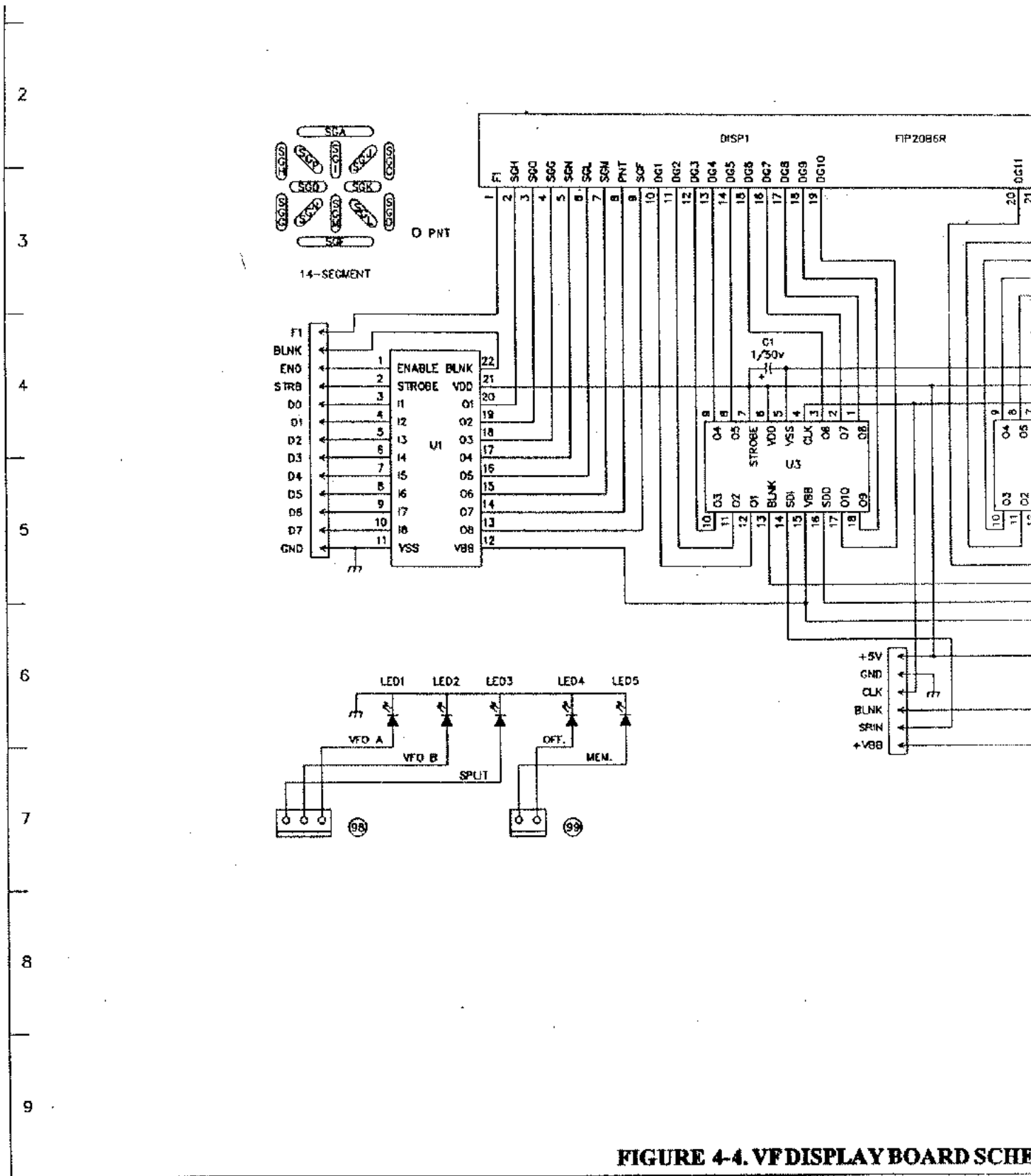

FIGURE 4-4. VF DISPLAY BOARD SCHE

4-8/4-9 BLANK

4-4. UPPER POT BOARD (81326)

This assembly contains three dual concentric controls, a latching push-button switch and a LED indicator. The board mounts on the left front subpanel at the control positions of AF GAIN and TONE, FADE and BP FILTER, PBT and NOTCH, and the ATTN switch.

The ATTN switch S1 is wired to the receive bandpass board by connector 18 where it controls the insertion of the receiver attenuator pad. When the pad is inserted, S1 applies 13.5 Volts to the anode of -20 dB indicator LED D1 which supplies a forward current through connector 18 to a dropping resistor on the receive bandpass board.

The AF GAIN control R5 forms a voltage divider at the output of fader network R1-R4 and R7 to select a controlled amount of audio signal for input to the audio amplifier on the IF/AF board via connector 55.

Unfiltered and filtered audio from the IF/AF board and connector 55 drive fader network resistors R1 and R2 respectively. The wiper of FADE control R7 is grounded through the center pin of connector 55 forming proportional voltage dividers with R1 and R2. The filtered and unfiltered portions are added to-

gether at the AF GAIN control R5 by summing resistor R3 and R4. Clockwise rotation of R7 increase the filtered portion and decreases the unfiltered portion of audio delivered to R5.

BP FILTER control R8 sets a dc voltage which determines the center frequency of the audio bandpass filter on the IF/AF board via connector 54 and increases the center frequency of the filter.

TONE control R6 is part of a "high cut" filter circuit between audio stage on the IF/AF board. Clockwise rotation of R6 reduces the amount of high frequency rolloff in the receive audio path.

NOTCH control R10, through connector 53 to the IF/AF board, varies a dc voltage to a clock oscillator which determines the frequency of the audio notch filter. Clockwise rotation of R10 increases the voltage at the center pin of connector 53, increasing the notch frequency.

The PBT control R9 connects to the pass-band tuning board through connector 42 where it controls the dc bias to the 15.3 MHz pass-band tuning VCXO. Clockwise rotation of R9 increase the voltage on the center pin of connector 42, increasing the frequency of the VCXO.

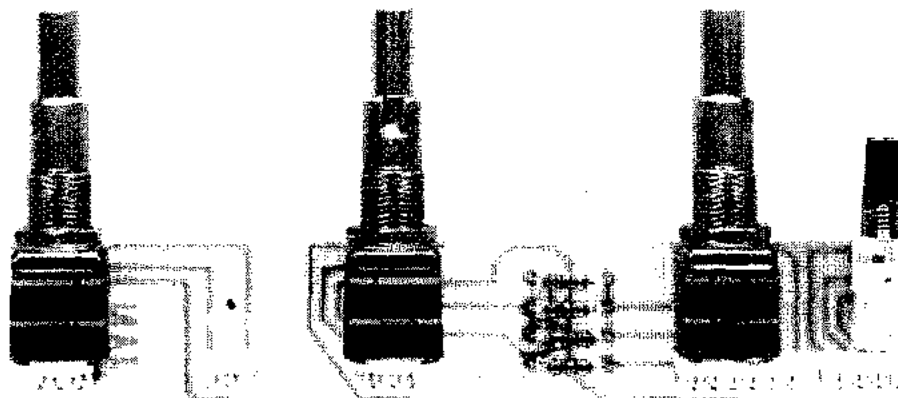
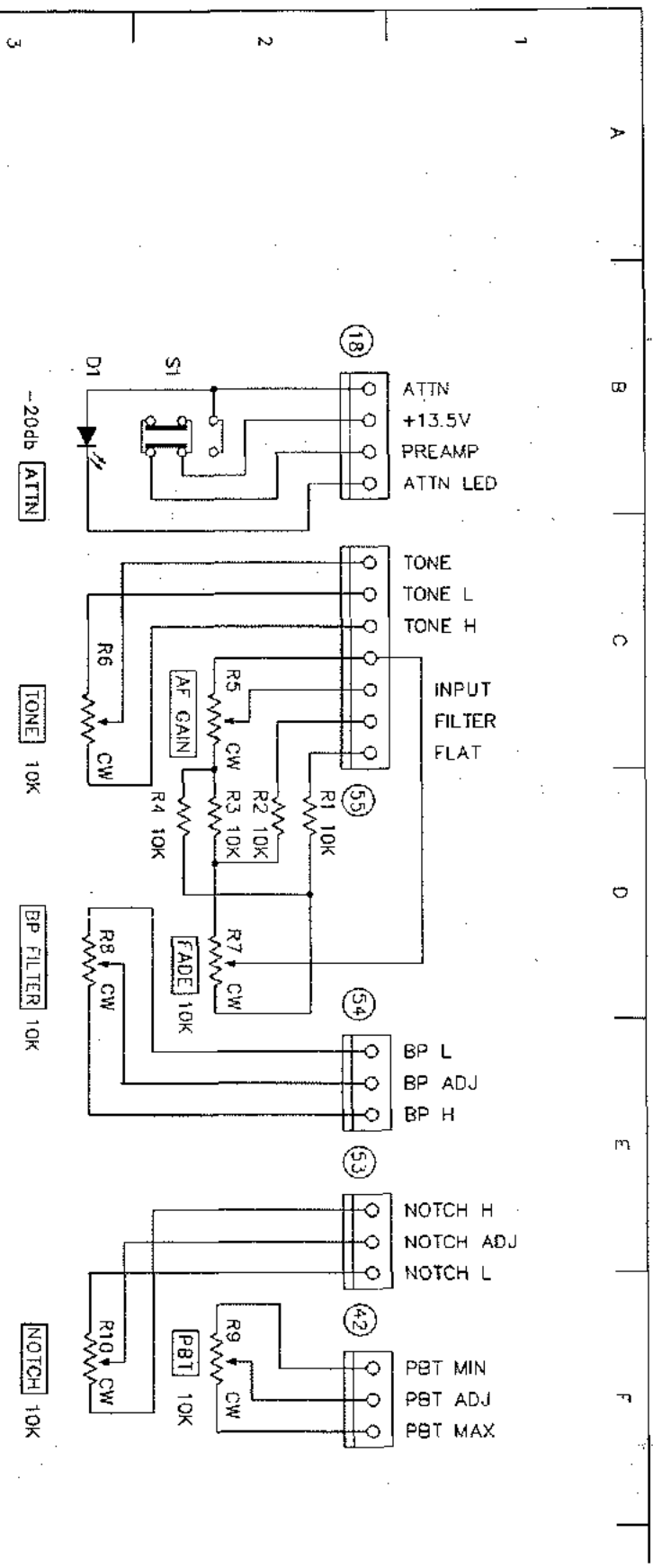

FIGURE 4-5. UPPER POT BOARD COMPONENT LAYOUT (81326)



REFERENCE DESIGNATORS LAST USED
 D1, R10, S1

NOTE: UNLESS OTHERWISE SPECIFIED
 1) CAPACITORS IN PICOFARADS (PF)
 2) INDUCTORS IN MICROHENRYS (UH)
 3) RESISTORS IN OHMS ±5% 1/4W

D1 HLMP-1840

UPPER POT BOARD

FIGURE 4-6. UPPER POT BOARD SCHEMATIC (81326)

4-5. SWITCH BOARD (81327)

The switch board contains five latching push-button switches which control the functions of Noise Blanker, VOX/PTT, QSK slow/fast, AGC on/off, and AGC fast/slow. This assembly is mounted on the left front subpanel just to the right of the main power switch.

Through connector 68, NB switch S1 feeds regulated voltage to the noise blanker pulse amplifier on the low level amplifier board enabling the noise blanker function.

VOX/PTT switch S2 selects the keying source to be sent to the control board via connector 65. Connector 69 carries the push to talk line and microphone polarizing voltage from the front panel MIC connector. The polarizing voltage loops directly to the control

board connector 65, and the PTT line is switched to the control board when S2 is in the PTT position. When S2 is in the VOX position, the VOX output from the TX audio/BFO board at connector 68 is switched to connector 65 and the control board keying circuit.

In the slow position, QSK fast/slow switch S3 increases the recovery time of the mute circuit on the IF/AF board by connecting in additional capacitance via connector 48.

AGC off/on switch S4 disables the AGC circuit on the IF/AF board by grounding the AGC amplifier input through connector 49.

AGC fast/slow switch S5 increases the AGC decay time in the slow position by grounding the bottom end of an additional integrating capacitor in the AGC circuit.



FIGURE 4-7. SWITCH BOARD COMPONENT LAYOUT (81327)

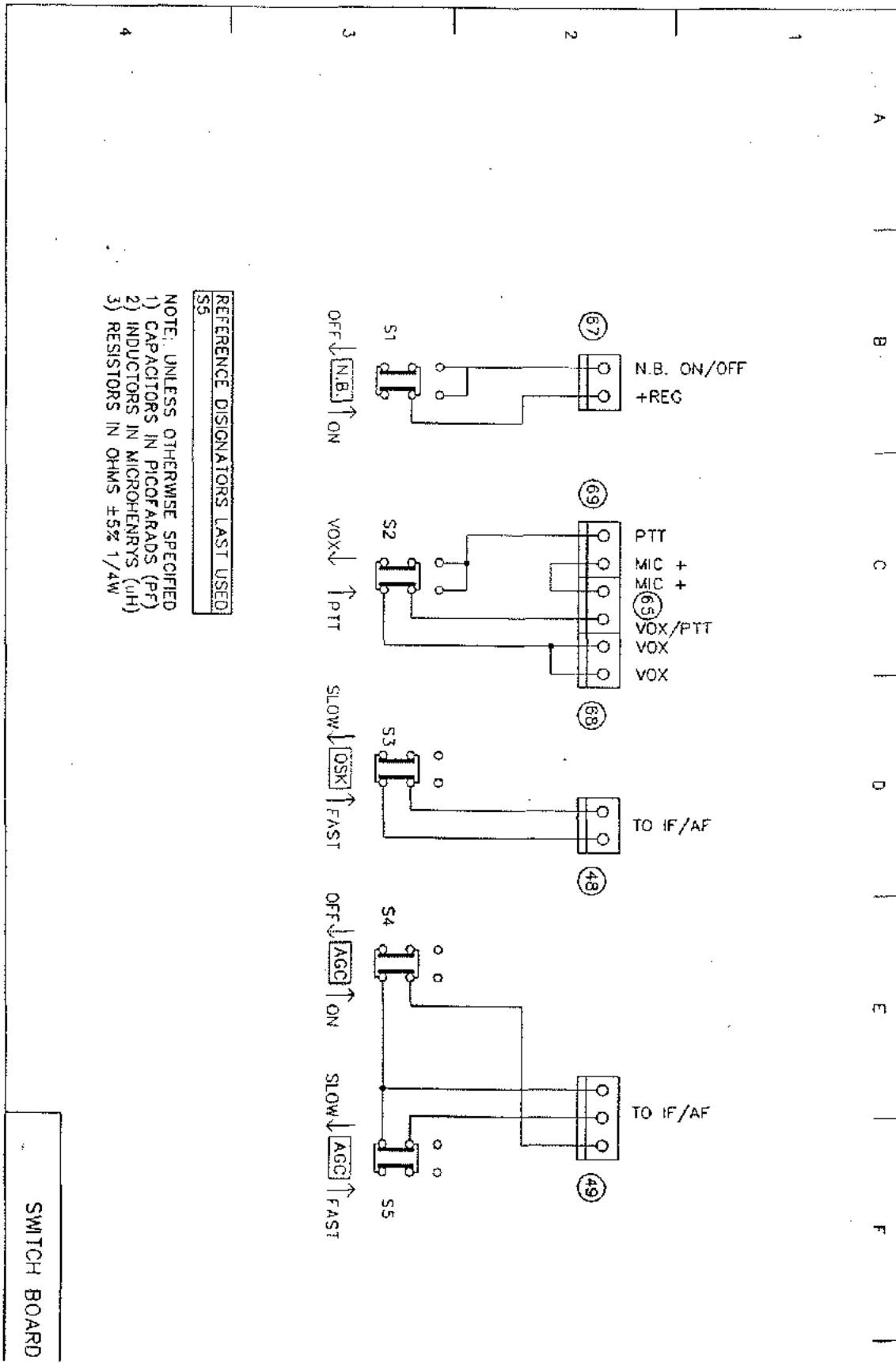

FIGURE 4-8. SWITCH BOARD SCHEMATIC (81327)

4-6. VF DISPLAY CONTROL BOARD (81359)

This board contains a microprocessor, U1, which is used to control all operations of the vacuum fluorescent display system. Also on this board is a DC-to-DC converter used to generate the +30 volts required to drive the display. There is also a low current +5 volt regulator, U3, which provides power for U1 and the digit drivers on the VF Display Board.

Microprocessor U1 receives information from the main microprocessor, located on the Logic Board, via the 8-bit data bus DD0-DD7. When the main microprocessor wishes to update the display, it latches the data on the DD0-DD7 bus and then pulses the IRQ line (on connector C) low. This tells U1 that it has data on the bus to be processed. At this time, U1 sets the BUSY line (on connector D) high to tell the main microprocessor that it is busy processing the data. After it has finished processing the data byte, U1 sets the BUSY line low again and the main microprocessor continues sending the next byte of information. This back and forth exchange continues until U1 has received information for all twenty digits in the display.

When it is not processing data from the main microprocessor, U1 is generating the required scanning signals for the drivers on the VF Display Board. The speed at which U1 operates is controlled by crystal Y1 (4.096 MHz). This clock signal is internally divided by four to yield an internal bus frequency of approximately 1.024 MHz and an execution cycle time of about .977 μ S.

The DC-to-DC converter consists of U2, a free running oscillator, and a voltage tripler circuit consisting of diodes D2-D6 and capacitors C9-C14. In addition, D1, a 9.1 volt zener diode, helps provide some degree of voltage regulation. The frequency of oscillation of U2 is controlled by C1 and the combination of R1 and R2. The ratio of R1 and R2 is selected so that the output signal appearing at pin 3 of U2 is a square wave of 50% duty cycle. There are two output voltage levels available from the DC-to-DC converter. The normal output is about +30VDC, but a lower value of about +20VDC is also available for providing a dimmer display if desired. These are selected by the jumper plug connected to the mass term connector with +VEE on it.

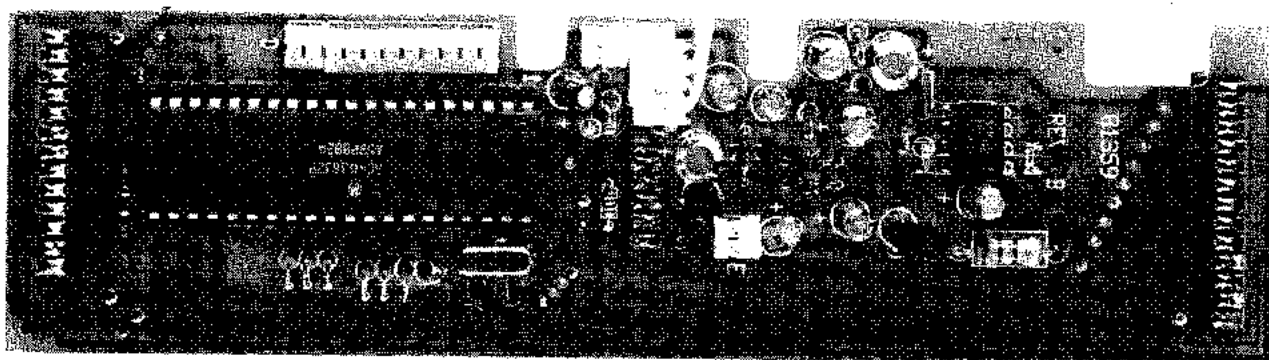
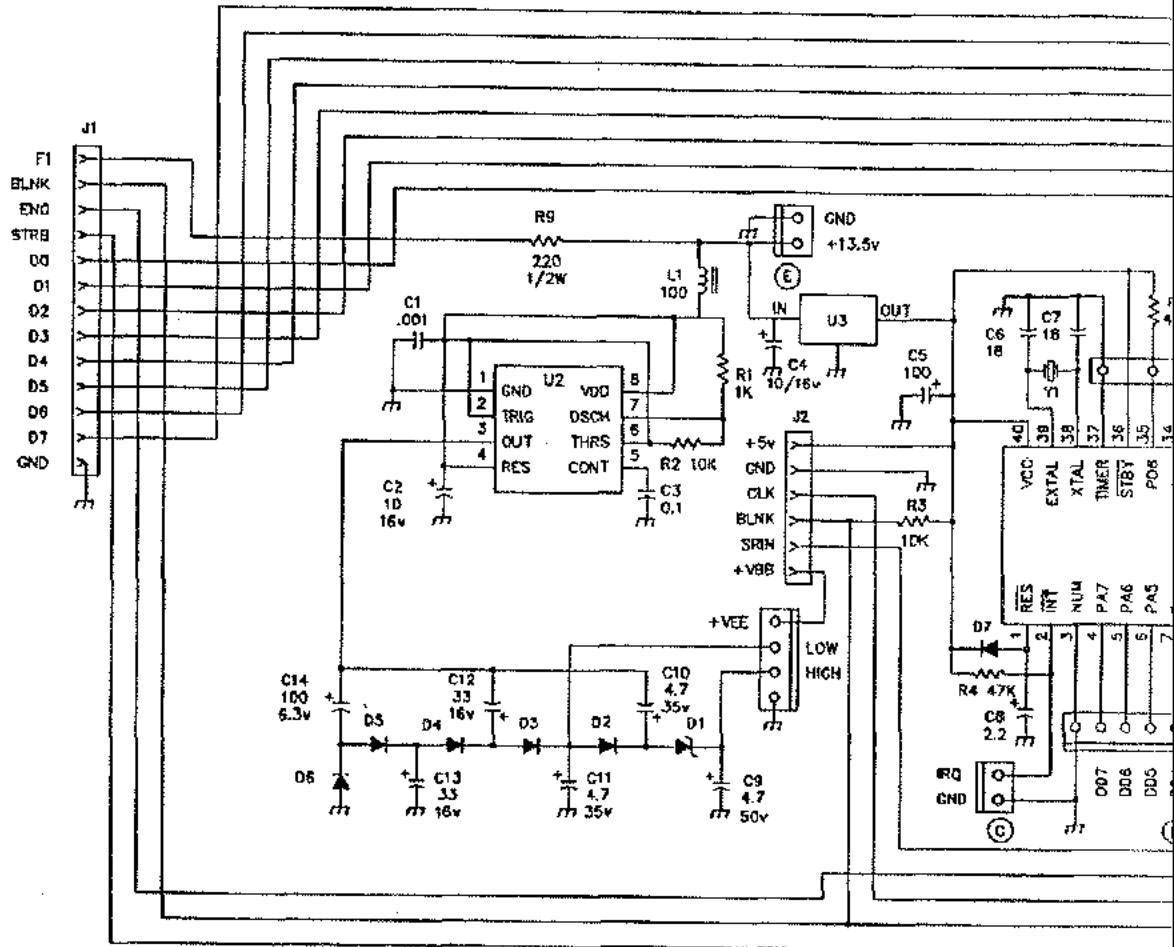

FIGURE 4-9. VF DISPLAY CONTROL BOARD COMPONENT LAYOUT (81359)

2
3
4
5
6
7
8
9



REFERENCE DESIGNATORS LAST USED
 C14, D7, A1, R9, U3

NOTE: UNLESS OTHERWISE SPECIFIED
 1) CAPACITORS IN PICO FARADS (PF)
 2) INDUCTORS IN MICROHENRYS (μ H)
 3) RESISTORS IN OHMS $\pm 5\%$ 1/4W

U1 - HD037A05V0P
 U2 - NE555N
 U3 - LM2931Z5P
 D1 - 1N751,9.1 Volts
 D2-D7 - 1N4148
 Y1 - 4.088 MHz

FIGURE 4-10. VF DISPLAY CONTROL BOARD SCHEM

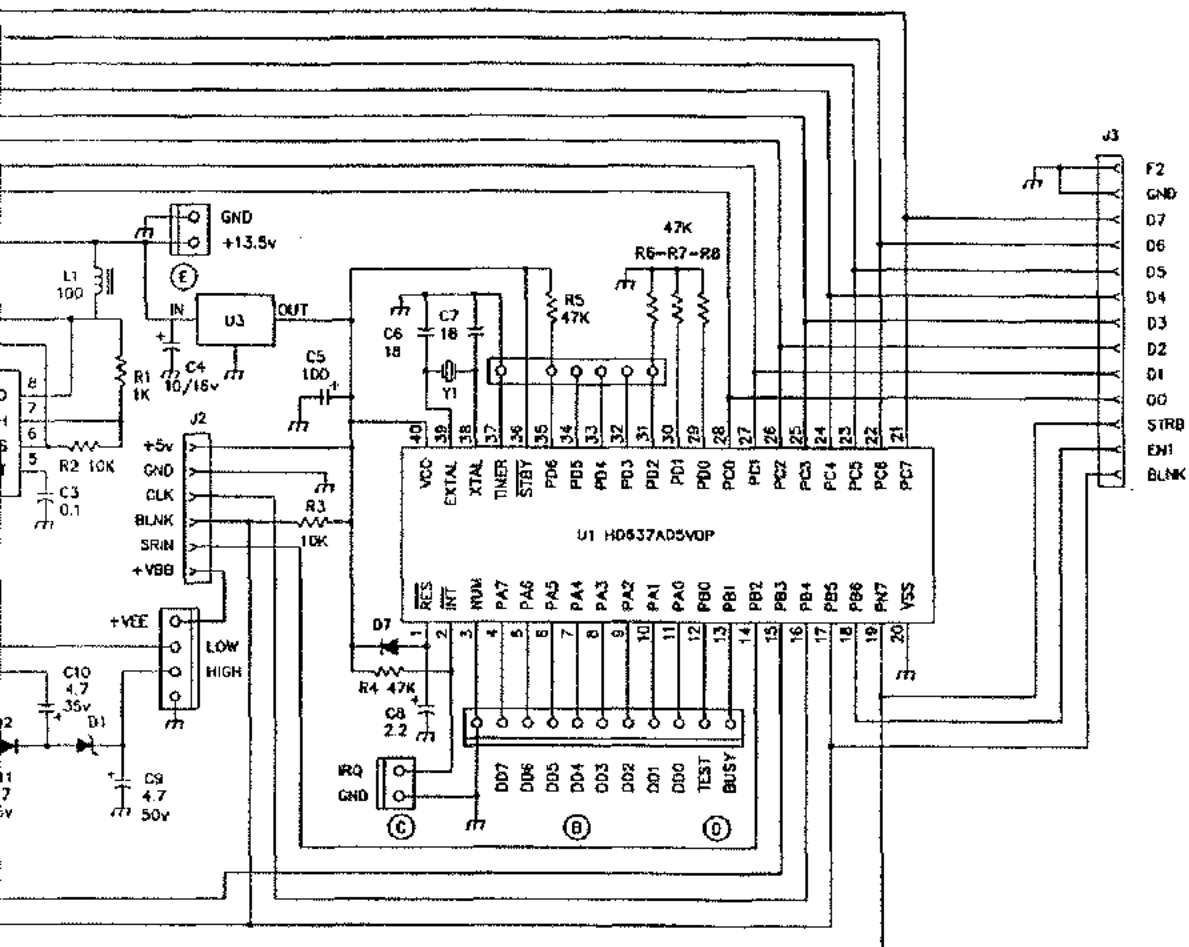

- U1 - HD637A05VOP
- U2 - NE555N
- U3 - LM2931Z5P
- D1 - 1N4751, 3.1 Volts
- D2-D7 - 1N4148
- Y1 - 4.096 Mhz

DISPLAY CONTROL BOARD SCHEMATIC (81359)

DISPLAY CONTROL	81359
Part No. 74242	
October 1993	
Printed in U.S.A.	

4-7. RAM-ROM-RTC BOARD (81360-1)

This board contains a Real Time Clock, CMOS RAM and EPROM, and address decoding circuits. The Real Time Clock, U3, keeps track of the time in a 24 hour format. U3 also has a built-in square wave generator which is used to generate the beep tone for the keypad. This signal is output on the SQW pin of U3 and sent to transistor Q1 which amplifies the signal to a useful level. The output of Q1 is fed to a lowpass filter consisting of R7, R8, C6, and C7, to filter this waveform. This signal is then fed to the edge card connector and eventually to connector 80 on the logic board.

U7 and U8 form an address decoder which provides several enable signals to the various memory mapped devices tied to the multiplexed address/data bus system. The output from Y0 of U8 is enabled for memory addresses 80H-8FH, which is reserved for U3, the Real Time Clock. Output Y1 of U8 is enabled for addresses 90H-93H, which is reserved for the RS232 Interface. Output Y2 of U8 is enabled for address A0H, which is the VF Display Controller. Output Y3 is enabled for address B0H, which is for the Model 257 Voice Readout Option. Output Y4 of U8 is enabled for addresses C2H-C8H, which is reserved for the I/O expander, U7 on the Logic Board. When any of the above outputs are enabled, the line goes low, at all other times it remains high.

U5 is another address decoder which is used to enable U2, a 16k nonvolatile CMOSRAM, for addresses 100H through 4FFH. When enabled, the CE pin of U2 is set low. This device contains the memory and VFO information saved by the operator. Because of memory map limitations, only the first 1024 bytes of U2 are available for storing memory information.

The BFO output from Q7 splits three ways. One output drives ALC transistor Q8 which controls the bias of oscillator transistor Q6 to maintain a constant output level. Another output serves as the carrier input to the balanced modulator U5. The third BFO output drives the product detector on the IF/AF board through connector 46.

U6 and diode D2 form another address decoder designed to enable U1 for addresses 500H through 1FFFH. When enabled, the E pin of U1 is set low. U1 is an 8K x 8 CMOS, U.V. erasable EPROM, which contains the operating instructions for the main microprocessor system. Because of memory map restrictions, only the top 6,912 bytes of U1 are available for use by the main microprocessor.

U4 is an 8 bit latch which is used to latch the lower 8 bits of the address (A0-A7) from the multiplexed address/data bus coming from the main microprocessor on the Logic Board. This latch is enabled on the rising edge of the Address Strobe (AS).

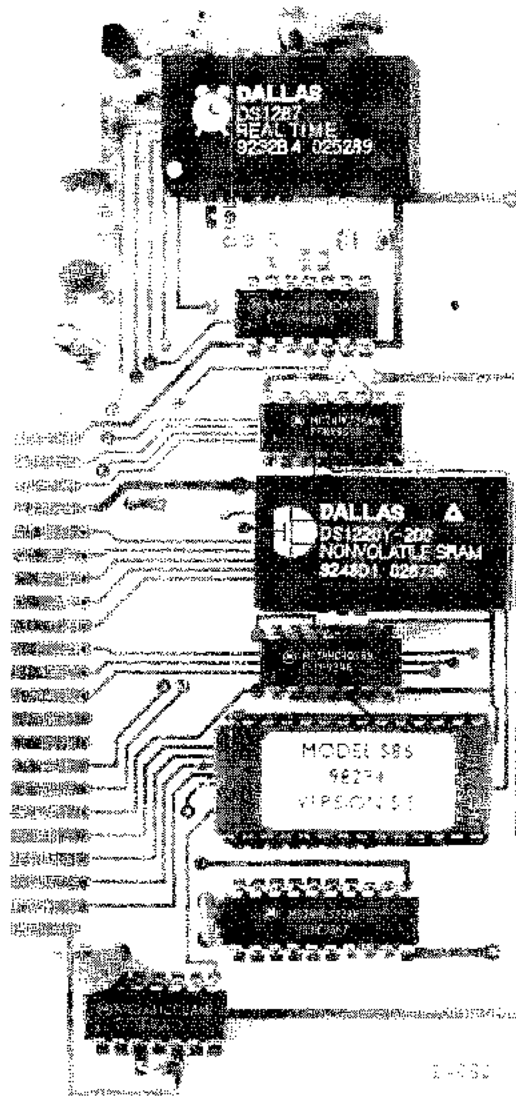
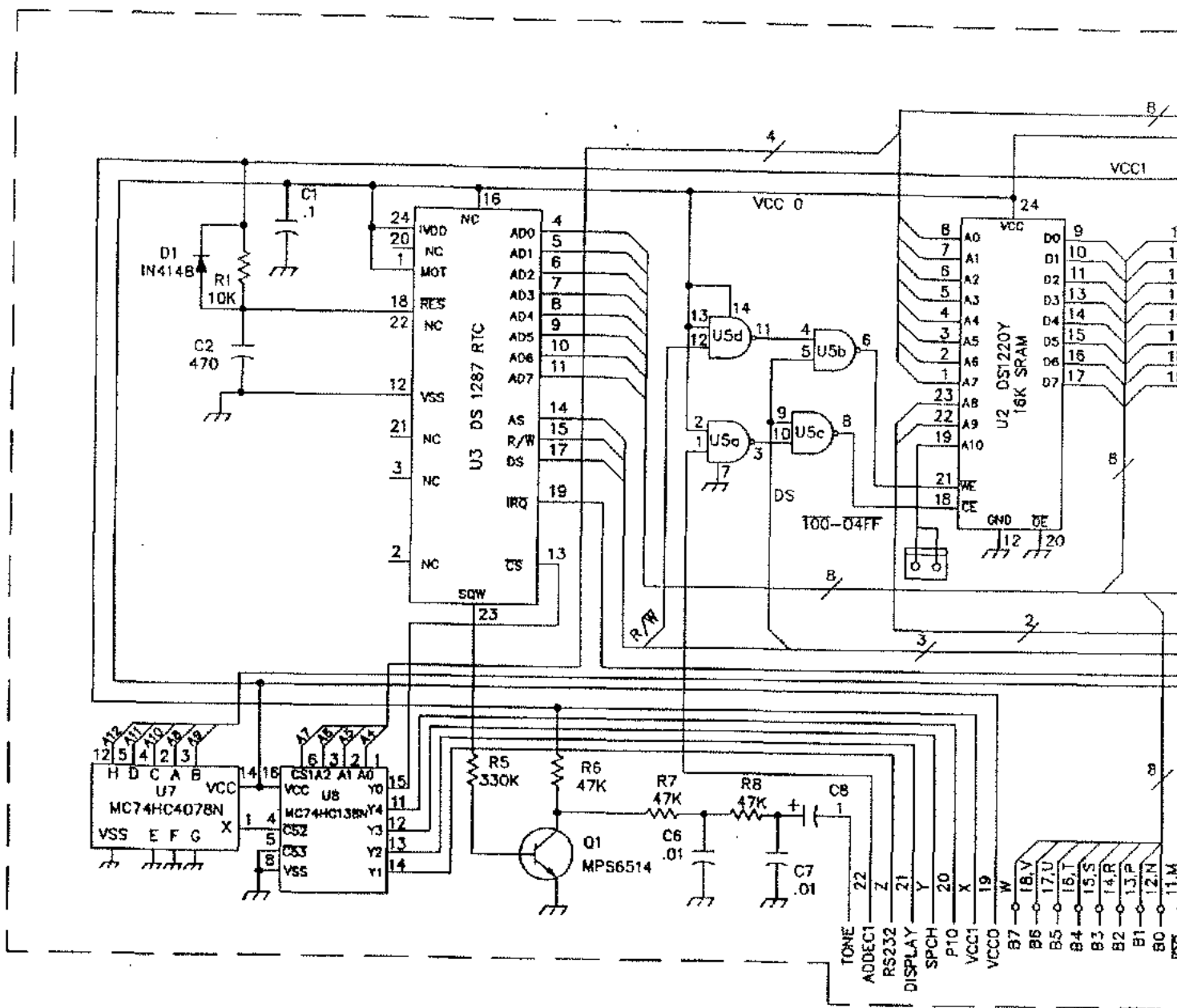
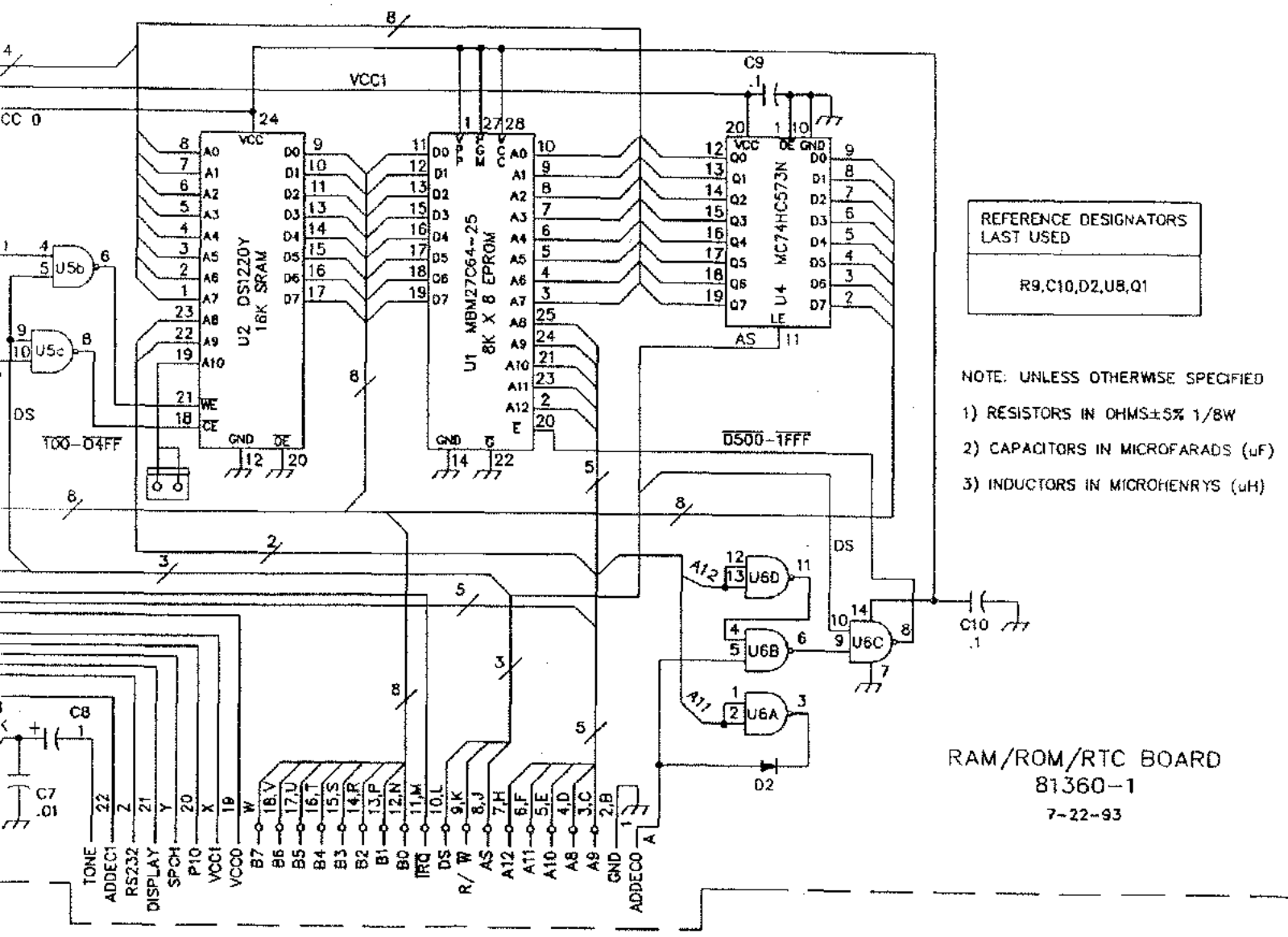

FIGURE 4-11. RAM/ROM/RTC BOARD COMPONENT LAYOUT (81360-1)



Part No. 74242
 October 1993
 Printed in U.S.A.

FIGURE 4-12. RAM/ROM/RTC BOARD SCHE



REFERENCE DESIGNATORS
LAST USED

R9,C10,D2,U8,Q1

NOTE: UNLESS OTHERWISE SPECIFIED

- 1) RESISTORS IN OHMS ±5% 1/8W
- 2) CAPACITORS IN MICROFARADS (μF)
- 3) INDUCTORS IN MICROHENRYS (μH)

RAM/ROM/RTC BOARD
81360-1
7-22-93

4-12. RAM/ROM/RTC BOARD SCHEMATIC (81360-1)

4-8. CONTROL FILTER BOARD (81377)

The control filter board is mounted on the center chassis shield partition and contains 12 pi-section LC lowpass networks to filter sensitive control lines leading to the synthesizer and lowpass filter boards.

Eight band lines from the digital board enter at connector K and are filtered before exiting to the DB-25 connector board via connector 8. Four VCO select lines from the digital board enter at connector L, are filtered, and exit to the synthesizer major loop board via connector 90.

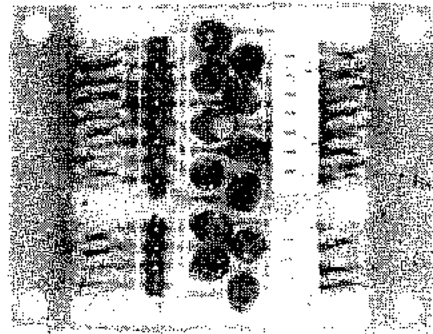
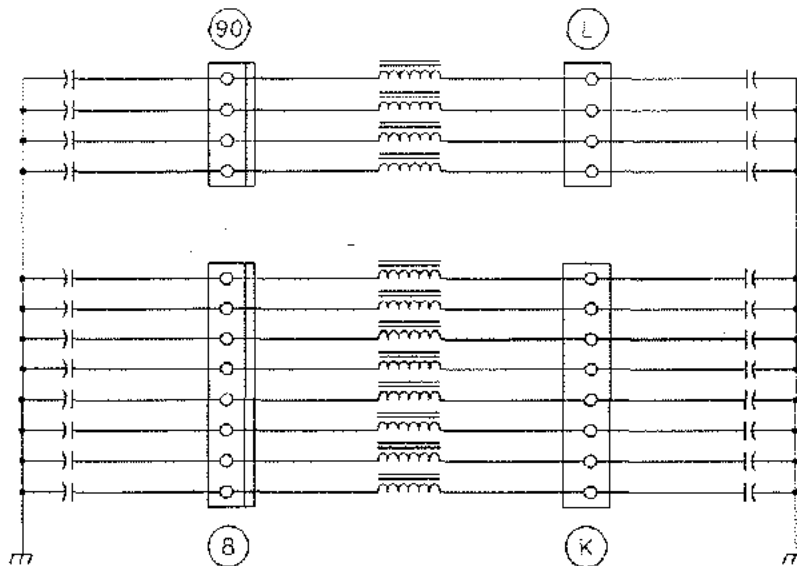

FIGURE 4-13. CONTROL FILTER BOARD COMPONENT LAYOUT (81377)



ALL CAPS ARE .01
ALL COILS ARE 100uh

FIGURE 4-14. CONTROL FILTER BOARD SCHEMATIC (81377)

60 meters in a FLASH!



**MADE
IN USA**

800-833-7373
www.tentec.com

If the 5.25-5.40 MHz band is released by the FCC for amateur radio use, as proposed, will you be ready to operate? JUPITER will be! How? JUPITER's Flash-ROM capability allows your JUPITER to be instantly upgraded by downloading a file from the Internet. Download the file, connect the radio to your computer with a serial port cable, and upgrade. Elapsed time, less than 30 seconds. How much does this cost? FREE. Great audio, instant upgrades, competitive pricing, legendary service. Is it any wonder more and more hams are buying Ten-Tec? Call or email us today for a complete information package.

\$1189



**Model 307C
External Speaker**
\$98.00



**302J Remote
Encoder/Keypad**
\$139.00



**705 Desk
Microphone**
\$99.95



**963 Switching
Power Supply**
\$169.00

TEN-TEC

1185 Dolly Parton Parkway
Sevierville, TN 37862
Sales Dept: 800-833-7373
Sales Dept: sales@tentec.com
Monday - Friday 9:00 - 5:30 EST
We accept VISA, Mastercard,
Discover, and American Express

Office: (865) 453-7172 • FAX: (865) 428-4483
Repair Dept.: (865) 428-0364 (8-4 EST)

S&H cost for Jupiter in 48 states is \$16. With Power Supply, \$21.

Model 701, Accessory Hand Mic, not shown (\$28)
538AT, Internal Auto Antenna Tuner, not shown (\$299)

4-9. RX BANDPASS FILTER (81574)

This assembly contains the band selected bandpass filters which determine the front end bandwidth of the receiver. The receive signal enters the board via connector 15. The next stage is the selectable -20dB attenuator. If the -20dB attenuator switch on the front panel is engaged, the RX signal is attenuated by -20dB. Next, the signal passes through a 30 MHz low pass filter. At this point, if AM broadcast is the desired band, the signal goes through a 1.7 MHz low pass filter and on to the front end board via connector 17 for further processing. If AM broadcasting is not the desired band, the signal goes through a 1.7 MHz high pass filter and then through one of seven bandpass filters to get the desired front end bandwidth for selected band.

PIN diodes D1-D17 select a band pass filter based on band information from connector 14. One of the eight lines from connector 14 is driven high (approximately 12 volts) by a relay driver on the transmit low pass filter board, providing forward current to the input and output PIN diodes for the selected band. The diode forward currents return through resistors R5 and R19 providing a reserve bias voltage for the diodes for the deselected bands. Connector 16 supplies 0.1-1.6 MHz band information to the 1st mixer board to disable the RF amplifier on that band.

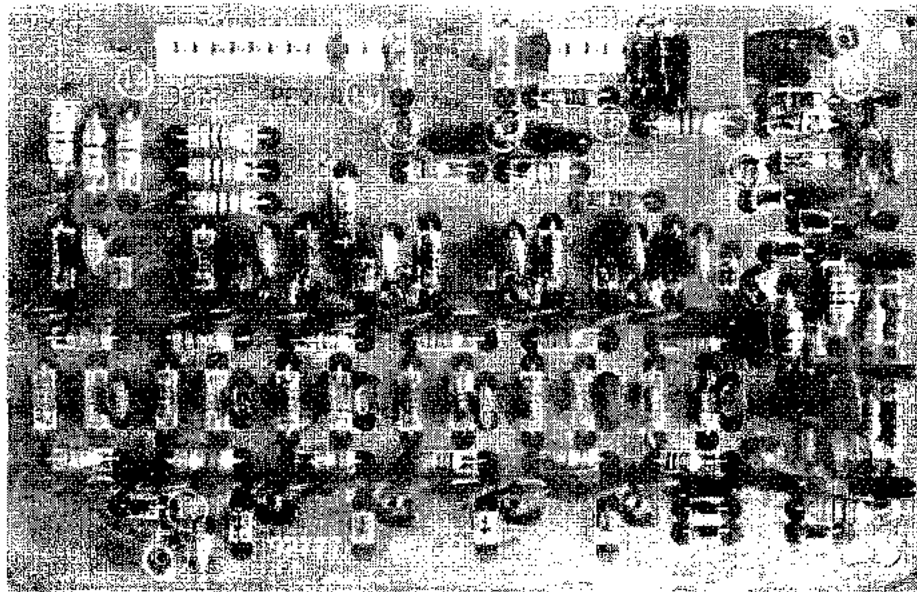
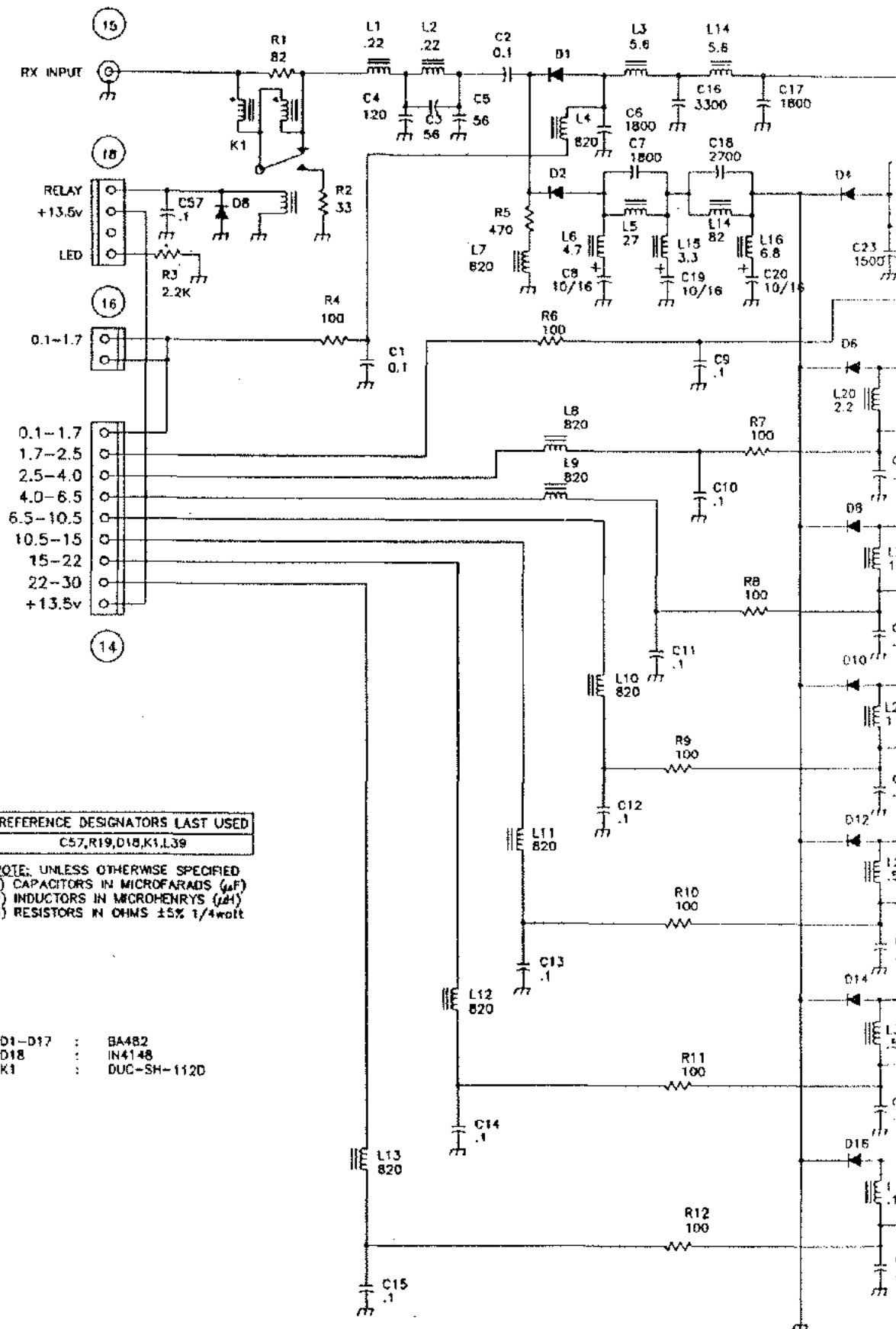

FIGURE 4-15. RX BANDPASS FILTER COMPONENT LAYOUT (81574)



REFERENCE DESIGNATORS LAST USED
C57,R19,D18,K1,L39

NOTE: UNLESS OTHERWISE SPECIFIED
1) CAPACITORS IN MICROFARADS (μF)
2) INDUCTORS IN MICROHENRYS (μH)
3) RESISTORS IN OHMS ±5% 1/4watt

D1-D17 : BA482
D18 : IN4148
K1 : DUC-SH-112D

FIGURE 4-16. RX BANDPASS SCHEMATIC

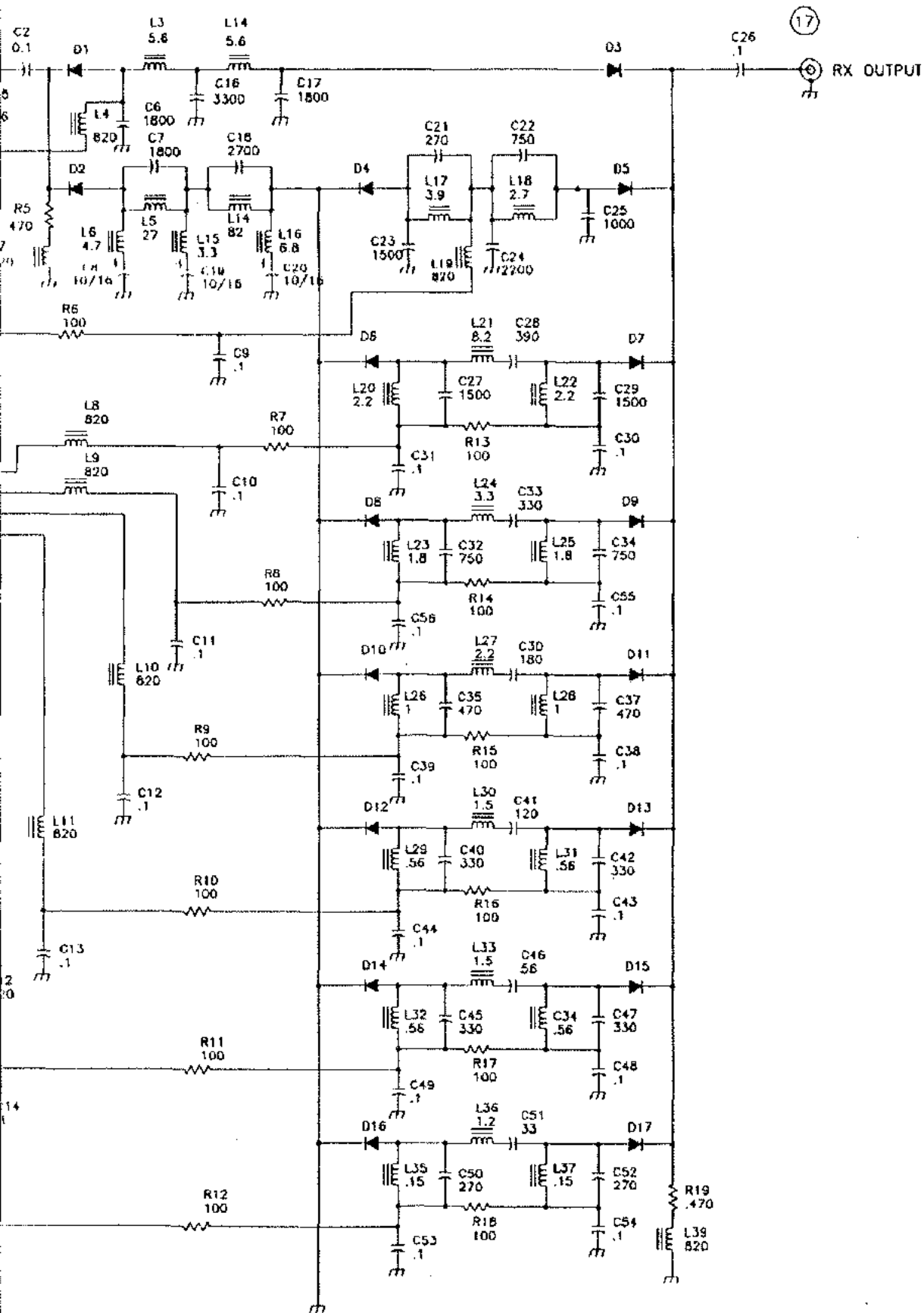

FIGURE 4-16. RX BANDPASS SCHEMATIC (81574)

4-10. POWER AMPLIFIER (81611)

The high power RF amplifier, its push-pull driver stage, and the PA bias circuits are housed in a metal box that is attached with four hex head screws to the heatsink on the back of the transceiver. The drive signal for the PA passes through connector 79 from the Low Level Driver board, and the 100 Watt output passes through a miniature coaxial cable soldered to pins on the Low Pass Filter board. "T" voltage enters the unit on the small blue wire from connector 11 on the Low Pass Filter board, and +13.5 Volts dc enters on the large red wire from the DC Input board.

Q1 and Q2 form a wideband class AB linear driver stage with input and output impedance matching accomplished by broadband transformers T1 and T3. RC networks R1-C1 and R5-C2, in conjunction with feedback networks R3-L3-C4, R6-L4-C5, control the input impedance and flatten the gain variation of the transistors over the frequency range of 1.7-30 MHz. Regulated bias is fed to this stage from Q5-U1A.

Q3 and Q4 form the high power broadband output stage of the transmitter. This stage is also biased to linear class AB operation by regulator circuit Q6-U1B. Input impedance and gain variation with frequency are controlled by RC input networks and RF feedback similar to the driver stage. Broadband transformers T4 matches the output stage to 50 ohms for driving the transmit low pass filters.

Bias for both stages is temperature compensated to maintain a relatively constant operating point by mounting the bias reference diodes D2 and D3 in thermal contact to the heatsink. The temperature dependent voltage across each reference diode is added to a portion of the "T" voltage and the sum is used as a reference voltage for the respective bias regulator U1A-Q5 or U1B-Q6 in the PS bias circuit. In receive, "T" voltage is low and both regulators are cut off, removing bias from both PA stages. When "T" goes high, capacitor C25 delays the rise of the bias reference voltages, reducing the gain of the PA until the rest of the transceiver settles into a stable transmit mode.

The bias adjustment potentiometers R19 and R15 are accessible through the bottom shield of the transceiver. To adjust PA bias, a dc amp meter must be inserted in series with the large red +13.5 Vdc lead coming from the DC Input board. Unplug connector 79 from the Low Level Driver/N.B. board to remove drive from the PA. Key the transmitter in USB mode. While watching the meter, rotate first the final bias pot R15 and then the driver bias pot R19 to produce minimum current. Now rotate the driver bias pot R19 to increase the meter reading by 50 milliamperes. Next, rotate the final bias pot R15 to produce an additional increase of 500 milliamperes on the meter. Remove the meter and reconnect the red wire to the DC Input board and connector 79 to the Low Level Driver/N.B. board.

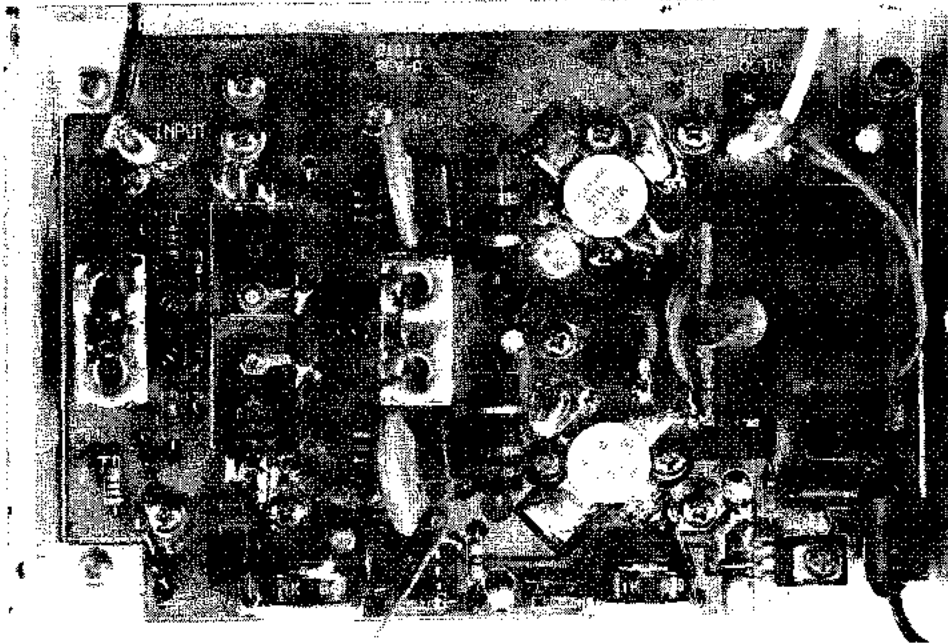
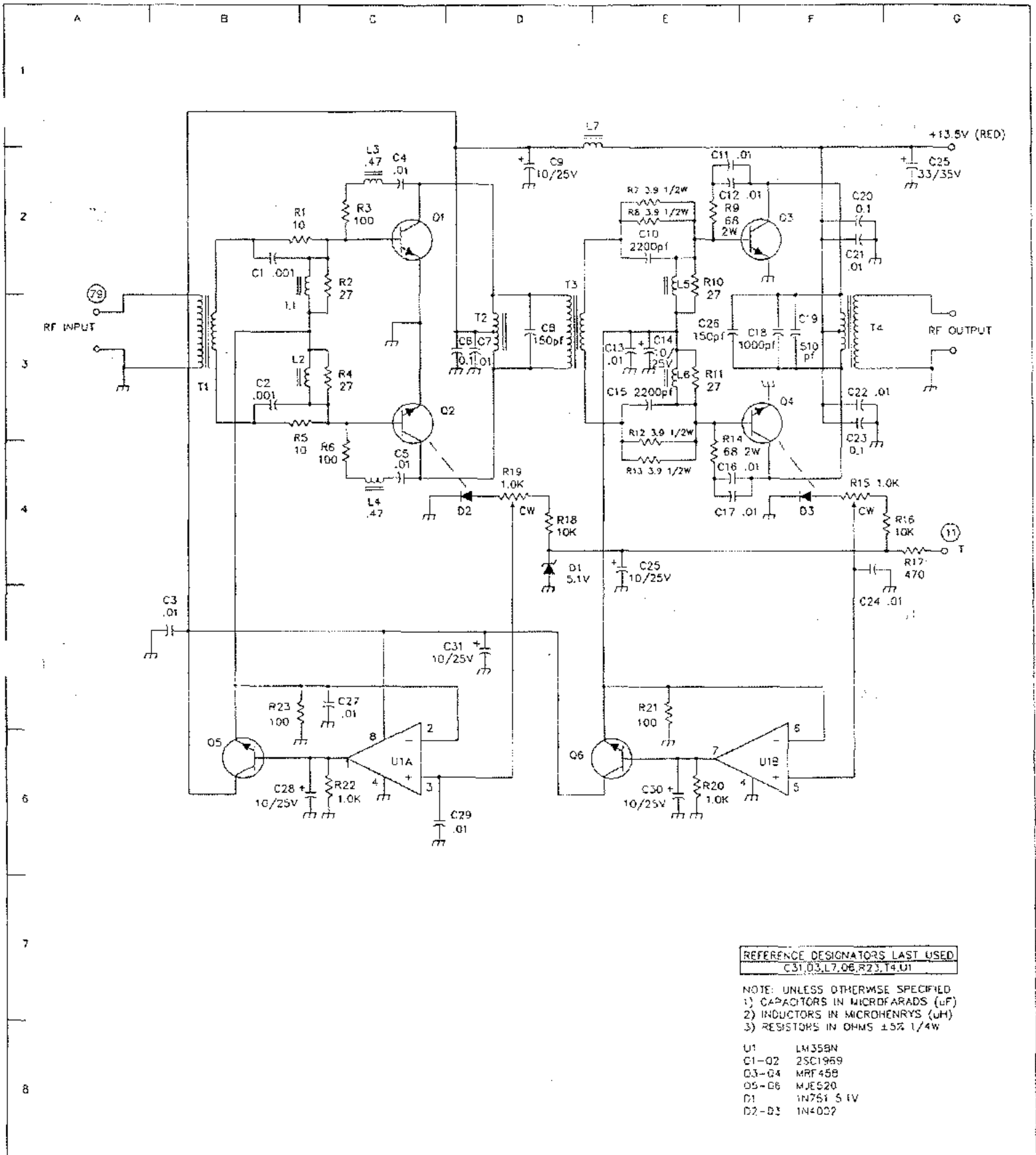

FIGURE 4-17. POWER AMPLIFIER COMPONENT LAYOUT (81611)



REFERENCE DESIGNATORS LAST USED
 C31, Q3, L7, Q6, R23, T4, U1

NOTE: UNLESS OTHERWISE SPECIFIED
 1) CAPACITORS IN MICROFARADS (μF)
 2) INDUCTORS IN MICROHENRYS (μH)
 3) RESISTORS IN OHMS ±5% 1/4W

U1 LM358N
 Q1-Q2 2SC1969
 Q3-Q4 MRF458
 Q5-Q6 MJ6520
 D1 1N751 5.1V
 D2-D3 1N4002

FIGURE 4-18. POWER AMPLIFIER SCHEMATIC (81611)

4-11. TRANSMIT LOW PASS FILTER (81621)

This board contains an array of seven 5-pole lowpass output filters, the T/R isolation circuitry, and a directional coupler for forward power and SWR detection.

Eight band lines from the DB-25 connector board enter at connector 7 where they are buffered by relay driver U1 and pass through connector 14 to energize filter select relays K1-K14. The buffered band lines also exit connector 14 to the receive band pass filter board for simultaneous selection of receive filters. Only one of the eight band lines is high at any one time depending on the operating frequency of the transceiver.

The 100 watt RF output of the PA enters the board and immediately goes through one of the seven low pass filters. The transmit signal then passes through relay K15, and continues through the primary of the SWR bridge transformer T1 to the rear panel main antenna connector.

Based on operating frequency, the proper lowpass filter is automatically selected to attenuate harmonics of the RF PA output signal to an acceptable level before radiation by the station antenna. Bridge transformer T1 and associated circuitry discriminate between forward and reflected power to develop drive voltages at connector 12 for the ALC and RF metering circuits on the 2nd mixer board.

When the transceiver is in receive, the receive signal enters connector 13 and passes through the T/R isolation circuitry on to connector 15. From here the receive signal moves on to the receive band pass board where it is filtered for the desired front end bandwidth.

Connector 9 supplies "T" and "R" voltages from the control board. "T" voltage is used to energize relay K15, and inform the PA of transmit condition via connector 11. "R" voltage is used to put T/R isolation circuitry in bypass mode.

Connector 4 supplies the necessary +13.5V to the relay driver U1.



C3

FIGURE 4-19. TRANSMIT LOW PASS FILTER COMPONENT LAYOUT (81621)

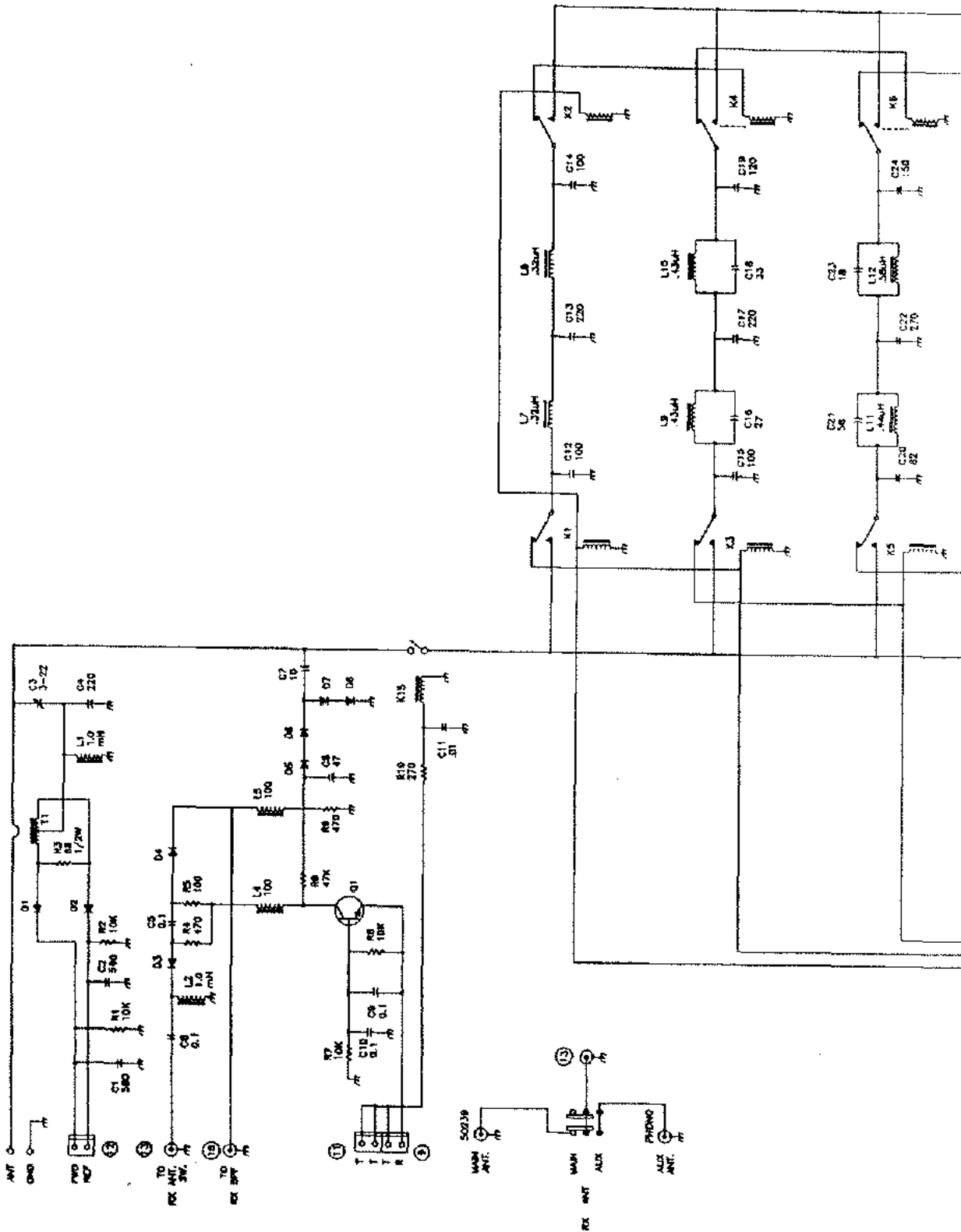
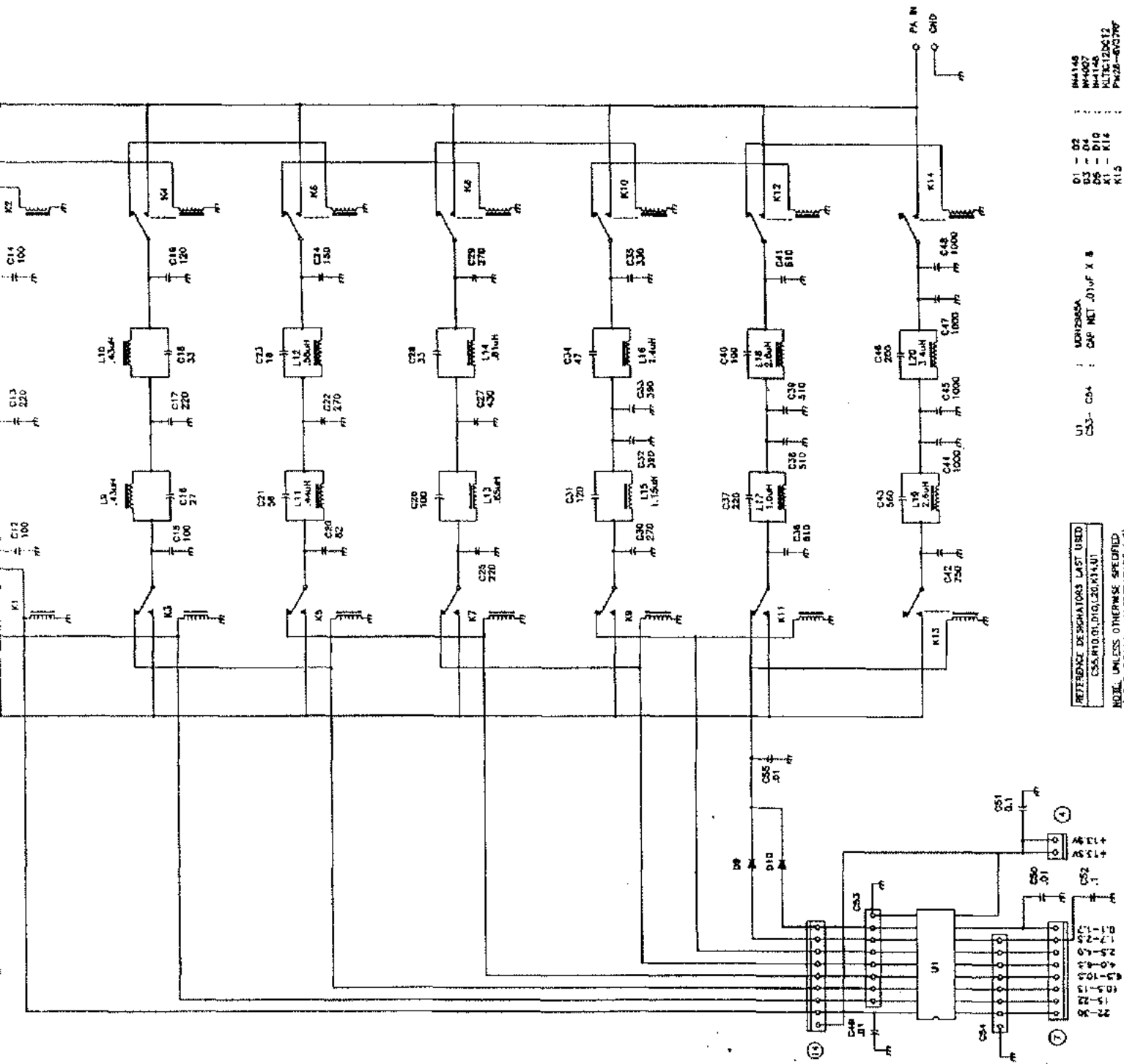

FIGURE 4-20. TRANSMIT LOWPASS FILTER SCHE



M4145
 M4007
 M4145
 ALTEC 125C12
 P422-400P4F

U1 - M4007A
 C43 - C44 : CAP NET .01 μF X 8

REFERENCE DESIGNATORS LIST USED
 C55, R10, D1, D10, L20, R14, U1

NOTE: UNLESS OTHERWISE SPECIFIED:
 1) CAPACITORS IN MICROFARADS (μF)
 2) INDUCTORS IN MICROHENRYS (μH)
 3) RESISTORS IN OHMS (Ω)

TRANSMIT LOWPASS FILTER SCHEMATIC (81621)

4-12. DC POWER INPUT BOARD (81622)

This module is located inside the low pass filter cage at the back of the transceiver. On the rear panel, the DC Power connector brings in +13.5 VDC through fuse F1. Only a fast blow style AGC25 should be used here.

On the DC Power Input board, Q2 controls the power-on relay K1. Q2 is biased on through the front panel POWER

switch at connector 1. Over voltage protection is provided by D1 and Q1. If the DC voltage exceeds 16 Volts, Q1 will become forward biased and keep Q2 from closing the relay. Resistor R5 samples the current delivered to the 100W RF amplifier module. This small voltage drop is cabled through connector 6 to the second mixer board where it is monitored by the ALC circuitry. Connector 2, 3, 4 and 5 distribute +13.5 VDC to other boards.

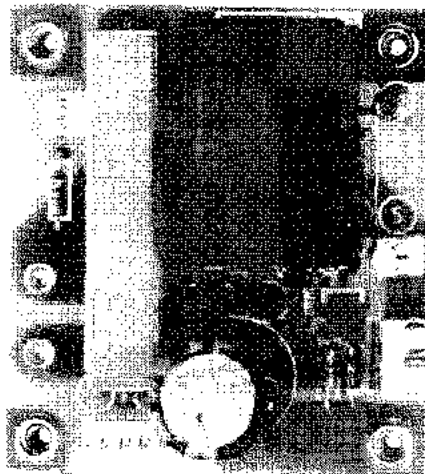

FIGURE 4-21. DC POWER INPUT BOARD COMPONENT LAYOUT (81622)

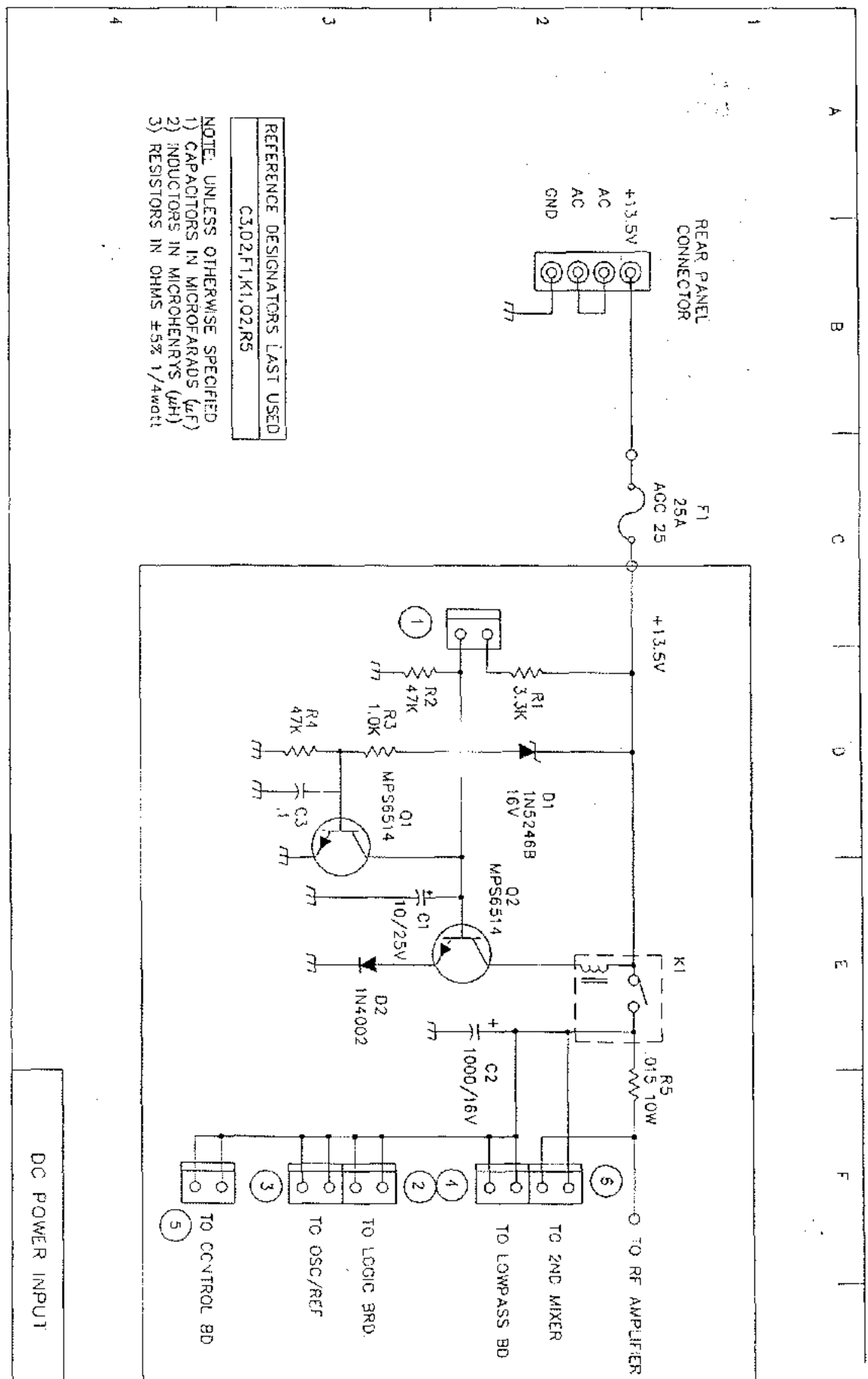

FIGURE 4-22. DC POWER INPUT BOARD SCHEMATIC (81622)

4-13. DB-25 BOARD (81628)

This board contains a female DB-25 connector for communicating with an external computer. Connector X cables send and receive information from and to the RS232 Interface Card at both RS232 and TTL levels. Band line information is also available on this board through connector 8 and is passed on to the lowpass board via connector 7. The six higher frequency lines pass through resistors R1-R6 before going to the DB-25 connector, while one of the lower two Frequency Bands are selected by D1 or D2 and applied to pin 10 of the DB-25 connector.

Pin connections are shown below:

- 1) GND
- 2) A
- 3) B
- 4) NC
- 5) NC
- 6) NC
- 7) NC
- 8) NC
- 9) NC
- 10) .1 - 1.7, 1.7 - 2.5 MHz band lines
- 11) C
- 12) NC
- 13) NC
- 14) NC
- 15) 22 - 30 MHz band lines
- 16) NC
- 17) 15 - 22 MHz band lines
- 18) D
- 19) NC
- 20) NC
- 21) 10.5 - 15 MHz band lines
- 22) NC
- 23) 6.5 - 10.5 MHz band lines
- 24) 2.5 - 4 MHz band lines
- 25) 4 - 6.5 MHz band lines

Where,

	<u>NORM</u>	<u>REV</u>
A	TXD (RS232)	RXD (RS232)
B	RXD (RS232)	TXD (RS232)
C	RXD (TTL)	TXD (TTL)
D	TXD (TTL)	RXD (TTL)

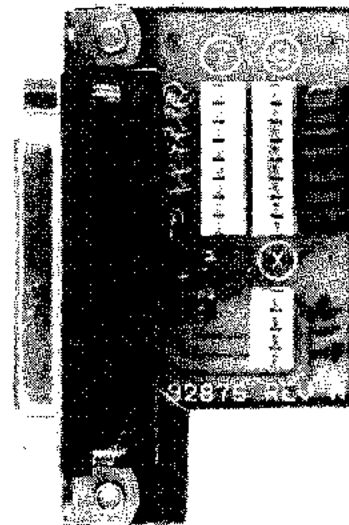

FIGURE 4-23. DB-25 BOARD COMPONENT LAYOUT (81628)

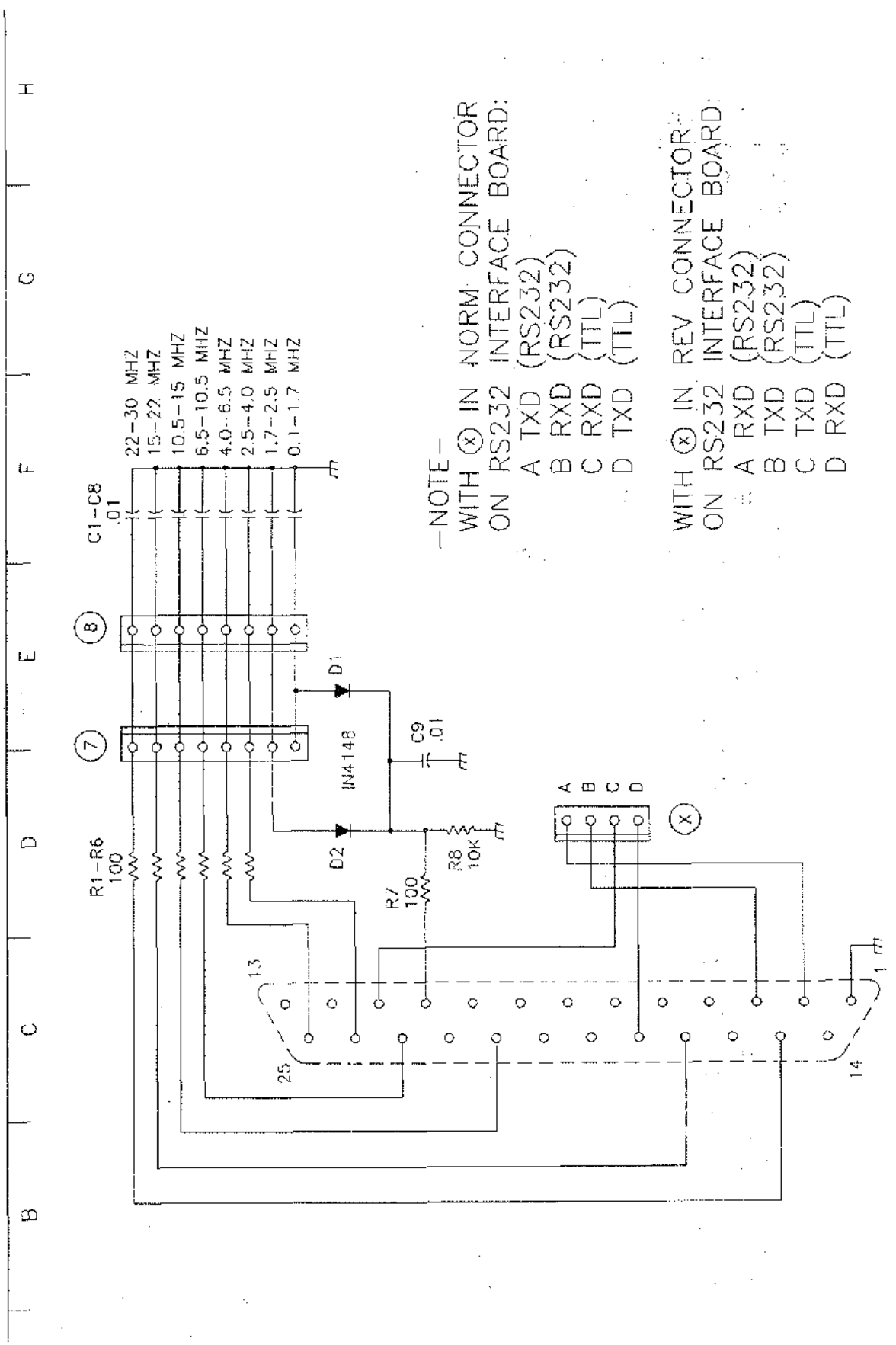

FIGURE 4-24. DB-25 BOARD SCHEMATIC (81628)

-NOTE-
 WITH (X) IN NORM. CONNECTOR
 ON RS232 INTERFACE BOARD:
 A TXD (RS232)
 B RXD (RS232)
 C RXD (TTL)
 D TXD (TTL)

WITH (7) IN REV. CONNECTOR
 ON RS232 INTERFACE BOARD:
 A RXD (RS232)
 B TXD (RS232)
 C TXD (TTL)
 D RXD (TTL)

4-14. SECOND MIXER (81629)

The second mixer board uses the 79 MHz second LO (from oscillator reference connector 27) to perform the frequency conversion between the 70 MHz 1st IF at connector 25 (from the 1st mixer board) and the 9 MHz 2nd IF at connector 38 in receive, or at connector 37 in transmit. It also performs the noise blanker sampling and gating functions for receive, and the ALC function for transmit. Connections to the noise blanker circuit on the low level amplifier board are through connectors 31 and 32. The inputs to the ALC circuit are connectors 29 from the front panel RF PWR control, 12 from the low-pass filter board (FWD), and 6 from the DC power board (ISENSE). This board also contains a 70 MHz 2-pole monolithic crystal filter and 9 MHz AM and SSB 8-pole crystal filters to provide part of the selectivity on receive and the sideband rejection on transmit.

79 MHz from the PLL oscillator reference board drives the LO port of double balanced diode mixer array D28-D31. On receive, a 70 MHz 1st IF signal enters the RF port of the mixer through 15 KHz wide 2-pole monolithic filter Y1. Diode switch D2 is forward biased by "R" voltage from control board connector 35, passing the mixer output to grounded gate amplifier Q1. The 9 MHz output of Q1 is selected by tuned transformers T3 and T4 and coupled to emitter follower Q2 and noise blanker gate circuit T5-T6, D4-D7. Connector 31 carries the output of Q2 to the noise blanker circuit on the low level amplifier board which, when activated, develops a blanking pulse on connector 32. When a blanking pulse drives clamp transistor Q3 into conduction, gate diodes D4-D7 which are normally forward biased by R11 and R12, are reverse biased by the voltage across

C14, blocking passage of the noise pulse to T6. Unblanked signals proceed through T6, T7, and forward biased diode D8 to whichever 9 MHz 8-pole crystal filter is selected by the control board via connector 34. "R" voltage forward biases D18 and reverse biases D16-17 to connect the 9 MHz filter output to the passband tuning board via T8 and connector 38.

In transmit, Diodes D16 and D17 are forward biased by a DC voltage from the TX Audio board on connector 37, connecting the 9 MHz double sideband output of the balanced modulator (or an unbalanced carrier in CW/RTTY) through T8 and D12-D13 to 2.4 KHz sideband filter Y3. The desired sideband is selected by Y3 and passed through D11 and D9, which is forward biased by "T" voltage from control board connector 35, to amplifier and follower Q9 and Q10. The output of emitter follower Q9 drives ALC PIN attenuator diodes D20 and D21. PIN diode D22 is normally biased on in transmit by voltage across zener diode D19, providing a direct path through attenuator R29, R51, R52, and D3 to mixer array D28-D31. Mixer array D28-D31 converts the signal up to 70 MHz and passes it through the 2-pole filter Y1 to the 1st mixer board on connector 25. ALC voltage from the emitter of Q6 forward biases PIN diode D21, shunting part of the 9 MHz transmit signal from Q9 to ground through C48. Also, the forward current of D21 reduces the forward bias of D20, reducing the portion of the signal flowing to C34 and mixer array D28-D31.

* ALC voltage is developed by U1 and U2 based on samples of RF output and PA collector current, and the setting of the front panel RF PWR control. At connector 12, the forward power sample of the SWR bridge on the transmit lowpass filter board passes through R38 to Q4, where it is

compared to a voltage reference set by the RF PWR control through connector 29 and R39. When the forward power sample exceeds the reference voltage, the output of U1A goes up, charging capacitor C30 through D1 establishing an ALC voltage at the base of Q6. The emitter of Q6 follows this ALC voltage to control the attenuation through PIN diodes D20 and D21 as explained above.

Voltage dropped across the PA current sampling resistor on the DC input board is cabled to connector 6 of this board. U2 level shifts this PA current sample and applies it to the input of Q7 which drives the board mounted current limit adjustment R46. When the output of R46 exceeds the reference voltage set by the RF PWR control (factory adjusted to 22 amps with RF PWR fully clockwise), D 23 is forward

biased, and ALC action results similar to the forward power case above. Q5 controls the Front Panel ALC LED at connector 28.

The reflected (reverse) power sample of the SWR bridge from connector 12 is sent to the front panel meter switch through calibration resistor R44, D27, and connector 30. The forward power sample is buffered by U1b to drive peak holding capacitor C40, calibration R45, and meter connector 30. The Ic function of the meter is driven by U2 through calibration R47 and connector 30.

All active stages on this board are powered by "+REG", "R", or "T" from control board connector 36 except for U2 which receives +13.5 Volts from the DC input board at connector 6.

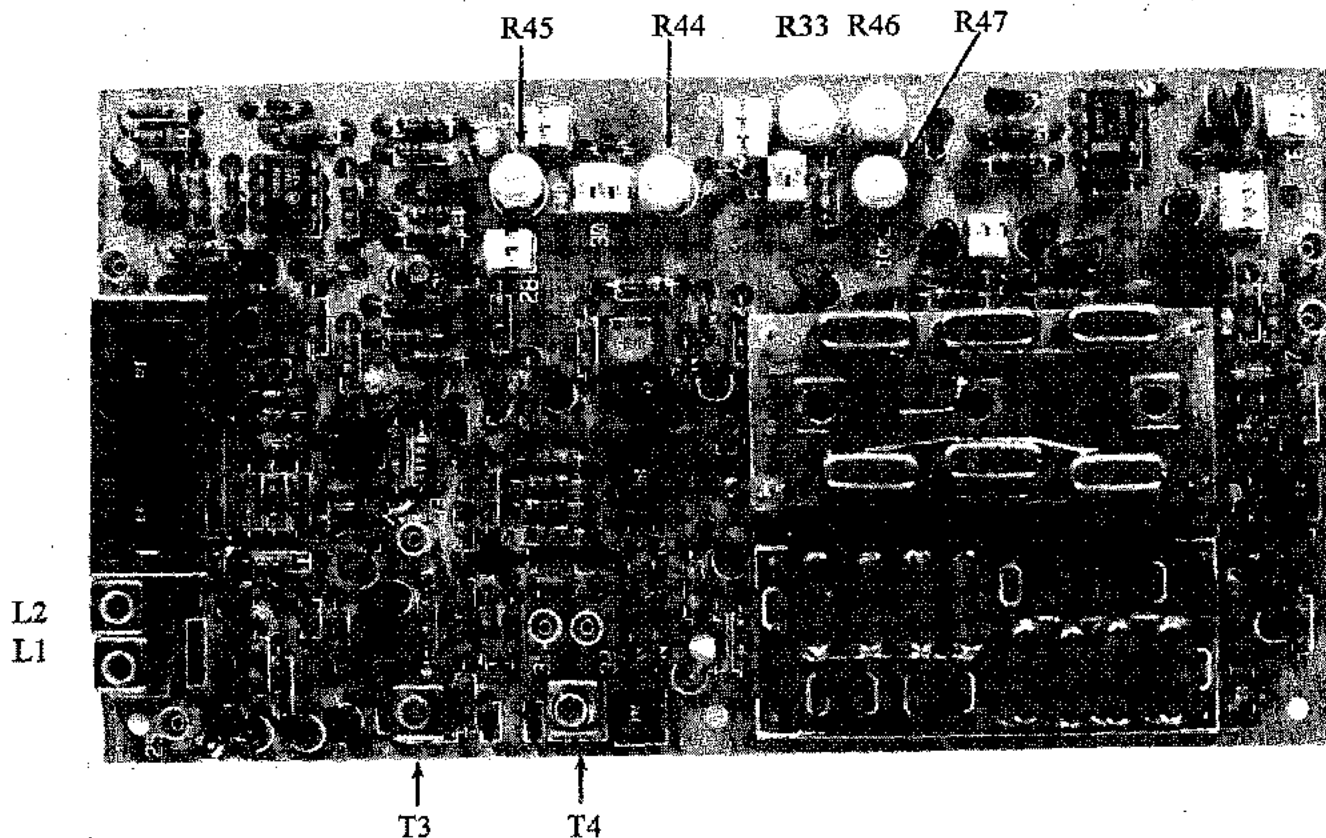
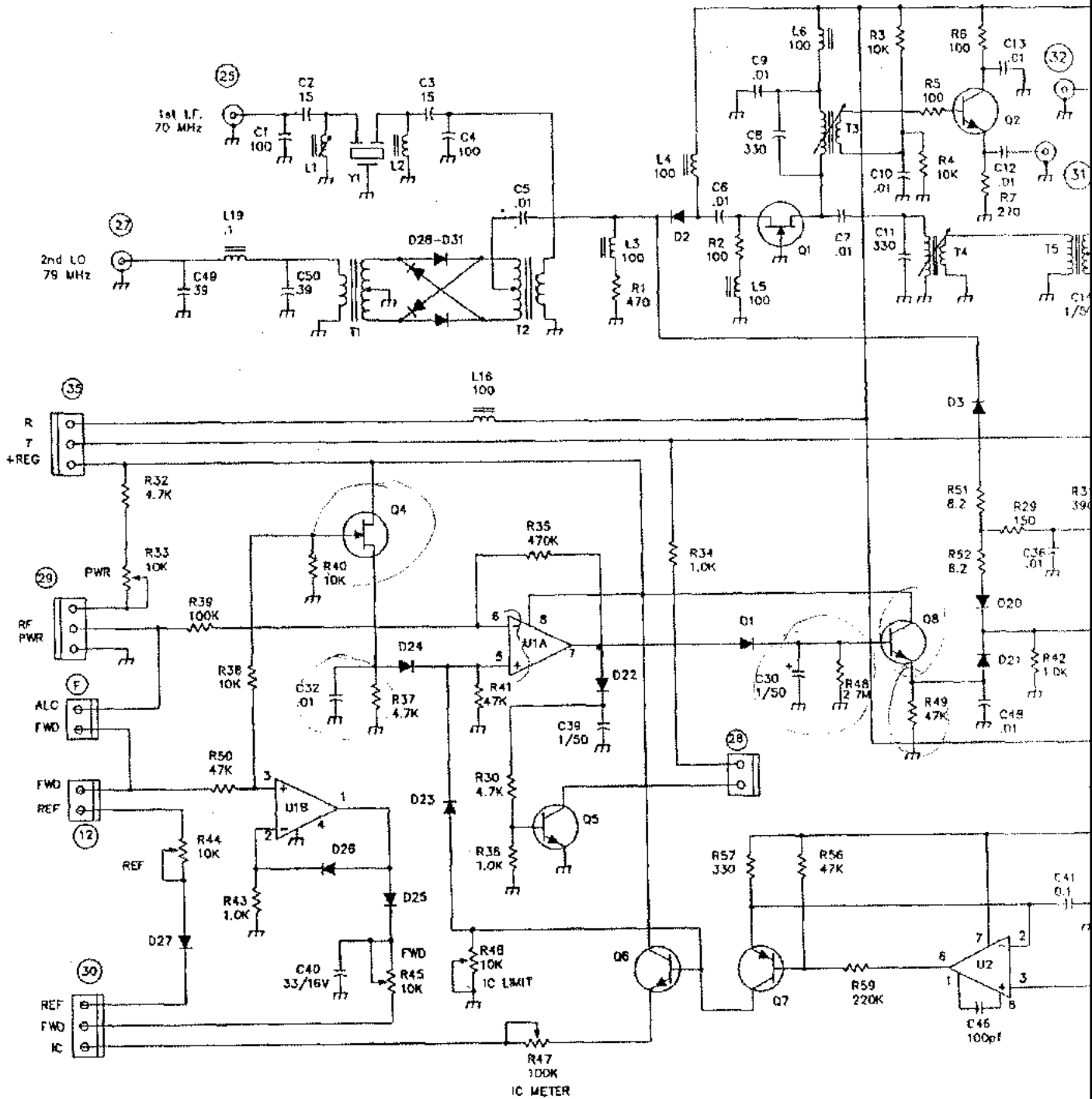

FIGURE 4-25. SECOND MIXER COMPONENT LAYOUT (81629)



REFERENCE DESIGNATORS LAST USED
 C50, R64, Q10, D31, Y3, T9, L19

NOTE: UNLESS OTHERWISE SPECIFIED
 1) CAPACITORS IN MICROFARADS (μF)
 2) INDUCTORS IN MICROHENRYS (μH)
 3) RESISTORS IN OHMS ±5% 1/4watt

Q1, Q4
 Q2
 Q3, Q5, Q6
 Q7
 Q8
 Q9, Q10
 U1
 U2

J310
 MPS5179
 MPS6514
 ZNS087
 MPSA14
 2N4124
 LM359N
 LM301AN

D1
 D2-D18
 D19
 D20, D21
 D22-D27
 D28-D31

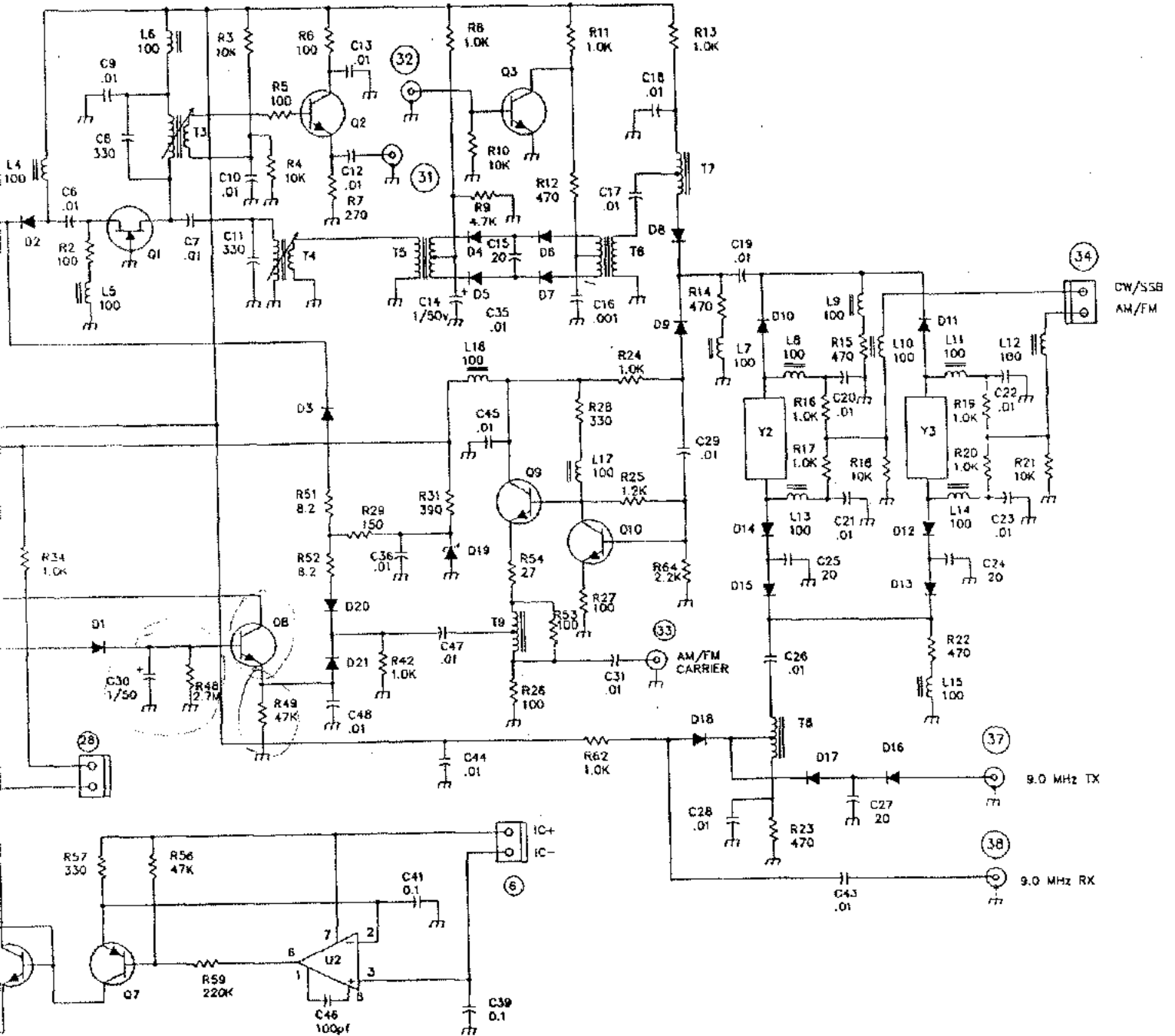

04
2
0, OS, Q6
7
8
9, Q10
1
2

J310
MP55179
MP56514
ZN5087
MP5A14
2N4124
LM358M
LM301AN

D1
D2-D18
D19
D20, D21
D22-D27
D28-D31

1N4148
BA452
1N751A
1P3379
1N4148
MBD101

Y1 70MHz, 2 POLE, 15Kc BW
Y2 9MHz, 8 POLE, 2.4Kc BW
Y3 9MHz, 8 POLE, 6Kc BW

4-26. SECOND MIXER SCHEMATIC (81629)

4-15. FIRST MIXER (81630)

This board contains the receiver functions of RF amplifier, 1st mixer, monolithic filter, and filter post amplifier. It also performs the transmit functions of transmit mixer and low level preamplifier. It accepts receiver input from the receive bandpass filter board at connector 17 and produces a 70 MHz IF output to the second mixer board at connector 25 and a transmit signal on the operating frequency is output to the low level driver board on connector 24.

The receive input at connector 17 passes through PIN attenuator diode D5 and diode switch D6 to the RF amplifier Q1-Q4. D5 is normally forward biased by the two diode drops across D1 and D2, but this bias can be overcome by forward current through PIN diode D4 produced by large signal AGC voltage from the IF/AF board on connector 19. Four junction FETs are paralleled in the broadband RF amplifier stage to provide high dynamic range, greatly reducing the level of interfering intermodulation products from nearby large signals in the band. Diode switch D8 connects the RF amplifier output to the input of the high level single balanced 1st mixer Q5-Q6.

Transistor Q11 and diode switches D7 and D16 provide bypassing of the RF amplifier when the transceiver is in the AM broadcast band (.1-1.7 MHz). On bands other than .1-1.7 MHz, the base of Q9 is pulled low by R6 via connector 16. The forward biased Q9 then supplies power to the RF amplifier through L4, forward biasing diode switches D6 and D8 and reverse biasing diodes D7 and D16. When the .1-1.7 MHz band is selected, connector 16 supplies 12.5 Volts to the base of Q11 and Q9 which forward biases diodes D7 and D16, reverse biasing D6 and D8. This re-

moves power from the RF amplifier and bypasses it through the -10dB pad resistors through D7 and D16. This produces an overall attenuation of -20dB when the transceiver is between .1-1.7 MHz.

First mixer transistors Q5 and Q6 mix the receive signal in the .1-30MHz range with the synthesizer 1st LO output of 70.1-100 MHz to produce the first IF at 70 MHz. Tuned transformer T4 couples the 70 MHz mixer output through -3dB pad R20-R22 to diode switch D9 which is forward biased in receive by "R" voltage from connector 20. The -3dB pad serves to stabilize impedance variations and terminate mixer products at the mixer output port, improving distortion performance of the mixer and the match to the crystal filter. Tuned matching networks C20-C22 and L8-L9 couple the 70 MHz IF signal through a 15 KHz wide 2 pole monolithic crystal filter and into the 1st IF amplifier stage Q7. L20 matches the output of Q7 to 50 Ohms and diode D12 routes the signal to the 2nd mixer board via connector 25.

In transmit, "T" voltage from connector 20 powers transmit mixer U1 and forward biases diode switches D10, D11, and D14, reverse biasing D9 and D12. The monolithic filter and IF amplifier now process the 70 MHz transmit IF signal from the 2nd mixer board at connector 25 and feed it to one input of transmit double balanced mixer U1. U1 mixes the 70 MHz IF with the synthesizer output of 71.7 to 100 MHz to produce and output on the operating frequency in the range of 1.7-30 MHz. This signal passes through 30 MHz lowpass filter C36-C38, L17-L18 to the input of broadband amplifier Q8. The output of Q8 is matched to 50 Ohms by T7 and normally passes through diode switch D14 to the transmit low level amplifier board via connector 24. However, when the transverter enable pin of connector 23

is pulled low by grounding the center pin of the rear panel XVRT EN connector, transistor switch Q10 supplies a forward current to D13 which reverse biases D14 so that the output of Q8 is diverted through -3dB pad R47-R49 to the rear panel XVRT OUT connector via connector 22. This output is useful for driving transmitting

frequency converters which require an input level of approximately +5dBm in the 1.7-30 MHz band.

To ensure that no stray signals leak in from the receiver input connector 17 during transmit, diode D3 is included to bias up the AGC attenuator diode D4 while "T" voltage is high.

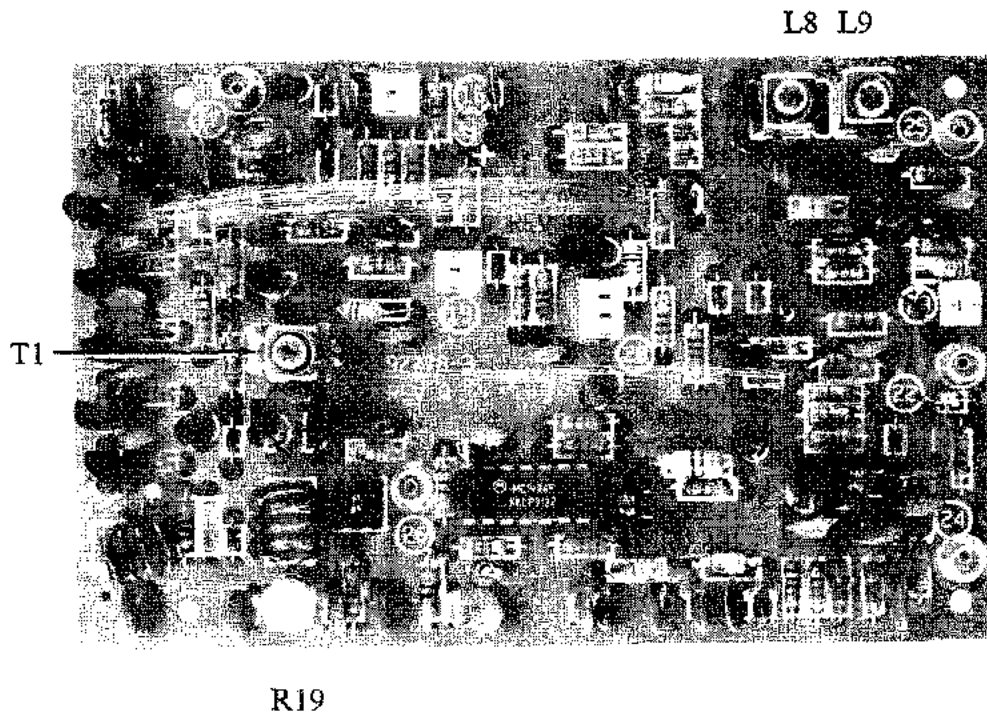
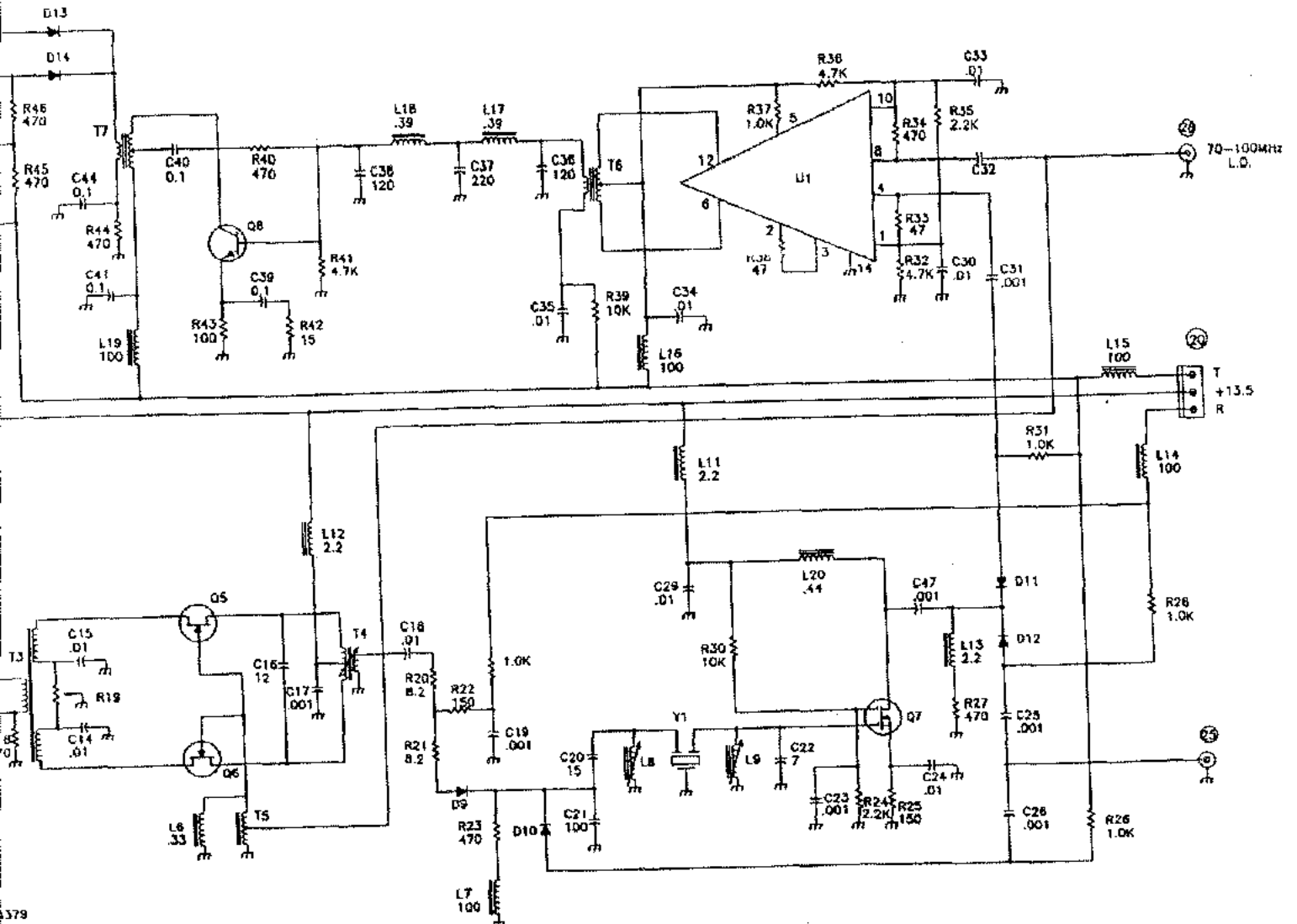
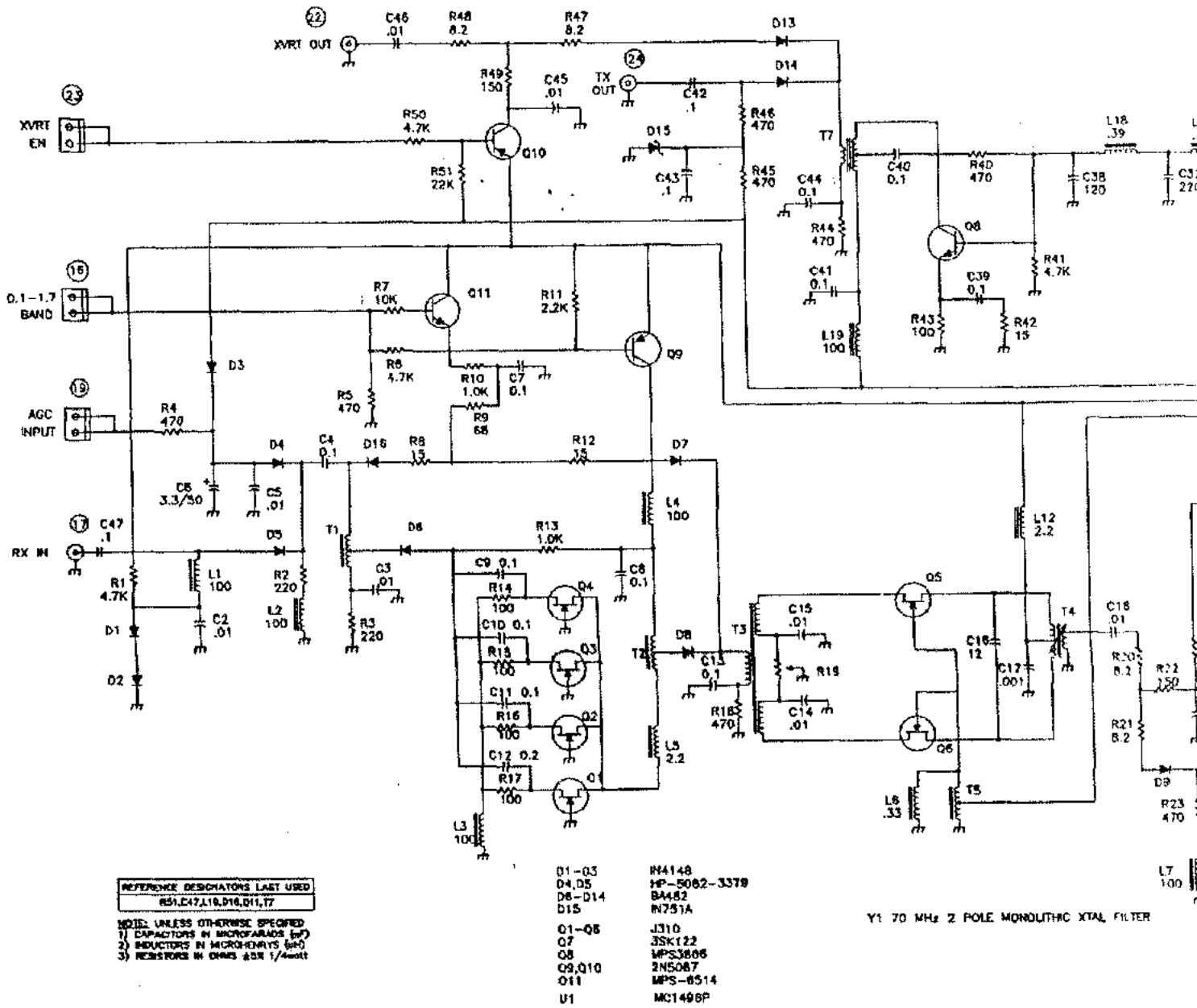

FIGURE 4-27. FIRST MIXER COMPONENT LAYOUT (81630)



Y1 70 MHz 2 POLE MONOLITHIC XTAL FILTER

FIGURE 4-28. FIRST MIXER SCHEMATIC (81630)



4-16. PASSBAND TUNING BOARD (81631)

The passband tuning board accepts a 9 MHz receive IF signal from the 2nd mixer board at connector 38, converts it down to approximately 6.3 MHz and passes it through one of four crystal filters (the 2.4 KHz filter is standard). Filter select lines from logic board connector 41 determine which filter is selected. After filtering, the signal is converted back to 9 MHz and sent to the IF/AF board via connector 43. The exact frequency of the signal before filtering is set by the front panel PBT control through connector 42.

The 9 MHz IF signal from the 2nd Mixer at connector 38 occupies a 2.4 KHz wide band (9.0003-9.0027 MHz) on SSB/CW and RTTY, and a 6 KHz band (8.997-9.003 MHz) on AM/FM. This signal is amplified by low noise amplifier Q1 and input to the RF port of the diode mixer made up of D1-D4. The LO port of this mixer is driven with approximately 15.3 MHz from VCXO Q4 through buffer Q5 and LO amplifier Q3. The exact frequency of the LO signal is determined by the bias on tuning diode D5 which is set by the front panel PBT control through connector 42. The output of the VCXO is also buffered by Q6 and used as the LO signal to the output mixer Q9. This arrangement insures that the IF signal exits the PBT board on exactly the same frequency as it entered, regardless of the VCXO frequency.

As an example of passband tuning board operation, it will be assumed that the receiver is operating in USB mode with the 2.4 KHz filter selected. With the PBT control centered, Q4 oscillates at 15.3 MHz, producing an output of 6.2973-6.2997 MHz from diode mixer D1-D4. This matches exactly the passband of the

2.4 KHz sideband filter which is selected by diode switches D6, D7 and D8. In this condition the 8-pole response of the 2.4 KHz filter on the 2nd mixer board to produce an overall 16-pole IF filter response of 2.4 KHz bandwidth for the receiver. If the PBT control is rotated counter-clockwise, the frequency of the VCXO goes down (as much as 1.6 KHz for fully CCW) moving the output frequencies of mixer D1-D4 down in relation to the passband of the 2.4 KHz filter on this board, filtering out some of the lower frequencies in the 2.4 KHz band width mixer output signal. This effectively reduces the IF bandwidth of the receiver by the amount of the frequency shift of the VCXO. This reduced bandwidth signal is now mixed again with the VCXO in Q9 to return the remaining signals to their original frequencies. The end effect of this is that, as the PBT control is rotated counter-clockwise, the original 2.4 KHz USB passband is progressively reduced by as much as 1.6 KHz, and the reduction is accomplished by moving the upper edge of the passband downward, reducing the higher frequency audio tones of the received signal. Rotating the PBT control clockwise from center again reduces the passband, but this time the reduction is accomplished by shifting the lower passband edge upward, reducing the lower frequency audio tones.

The operation of passband tuning with other modes or filters selected is similar to the above except that in LSB the direction of control rotation is reversed with respect to audio frequency response (to preserve the correspondence of control movement to the frequency location of the received signals), and narrow filters have less usable range of shift. In AM/FM mode, an attenuator is selected by D20, D21, and D22 instead of a filter, so passband tuning has no effect.

Power to the output mixer Q9 is supplied through Q8 which is forward biased during receive by Q7. The input preamplifier Q1 and bias to VCXO Q4 are supplied by "R" voltage from control board connector 39. Regulated "+REG" voltage supplies the VCXO and buffers Q3 and Q5. The remaining stages are powered by 13.5 Volts from connector 39.

R18

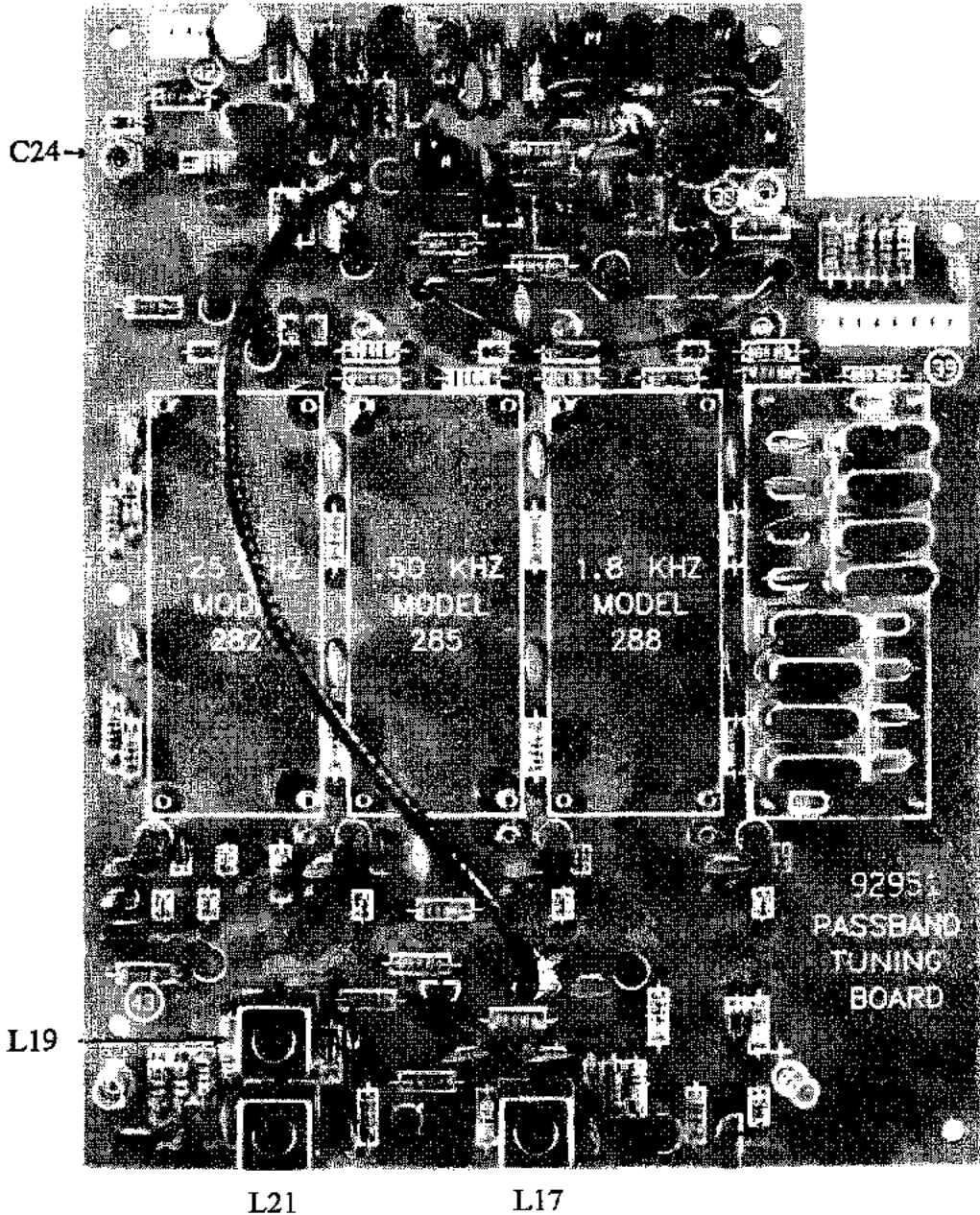

FIGURE 4-29. PASSBAND TUNING BOARD COMPONENT LAYOUT (81631)

“Great sounding rig! Must be a Ten-Tec.”

All the Ten-Tec rigs that I've owned have excelled in audio. I owned a pair of (other brand) transceivers but Ten-Tec beats them in transmit audio - K4NTY

Great audio! Full, rich, natural! - K4TEN

Good audio quality and it sounds like my natural voice - K6WLM



Excellent audio. I was working a station in Puerto Rico and he stopped the calling stations and asked me what I was running. I told him the Jupiter and he said “I should have known it was a Ten-Tec.” - WD4PG

I'm confident that I will have the best signal I can possibly produce! - W1RGO



I am amazed how clean and clear I sound - W4WUQ



Very well balanced audio; natural sounding, pleasing to listen to. One of the best sounding rigs on the band. Well rounded with clarity. - KA4ICK

I get great unsolicited audio reports with the Ten-Tec Orion - WA8VSJ

Hearing is everything.

What separates one rig from another? The way they sound on the air. When you hear quality SSB transmit audio, you know it's Ten-Tec. No one matches our combination of great audio, ease of use, and receiver performance. Visit our webpage at radio.tentec.com/videos/howto and see an audio and video demo on Ten-Tec transceiver transmit audio! For complete information on our HF transceiver line, visit our website or call (800) 833-7373.

Proudly made in Sevierville, Tennessee USA

www.tentec.com

1185 Dolly Parton Pkwy., Sevierville, TN 37862. Sales: 800-833-7373 M-F 8:00-5:30 (Eastern Time) sales@tentec.com. Office: (865) 453-7172. FAX: (865) 428-4483. Service: (865) 428-0364 M-F 8:00-5:00 (Eastern Time), service@tentec.com. We accept Visa, MC, American Express and Discover.

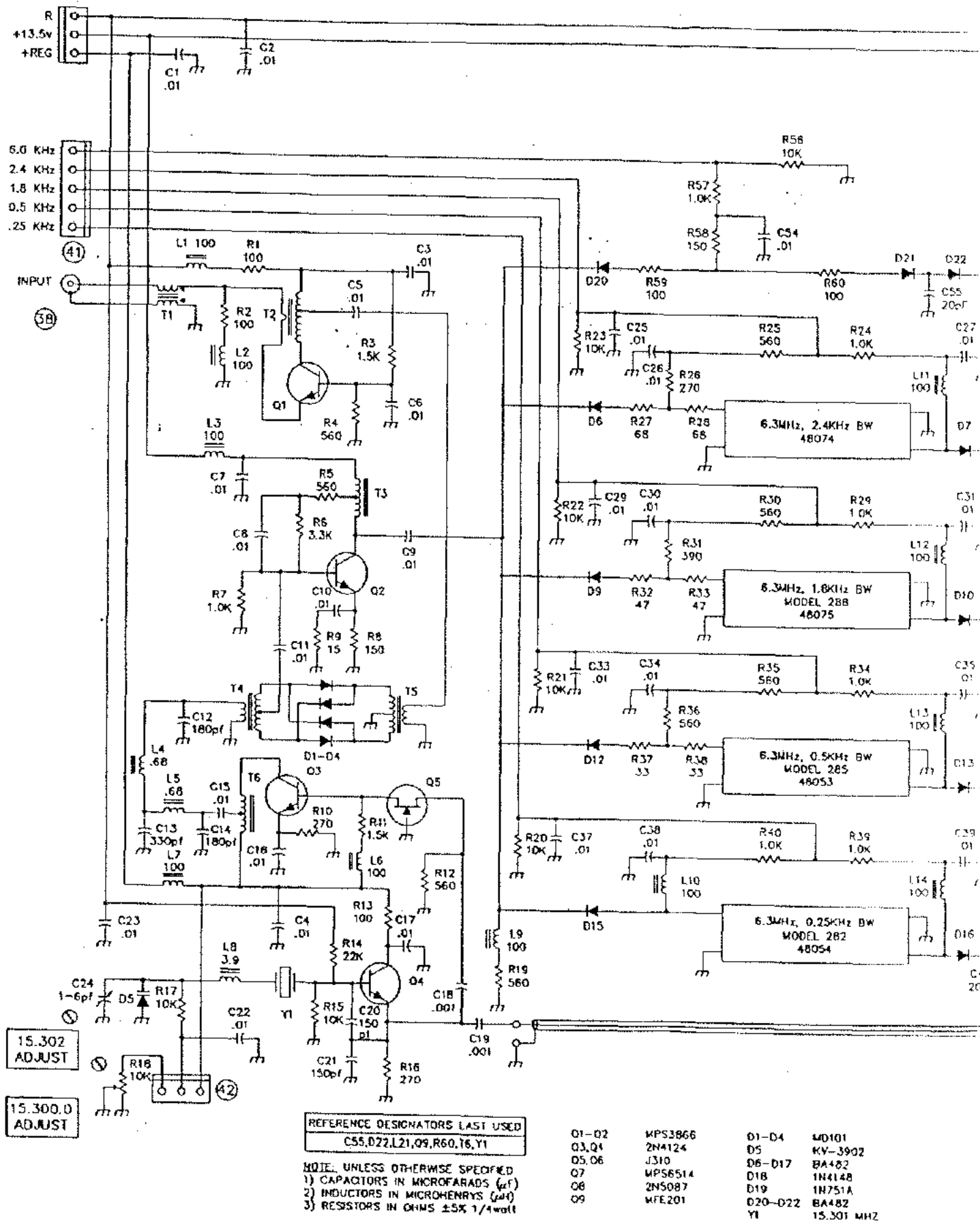

Part No. 74242
October 1993
Printed in U.S.A.

FIGURE 4-30. PASSBAND TUNING BOARD SCHE

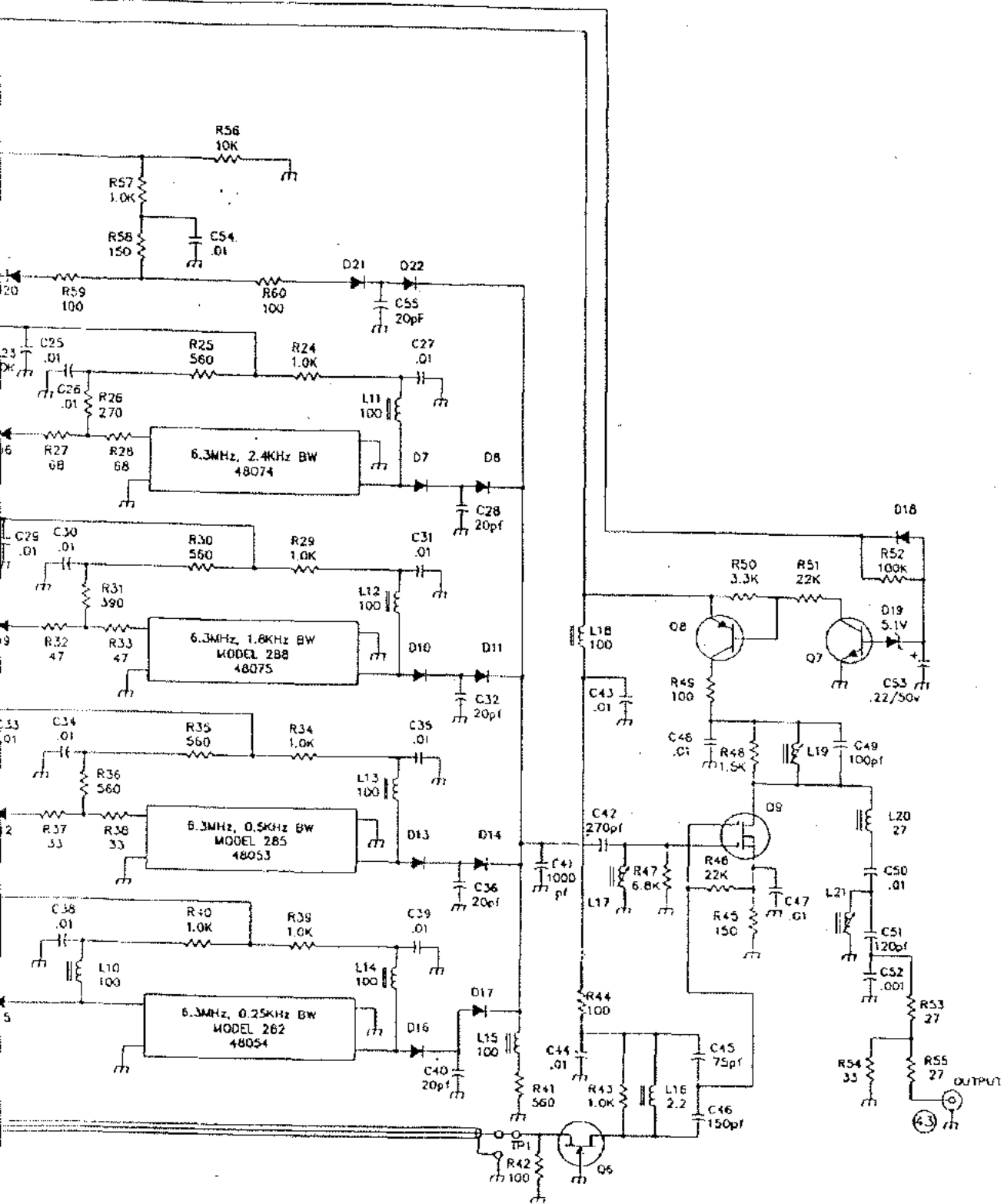

D2	WPS38G6	D1-D4	MD101
D4	2H4124	D5	KV-39Q2
D6	J310	D6-D17	6A482
	WPS6514	D18	1N4148
	2NS087	D19	1N751A
	WFC201	D20-D22	6A482
		V1	15.301 MHz

4-17. IF/AF BOARD (81632)

The IF/AF board contains the 9 MHz IF amplifier stages that contribute the major portion of the receiver gain. It also contains the SSB/CW, AM, and FM detectors, AGC circuits, audio notch and bandpass filters, audio amplifier and speaker driver.

The 9 MHz IF signal from the passband tuning board enters at connector 43 and is amplified by grounded gate FET Q1, integrated circuit IF amplifiers U1 and U2, and emitter follower Q3. The output of Q3 splits three ways. One output drives AGC detector D4-D6, to develop and AGC voltage across capacitor C45. Through connector 49, the front panel AGC FAST/SLOW switch connects additional AGC holding capacitor C46 in parallel with C45 in the SLOW position, and the AGC ON/OFF switch shorts the AGC voltage to ground in the OFF position. U9b amplifies and level shifts the AGC voltage and, through D8, applies it to the gain control pins of U1 and U2 and the base of PIN diode driver Q2. Shunt PIN diode D1 attenuates the IF signal at the input to U1 when the amplified AGC voltage exceeds the threshold set by zener diode D2. The front panel RF GAIN control at connector 50 can reduce receiver gain by raising the AGC control line voltage through Q7 and D12.

The AGC voltage across C45 is also amplified and level shifted by S-meter amplifier U9a and split two ways: to the S-meter through D11 and R57 and to the front end AGC diodes on the 1st mixer board via connector 19. A mute voltage from control board connector 44 saturates Q12 during transmit and for a short period after transmit as determined by C64-C65-R89 and the front panel QSK switch at connector 48.

Another output from emitter follower

Q3 drives AM IF amplifier Q5 and AM detector Q4. The detected AM output of Q4 is filtered by C33, C34, and R32 and applied to one section audio switch U4.

The last output from Q3 is via C20 to product detector U3. The approximately 9 MHz BFO input to the product detector comes from the AM/FM board via connector N. The detected SSB/CW/RTTY output from the product detector is filtered by C26, C27, and R17 and applies to a section of audio switch U4.

Based on inputs from the control board on connector 51, audio switch U4 selects an audio signal from the product detector in SSB/CW/RTTY mode, the AM detector in AM mode, or the AM/FM board at connector U in FM mode. The output of U4 drives notch filter circuit U5. The frequency of the audio notch is determined by the clock frequency input to U5 which is developed by notch clock circuit U6. The frequency of notch clock U6 is set by the front panel NOTCH control via connector 53. The frequency range of the notch clock is approximately 27-210 KHz resulting in an audio notch frequency range of 540-4200 Hz. The output of notch filter U5 drives the audio bandpass filter circuits U7 and U8 through C42, and one side of the front panel FADE control through C43 and connector 55. Q11 samples a portion of this "flat" audio and outputs it to the rear panel AUDIO OUT jack via connector 56 and the transmit audio board.

The center frequency of the audio bandpass filter is determined by the voltage applied to R71 and R84 by the front panel BP control via connector 54. The center frequency range of the bandpass filter is approximately 220-1700 Hz, and the 6 dB bandwidth is always 35% of the center frequency. Bandpass filtered audio output from U8 is routed to one side of the front panel FADE control through C52 and con-

nector 55.

On the upper pot board, the unfiltered (flat) audio from C43 and the bandpass filtered audio from C52 are combined in proportions determined by the setting for the front panel FADE control. Clockwise rotation of the control increases the filtered portion and decreases the unfiltered portion of audio delivered to audio amplifier U10a through connector 55, R91, and C57.

The receive audio (or transmit audio from sidetone connector 57) is amplified by U10a and applied to the clockwise end nector 55. The counter-clockwise end of

the control returns through connector 55 to the input of speaker driver U10b. C54 shunts the wiper of the control to ground, forming a "high cut" tone control. Cable 47 connects the speaker driver output to the front panel PHONES jack and the rear panel EXT SPKR jack. Cable 76 carries it from there to the sidetone board, cable 77, and the internal speaker.

Cable 44/45 from the control board provides the +13.5 volts needed for U10 and "+REG" needed for all other circuit stages.

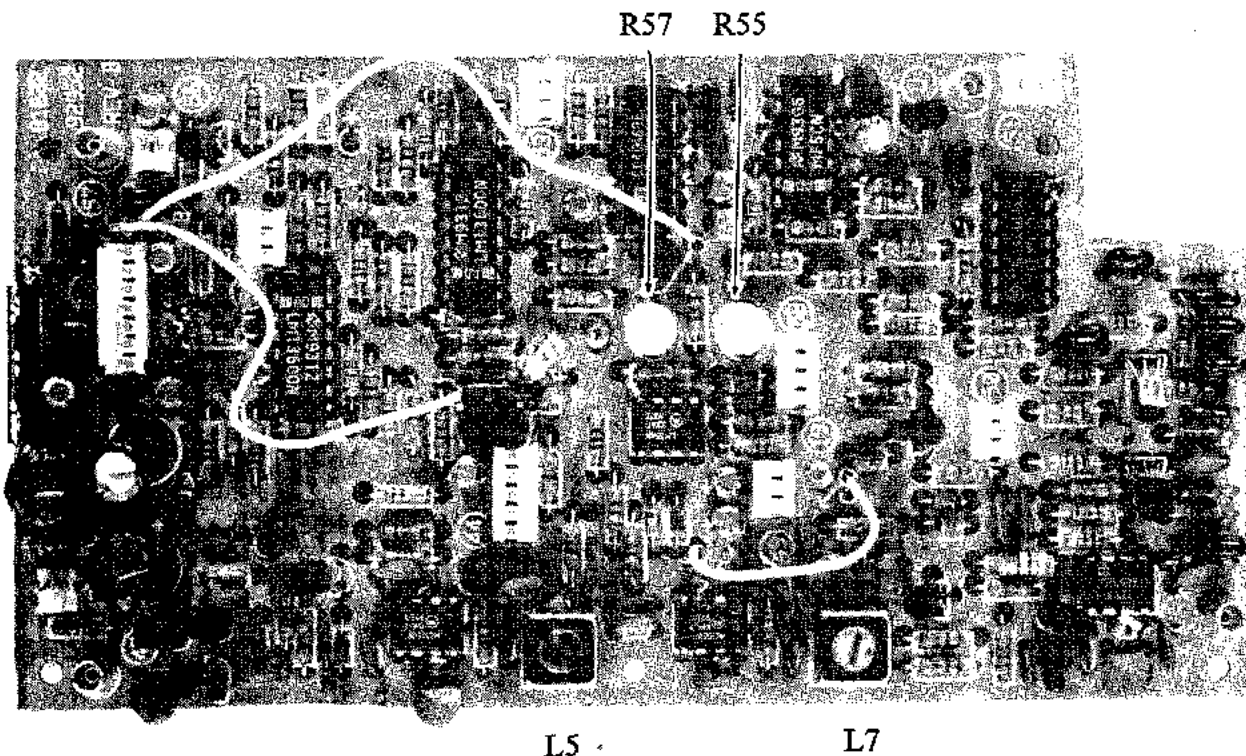
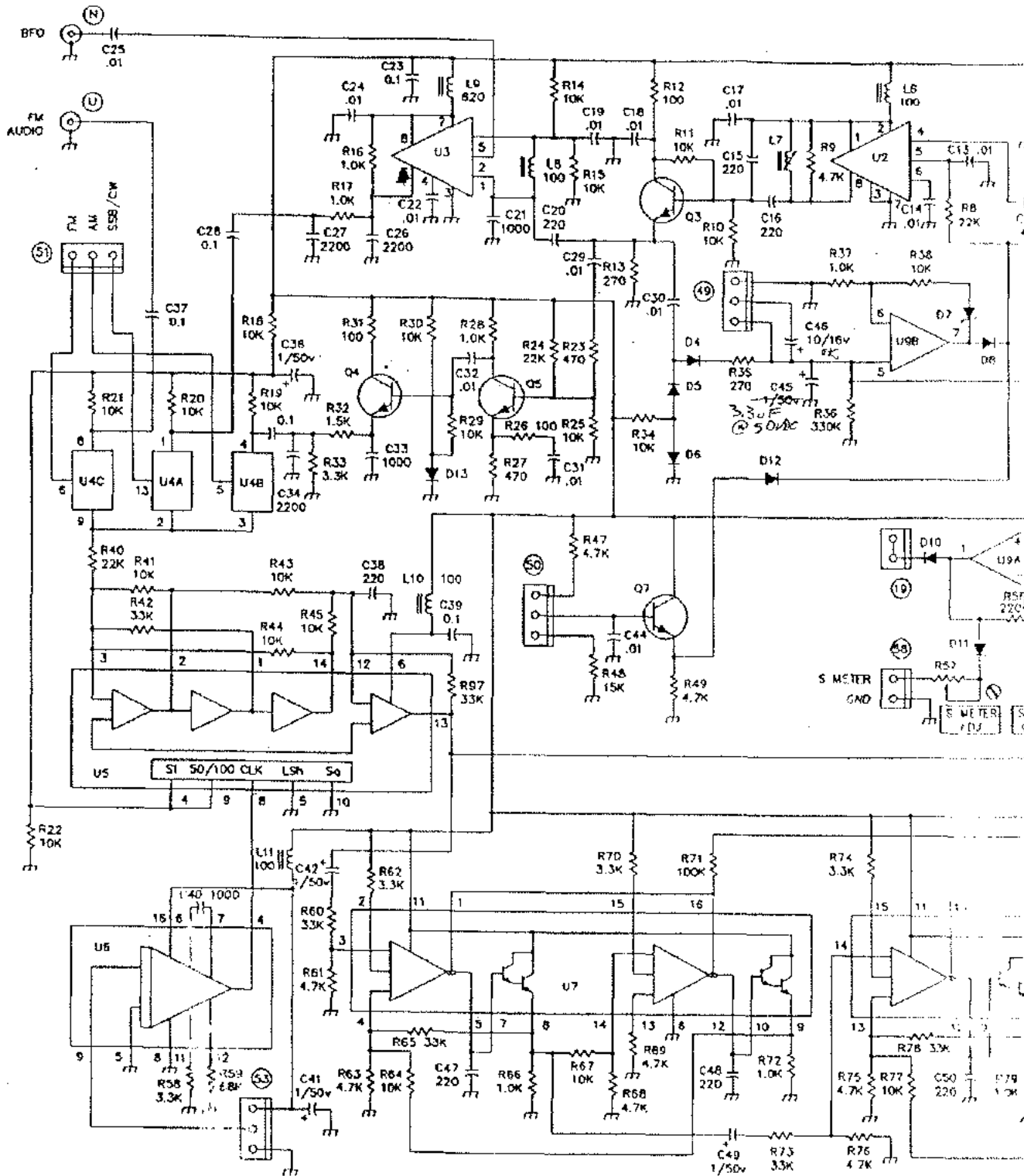

FIGURE 4-31. IF/AF BOARD COMPONENT LAYOUT (81632)



REFERENCE DESIGNATORS LAST USED
 R100, C71, L12, D11, C710

NOTE: UNLESS OTHERWISE SPECIFIED
 1) CAPACITORS IN PICOFARADS (PF)
 2) INDUCTORS IN MICROHENRYS (UH)
 3) RESISTORS IN OHMS ±5% 1/4W

U1, U2	MC1350P	D1	J310	D1	HP 5529
U3	CA3053E	D2, D4, D5	WPS6514	D2-D7	1N748A
U4	CD4068E	Q7, Q11	WPS6514	D4, D5	1N4148
U5	WFSCH	C3	WPS3693	D8, D10-D13	1N4148
U6	CD4046BE	Q12	WPSU01	D6	BA141
U7, U8	LM13600N				
U9	LM358N				
U10	TDA1015				

FIGURE 4-32. IF/AF BOARD SCHEMATIC (8)

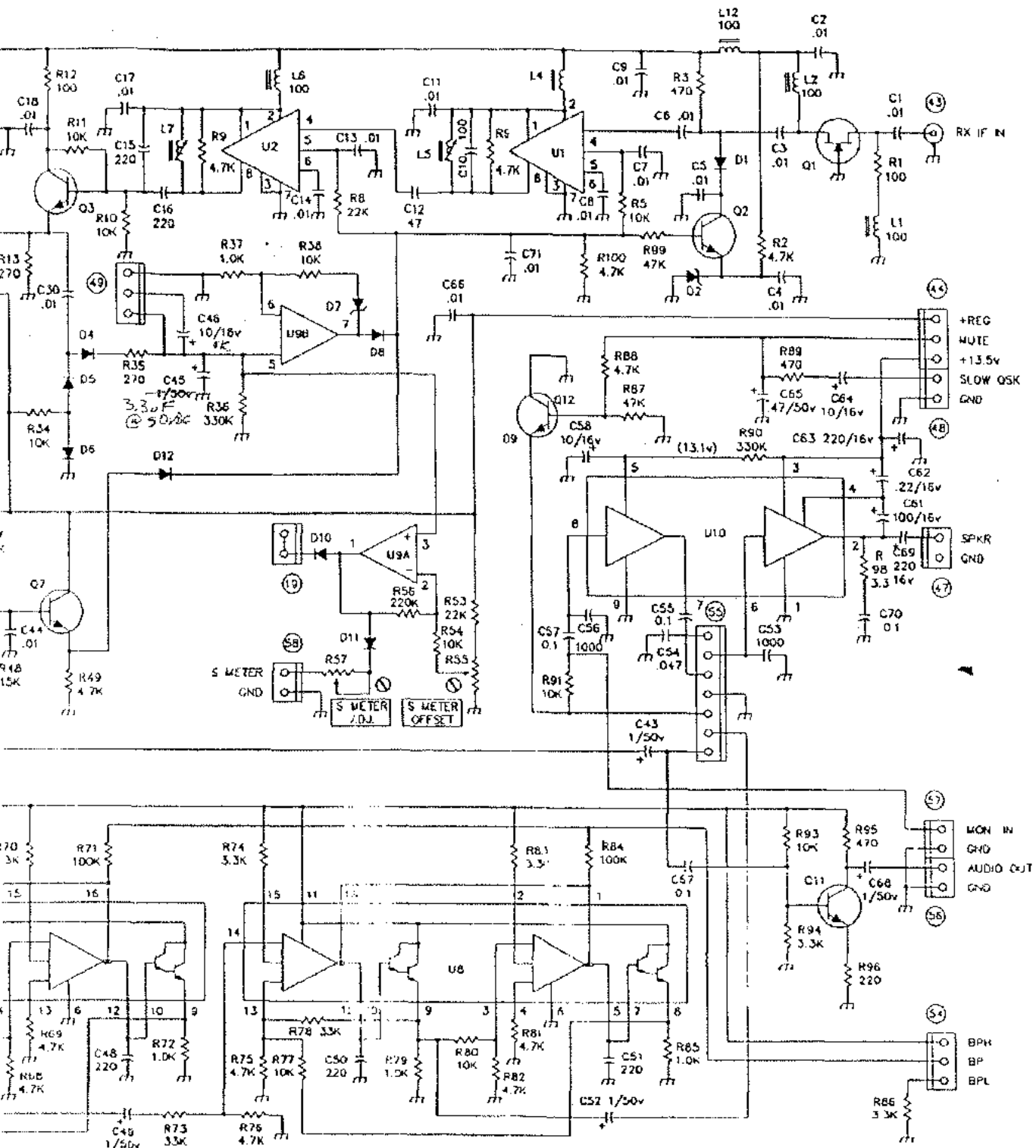

- | | | | |
|------------|---------|-------------|---------|
| Q1 | J310 | D1 | HP 3379 |
| Q2, Q4, Q5 | MPS6514 | D2-D7 | 1N748A |
| Q7, Q11 | MPS6514 | D4, D5 | 1N4148 |
| Q3 | MPS3693 | D8, D10-D13 | 1N4148 |
| Q12 | MPS1101 | D6 | BA141 |

586	IF/AF BOARD	81632
-----	-------------	-------

FIGURE 4-32. IF/AF BOARD SCHEMATIC (81632)

4-18. LOW LEVEL AMPLIFIER/ NOISE BLANKER (81633)

This board contains the low level wide-band amplifier for the transmitter, the receiver noise blanker, "T" and "R" voltage generator, and the "+REG" and meter lamp regulators. It is located on the left upper chassis on top of the PLL shield behind the FM/AM board.

The operating frequency transmit signal from the first mixer board enters on connector 24, is amplified by class A amplifier transistors Q15 and Q16, and exits to the final power amplifier at connector 79. During transmit, "T" voltage supplies bias to both stages through R39 and R44.

"T" and "R" voltages are developed by Q2, Q5-6, and Q10-14 based on the level of the "TD" pin from control board connector 62. In transmit "TD" is high and Q14 sources approximately 12.5 Volts to the "T" line through R32, while Q10 holds the "R" line low. In receive "TD" is low and Q13 sources approximately 8.5 Volts to the "R" line through R38 while Q11 holds the "T" line low.

At connector 31, a sample of the 9 MHz receive IF signal from the second mixer board is input to noise blanker amplifiers U1 and U2. Part of the output of U1 is sent to FM receive audio output connector T.

The output of U2 is split two ways. Part of the signal is fed through C5 to Q3 which provides the AGC control of U2. This helps to maintain a constant output level from U2 when there is no noise present or when the noise pulse widths are long. The N.B. pot is located in the upper left hand corner of the transceiver (N.B. width) and controls the emitter voltage of Q1 through connector R. The output of Q1 is summed with the AGC voltage from Q8 and sets the noise threshold of the noise blanker system. The other output of U2 goes to pulse amplifiers Q4 and Q9 whose output appears at connector 32. This output signal consists of noise pulse components with fast rise and fall times, which are applied to a noise gate circuit on the 2nd mixer board to blank the receiver during noise pulse intervals.

A regulator composed of U4 and Q6 supplies 8.5 Volts "+REG" voltage to all boards via connector 62 and the control board. Q6 is mounted on the PLL shield plate and connected with cable Q. Meter lamp regulator U5 is likewise mounted to the PLL shield and connected with cable P. Regulated 6 Volts is supplied to the meter lamps through connector O.

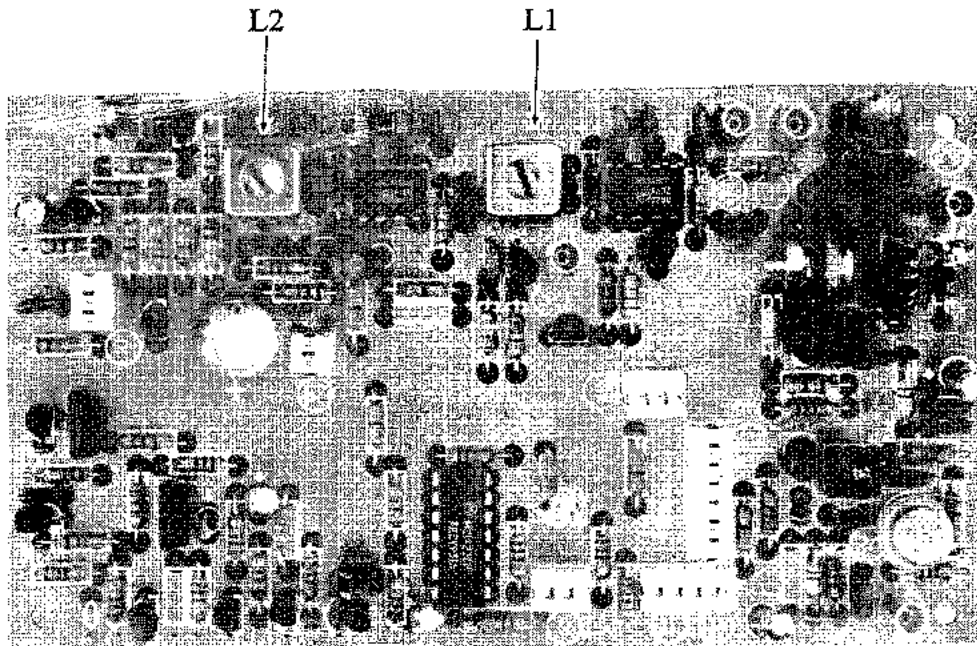

FIGURE 4-33. LOW LEVEL AMPLIFIER/NOISE BLANKER COMPONENT LAYOUT (81633)

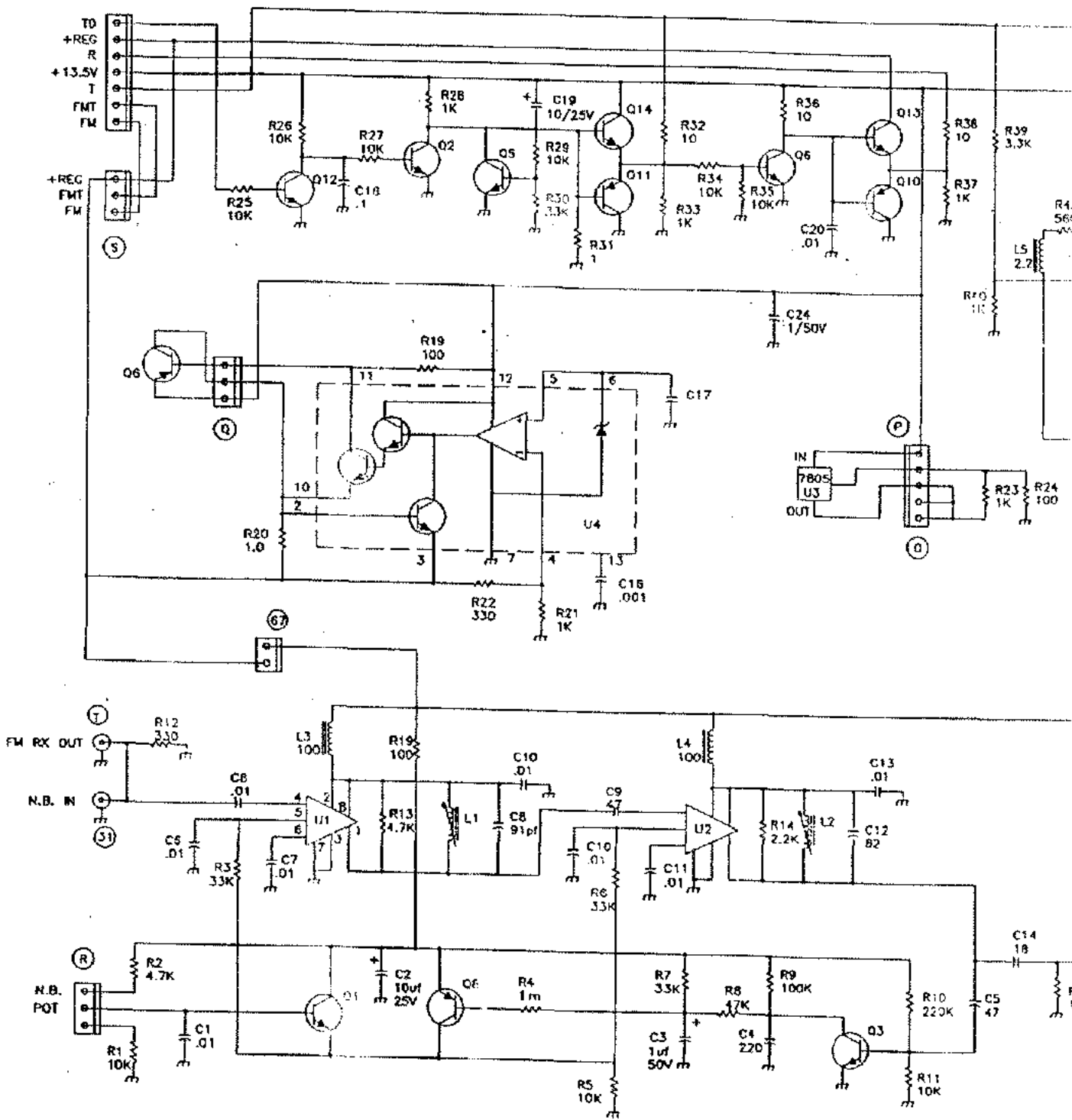
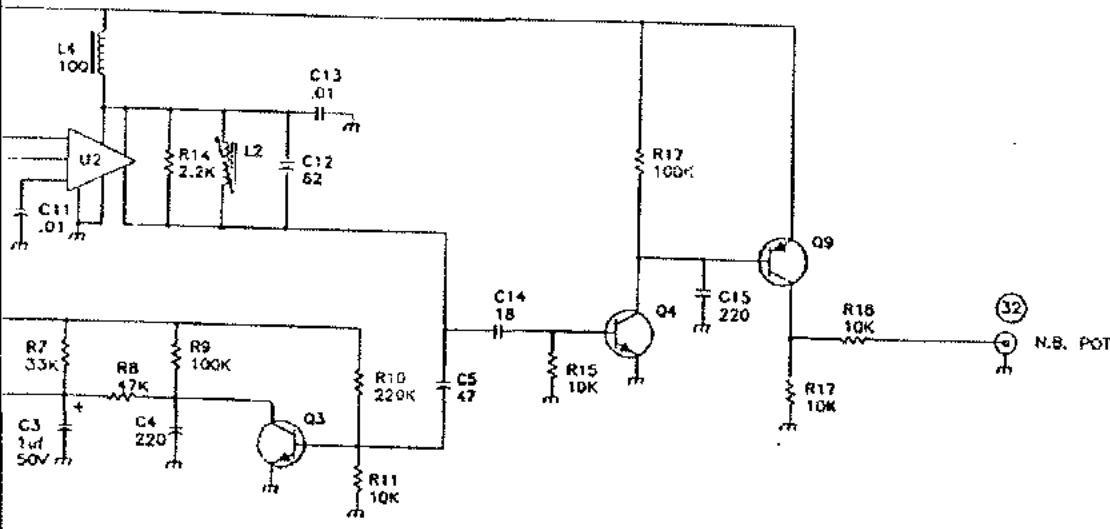
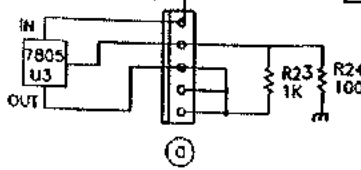
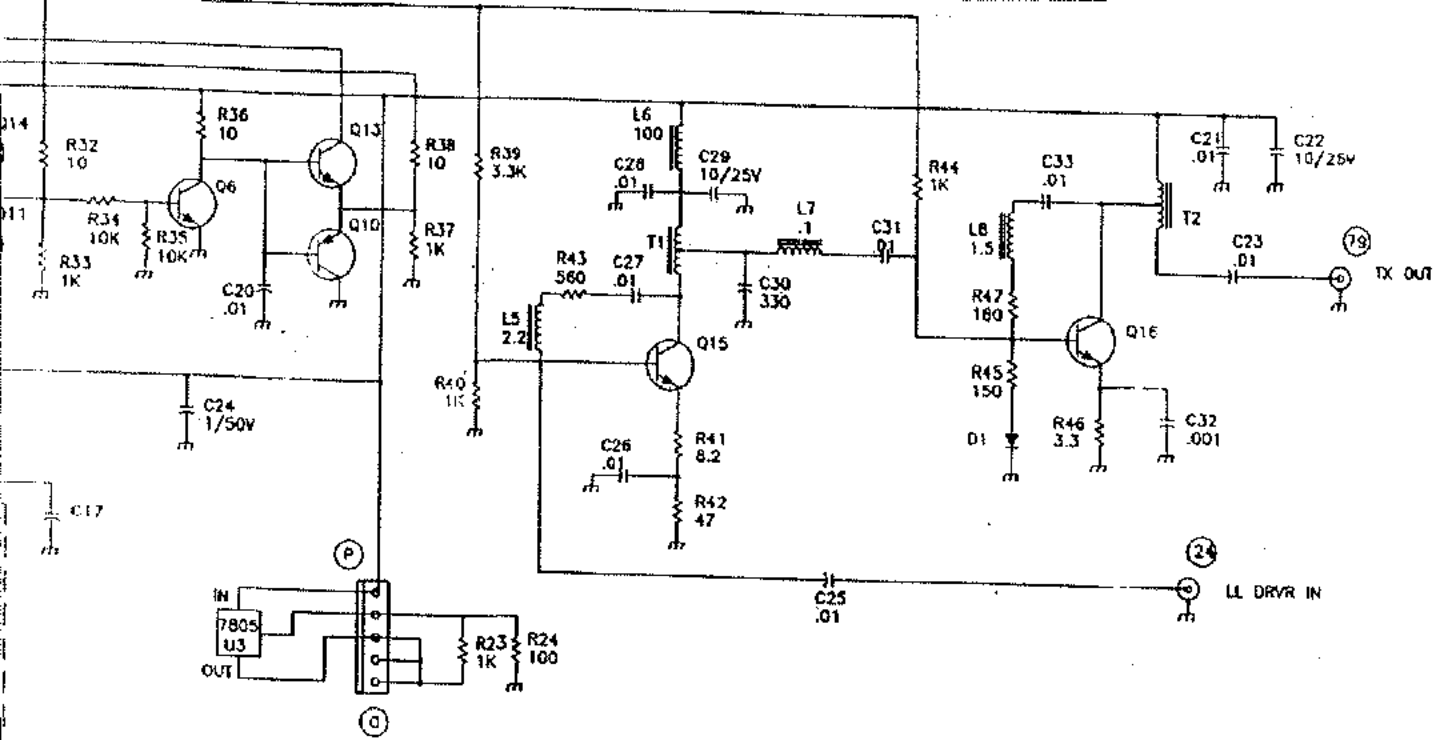

FIGURE 4-34. LOW LEVEL AMPLIFIER/NOISE B



- Q1-Q7 MPS6514
- Q8-Q11 2N50E7
- Q12 MJE370
- Q13-Q14 MPSV01
- Q15 2N3866
- Q16 2SC1969

- D1 K4002

- U1-U2 MC1350
- U3 7805CT
- U4 MC1723CP

REFERENCE DESIGNATORS LAST USED
 C33, R47, Q16, D1, T2, L6, L8

NOTE: UNLESS OTHERWISE SPECIFIED:
 1) CAPACITORS IN MICROFARADS (μF)
 2) INDUCTORS IN MICROHENRYS (μH)
 3) RESISTORS IN OHMS ±5% 1/4watt

LOW LEVEL DRIVER/NOISE BLANKER BOARD

34. LOW LEVEL AMPLIFIER/NOISE BLANKER SCHEMATIC (81633)

4-19. TRANSMIT AUDIO/BFO BOARD (81634)

This board contains the transmit audio amplifiers, speech processor and VOX circuit, the 9 MHz BFO and balanced modulator. It is located at the left rear of the chassis, on top of the chassis deck behind the PLL shield box. Board mounted controls for VOX DELAY, VOX GAIN, and ANTI-VOX, and phono connectors for AUDIO IN and OUT and XVRT ENable and OUT are accessible through the rear panel.

Microphone audio from connector 73 or transmit audio from the rear panel AUDIO IN jack is amplified by U2B. The output of U2B splits four ways to drive the anode of diode switch D18, FM audio output connector 75, the speech PROCCESSOR control pot at connector 74, and the VOX GAIN control R64. Diode D18 is normally forward biased through connector 70 when the PROCCESSOR switch on the lower pot board is in the off position, connecting the amplified audio signal to the MIC gain control at connector 71.

The speech processor input at connector 74 is amplified to a nominal 1.2 Volts peak by U3A and again by U3B to approximately 1.8 Volts peak. One output of U3B drives rectifier D15 and compressor transistor Q13. Q13 clamps part of the original input to ground, effectively maintaining a constant audio level at the output of U3A. Another output of U3B drives the processor level meter through emitter follower Q12 and connector 78.

Half the output of U3A appears across clipper diodes D16 and D17, but no clipping occurs at the normal level of 0.6 volts. The clipper diodes limit fast audio transients, for which the compressor circuit is less effective, to 0.65-0.7 Volts. The compressed and limited speech proc-

essor output level is set by R81, and U4A buffers the output to the anode of diode switch D19. When the PROCCESSOR switch is in the ON position, D18 is reverse biased, D19 is forward biased, and processed audio is passed to the MIC gain control via connector 71. R18 is adjusted so that the peak levels of the processed and the unprocessed audio signals at connector 71 remain equal as the PROCCESSOR switch is toggled between OFF and ON.

The output of the MIC gain control at the center pin of connector 70 is buffered by U4B and output to the balanced modulator U5 and to the MONITOR level control on the sidetone board via connector 72.

The balanced modulator mixes the transmit audio signal from U4B with the BFO carrier to produce a 9 MHz double sideband suppressed carrier output. U5 is enabled on pin 7 by "TD" voltage from the control board connector 60. The balanced modulator gain is increased in SSB mode by grounding bypass capacitor C24 through Q9. Q10 unbalances the modulator in CW and RTTY modes. Tuned transformer T1 performs the match to the 50 Ohm DSB input of the 2nd mixer board at connector 37. R38 and R39 trim the AC and DC balance of U5 for maximum carrier null.

The VOX circuit is formed by U1, U2A, and Q11. Transmit audio from U2B is divided by VOX GAIN control R64 and amplified by U1B to drive positive voltage doubler D9-D10. Anti-VOX in put (speaker audio) on connector 72 is divided by ANTI VOX control R66 and amplified by U2A to drive negative voltage doubler D11-D12. The voltage doubler outputs are summed into comparator U1A by resistors R73 and R74. Whenever the sum at U1A pin 3 is more positive than the reference voltage at U1A pin 2, the com-

parator output goes high, charging C57 and saturating VOX keying transistor Q11. When the PTT/VOX switch on the switch board is in the VOX position, Q11 keys the transmitter via switch board connector 68 and control board connector 65. VOX DELAY control R79 sets the hold-in time of the VOX circuit by determining the discharge rate of C57.

The BFO oscillator/amplifier is formed by transistors Q6-Q8, and its frequency of operation is determined by crystals Y1-Y2, diode switches D20-D24, and capacitors C3-C10. Based on the mode of operation, transistor switches Q1-Q5 drive the diodes which select trimmer capacitors to set the BFO frequency at the proper place with respect to the IF filter response.

Mode information from the control board enters at connector 60. The trimmers can be set with a high resolution counter at connector 46 by switching modes in the order listed below and adjusting the corresponding trimmer for the frequency indicated:

RTTY (shift CW) transmit, with MARK/SPACE low, adjust C6 for 9.000875 MHz.

RTTY transmit, with MARK/SPACE high, adjust C10 for 9.000705 MHz.

RTTY receive for LSB, adjust C4 for 9.003000 MHz.

USB, adjust C7 for 9.000000 MHz.

CW transmit or TUNE, adjust C9 for 9.000700 MHz.

NOTE: RTTY MARK input voltage can be in the range of 0 to -15 Vdc. RTTY SPACE input voltage should be in the range of +2.5 to +15 Vdc for proper operation.

Because of a slight interaction between the trimmers, these adjustments should be repeated at least once.

The BFO output from Q7 splits three ways. One output drives ALC transistor Q8 which controls the bias of oscillator transistor Q6 to maintain a constant output level. Another output serves as the carrier input to the balanced modulator U5. The third BFO output drives the product detector on the IF/AF board through connector 46.

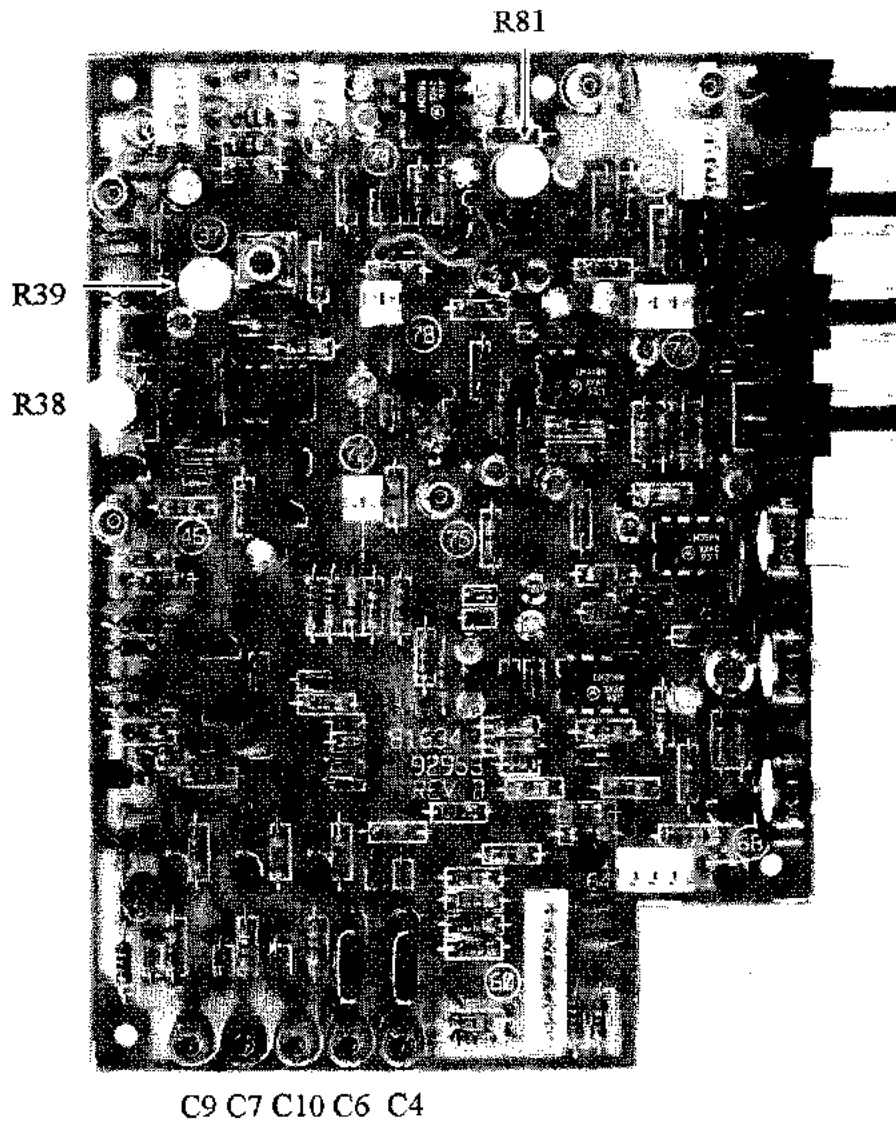

FIGURE 4-35. TRANSMIT AUDIO/BFO COMPONENT LAYOUT (81634)

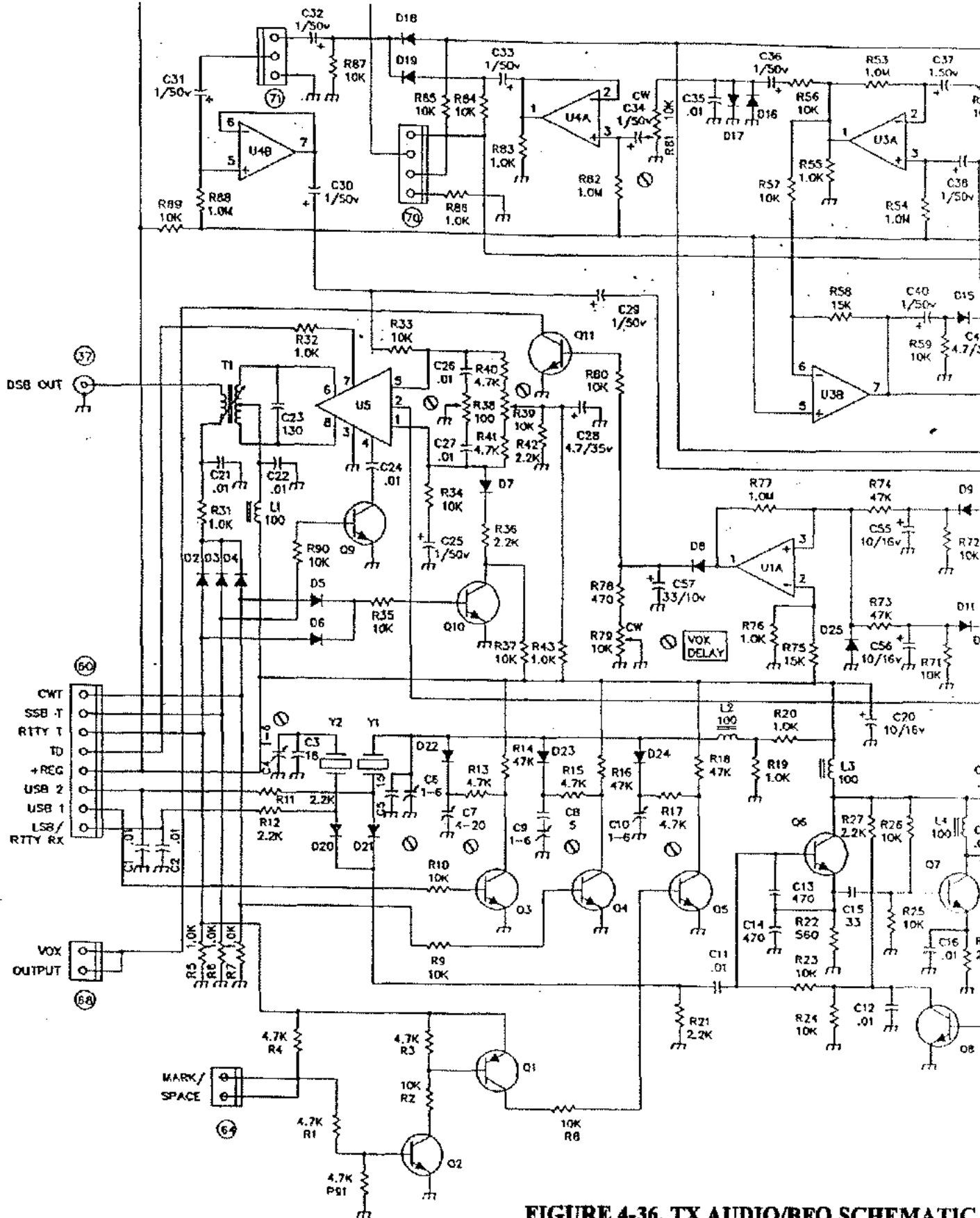

FIGURE 4-36. TX AUDIO/BFO SCHEMATIC

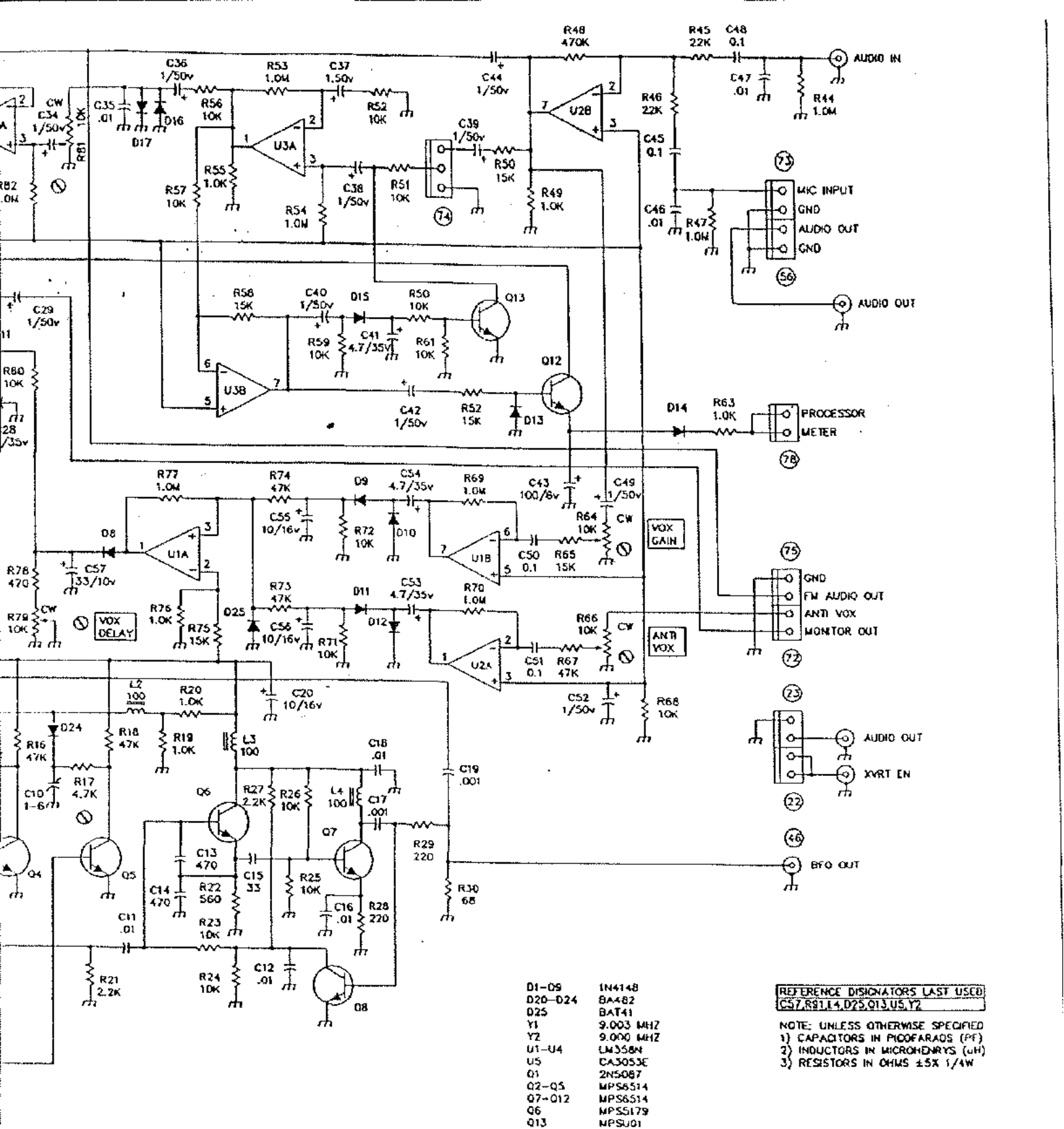

FIGURE 4-36. TX AUDIO/BFO SCHEMATIC (81634)

4-20. AM/FM BOARD (81635)

This board contains the circuitry necessary for AM and FM carrier generation in transmit, and a narrowband FM IF chip for FM signal processing in receive.

In FM transmit, audio enters on connector 75 and passes through opamp U2A where the audio signal is amplified. This stage provides preemphasis with a high pass response of typically +6dB/octave over the audio range. The signal then goes to the limiter stage made up of diodes D3 and D4. This circuit stage is pre-set to allow a maximum of +/- 5 KHz deviation. The next stage, an audio lowpass filter, filters the audio signal. It is at this point the FM carrier is generated. D6 and D7 perform a voltage to frequency conversion in the oscillator circuit made up of Y2 and Q8. The oscillator isolation is provided by Q9. The generated FM transmit carrier passes through diode D8 and exits on connector 33 where it travels to the 9 MHz IF stage for frequency conversion.

In AM transmit (AM-USB or AM-LSB), the BFO enters on connector 46, passes through diode D11 and is amplified by transistor stage Q7. The signal then passes through diode D9 and exits on connector 33 where it is reinserted in the 9 MHz IF stage for further processing and frequency conversion. The FWD voltage, which is a voltage representing output power level, enters on connector F. This voltage is used along with U3B to level the carrier output.

In FM receive, the signal is obtained at 9 MHz from the Low Level Driver/Noise Blanker Board and travels to the AM/FM Board via connector T. The signal enters U1 and a MC3371P FM receiver chip, which performs frequency conversion down to a 455 KHz IF. There is a 455KHz ceramic filter that sets the receiver band-

width for the built-in detector. T1 is a 455 KHz tuned circuit that is used to recover the maximum audio with little distortion. The lowpass network of C2, C35, and R7 perform deemphasis for the audio just before it is passed on to the IF/AF Board via connector U. The audio signal also passes through R8 and C5 to pin 10 of U1, which contains an internal opamp used as a noise triggered squelch. Output of the internal opamp at pin 11 is routed through C3 to D1 and through connector 52 to the front panel mounted SQUELCH control. When the amplitude of the audio is below the level set by the squelch control, diode D1 conducts and pulls pin 12 low, allowing U1 to mute the audio output. Pin 13 of U1 provides an S-meter output control current. This current is proportional to the logarithm of the IF input signal amplitude, and is fed to buffer transistor Q3. Diode D2 is used to compensate for the base-emitter voltage drop of Q3, and the potentiometer R12 is used to calibrate the S-meter reading. S-meter output from Q3 is sent through connector V to the front panel meter switch.

ALIGNMENT

FM RECEIVE: With a 9 MHz (+/- 5 KHz deviation) FM signal present at connector T, adjust T1 for an audio peak with a dB meter. Next, set FM signal amplitude at 50 mV RMS and adjust R12 for an S-meter reading of S9.

FM TRANSMIT: With no audio present and the PARAGON II in FM mode, and a frequency counter plugged into connector 33, key the radio. Adjust R31 for 8.998.500 MHz.

AM TRANSMIT: With the radio in AM-USB or AM-LSB, a wattmeter and a dummy load connected, key the radio. Adjust R44 for 50W reading on wattmeter.

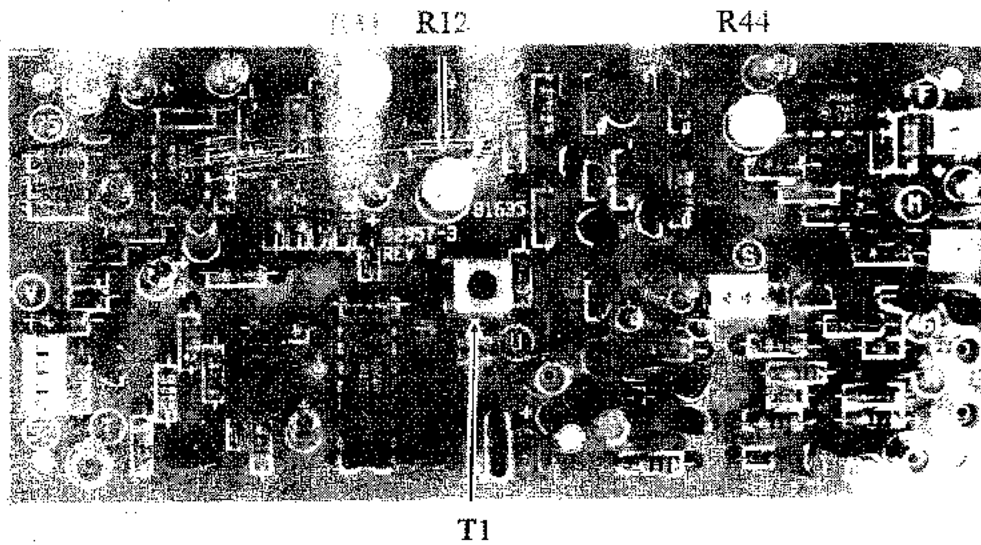

FIGURE 4-37. AM/FM BOARD COMPONENT LAYOUT (81635)

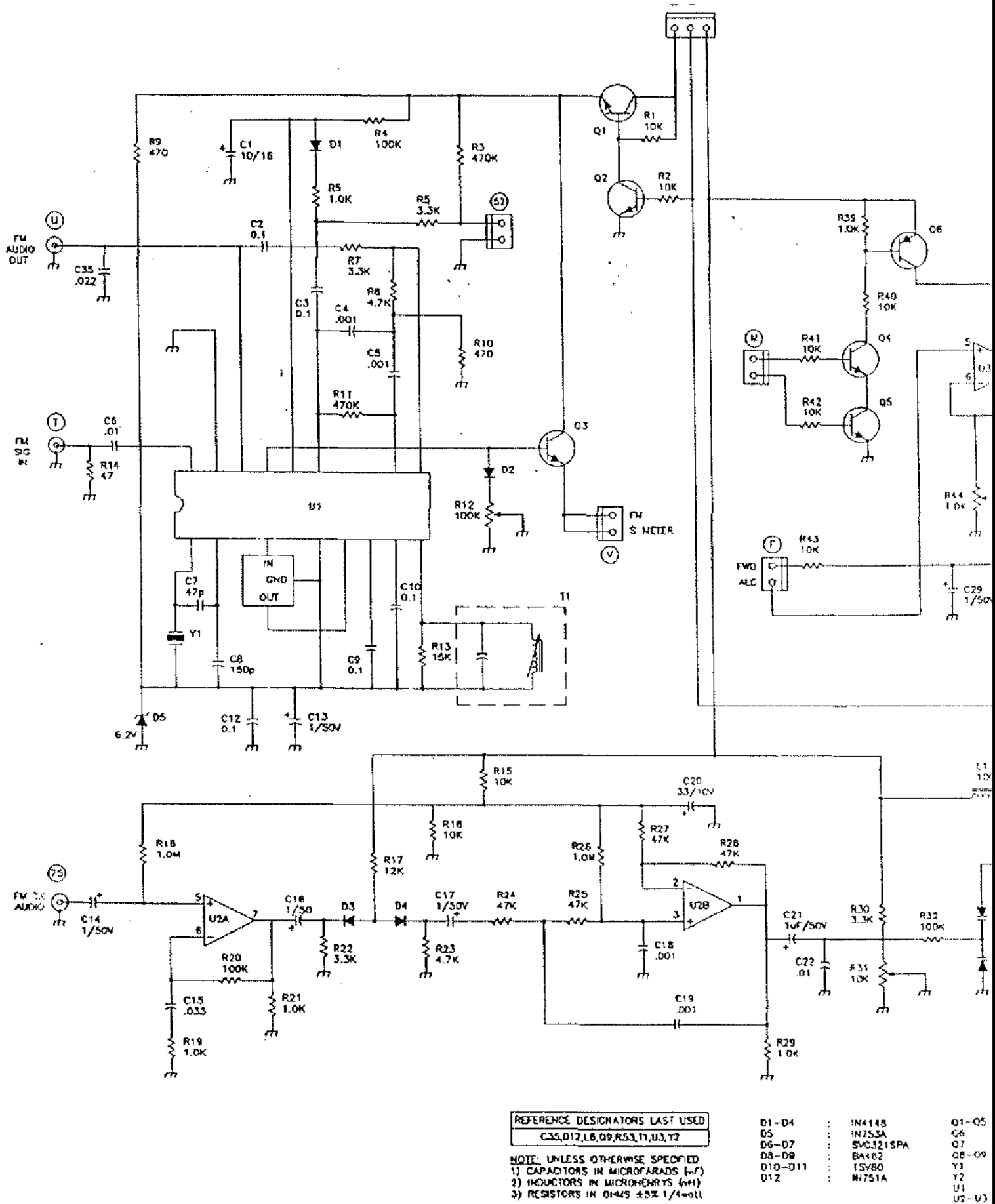
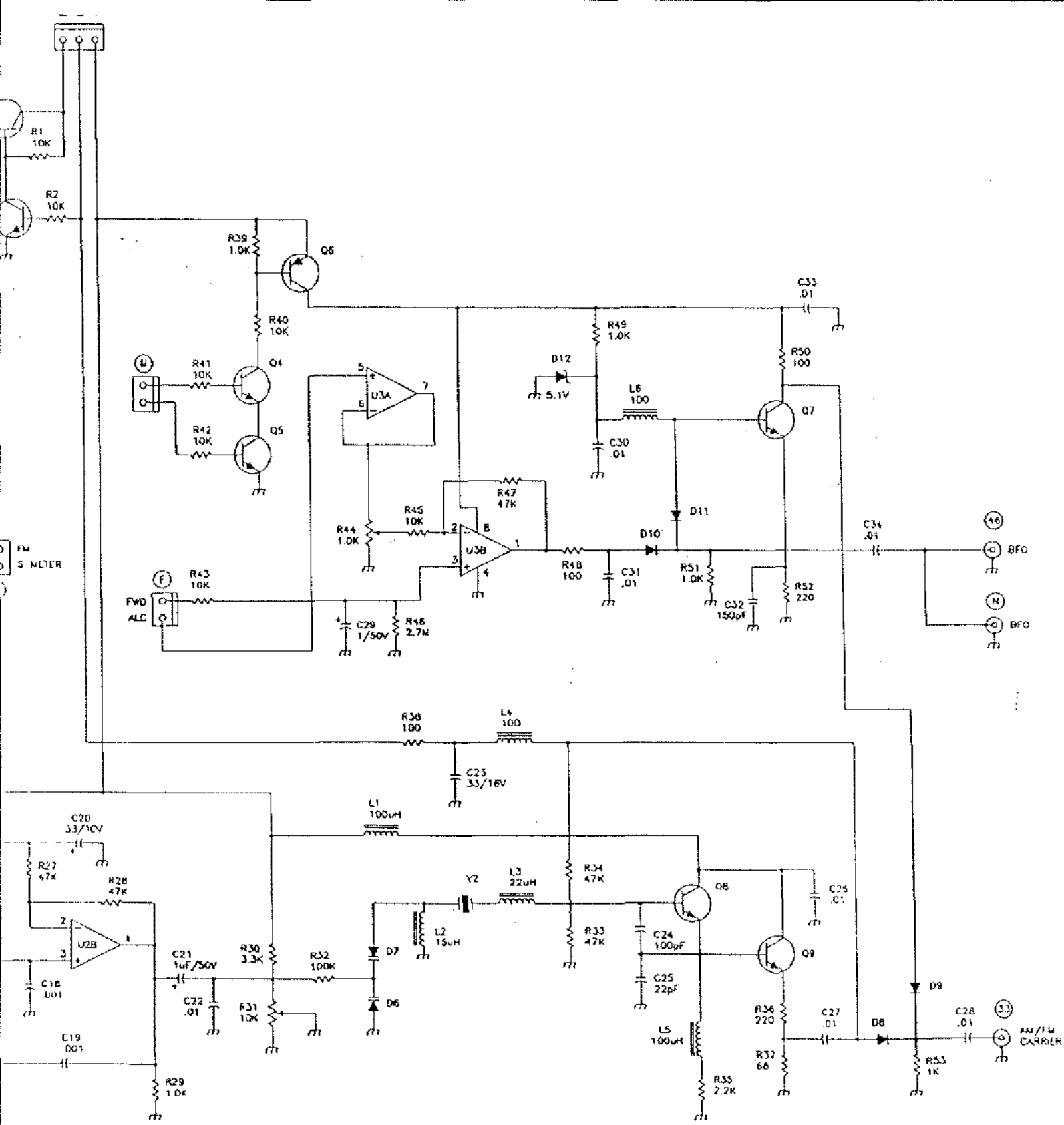

FIGURE 4-38. AM/FM BOARD SCHEMATIC (81)



COMPONENTS LAST USED
R53, U3, Y2

UNLESS OTHERWISE SPECIFIED
RESISTORS IN OHMS (Ω)
CAPACITORS IN PICOFARADS (pF)
MICROFARADS (μF)
MILLIHENRYS (mH)
WATT (W)

01-04	: IN4148	01-05	: MPS6514
05	: IN753A	06	: 2N5087
06-07	: SVC321SPA	07	: MPS3866
08-09	: BA482	08-09	: 2N4124
010-011	: 1SV80	Y1	: 8.545 MHZ X1AL
012	: IN751A	Y2	: 0.0033 MHZ X1AL
		U1	: MC3371P
		U2-U3	: LM358N

4-38. AM/FM BOARD SCHEMATIC (81635)

Part No. 74242
October 1993
Printed in U.S.A.

4-21. PHASE LOCKED LOOP BLOCK DIAGRAM

The phase locked loop subsystem is responsible for generating the variable first local oscillator injection frequency of 70.1-100 MHz in 10 Hz steps, and the fixed second local oscillator signal of 79 MHz. The frequency accuracy of these signals is determined by a crystal controlled 39.5 MHz master oscillator on the PLL reference oscillator board.

The fine resolution steps of 10 Hz for the 1st LO are developed by the minor loop board. In the minor loop, a VCO covering the frequency range of 120-130 MHz is phase locked to a 2 KHz reference obtained by dividing a 3.95 MHz output of the reference oscillator board by 1975. This produces an output of 120-130 MHz with 2 KHz resolution, which is then divided by 200 to produce 0.6-0.65 MHz in 10 Hz steps. This 0.6-0.65 MHz signal is mixed with another 3.95 MHz output from the reference oscillator board to produce the 4.55-4.6 MHz minor loop output with 10 Hz resolution.

The 4.55-4.6 MHz output from the minor loop board is translated again on the reference oscillator board by mixing with the 39.5 MHz master oscillator signal to produce an output to the PLL major loop board of 44.05-44.1 in 10 Hz steps.

The PLL major loop board is a mixing loop in which the difference between a VCO operating in the range of 70.1-100 MHz and the 44.05-44.1 MHz output from the reference oscillator board is phase locked to a 50 KHz reference. The 50 KHz reference is developed by dividing a 3.95 MHz output from the reference oscillator board by 79. Although the major loop step size is 50 KHz as set by the 50 KHz reference, the final major loop output of 70.1-100 MHz moves in 10 Hz steps as determined by the 44.05-44.1 MHz from the minor loop. Four VCOs are used to cover the 70.1-100 MHz range to keep noise and microphonics to acceptable levels.

On the reference oscillator board, the 39.5 MHz master oscillator signal is passed through a filter to form the second LO injection of 79 MHz.

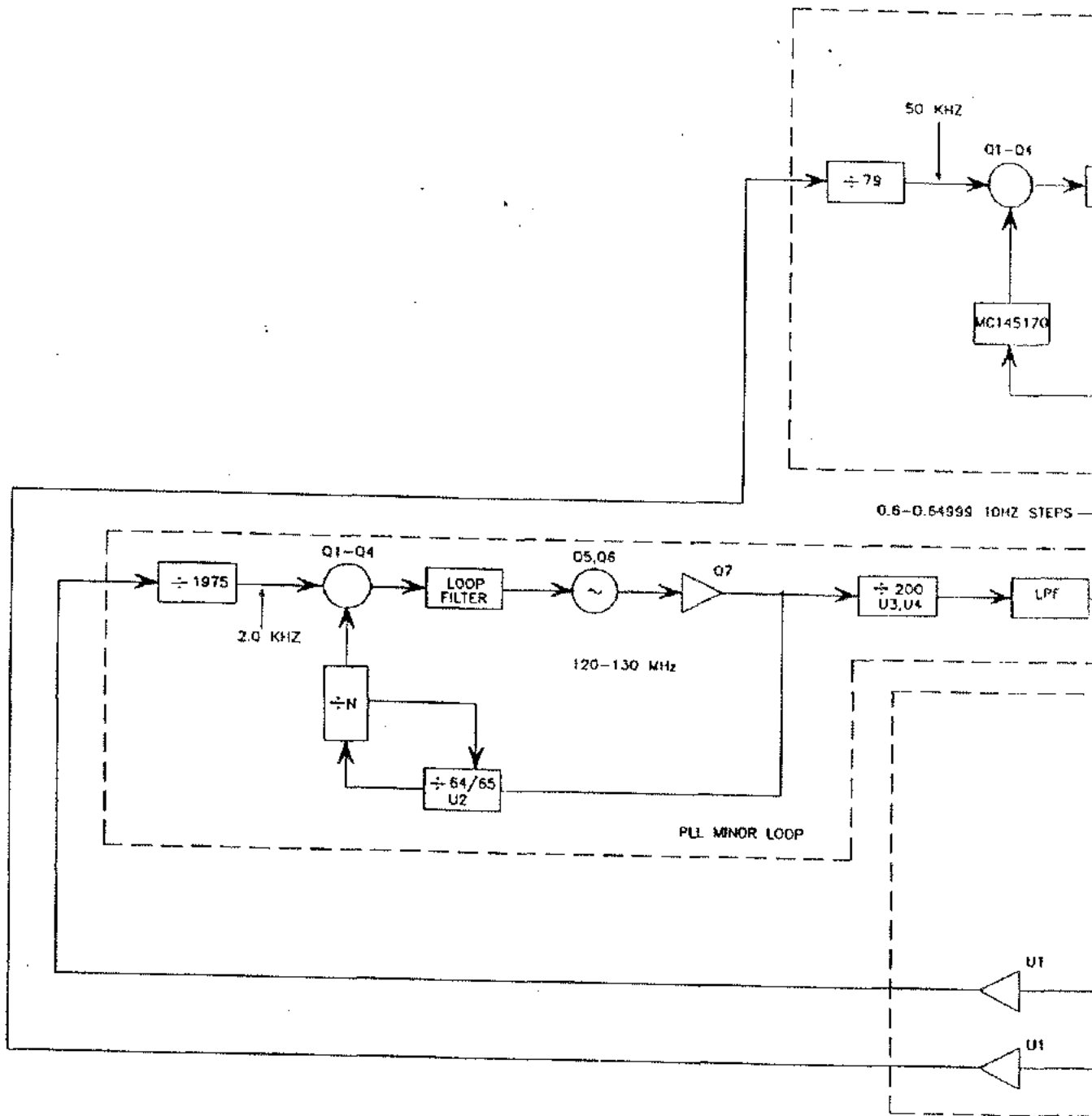
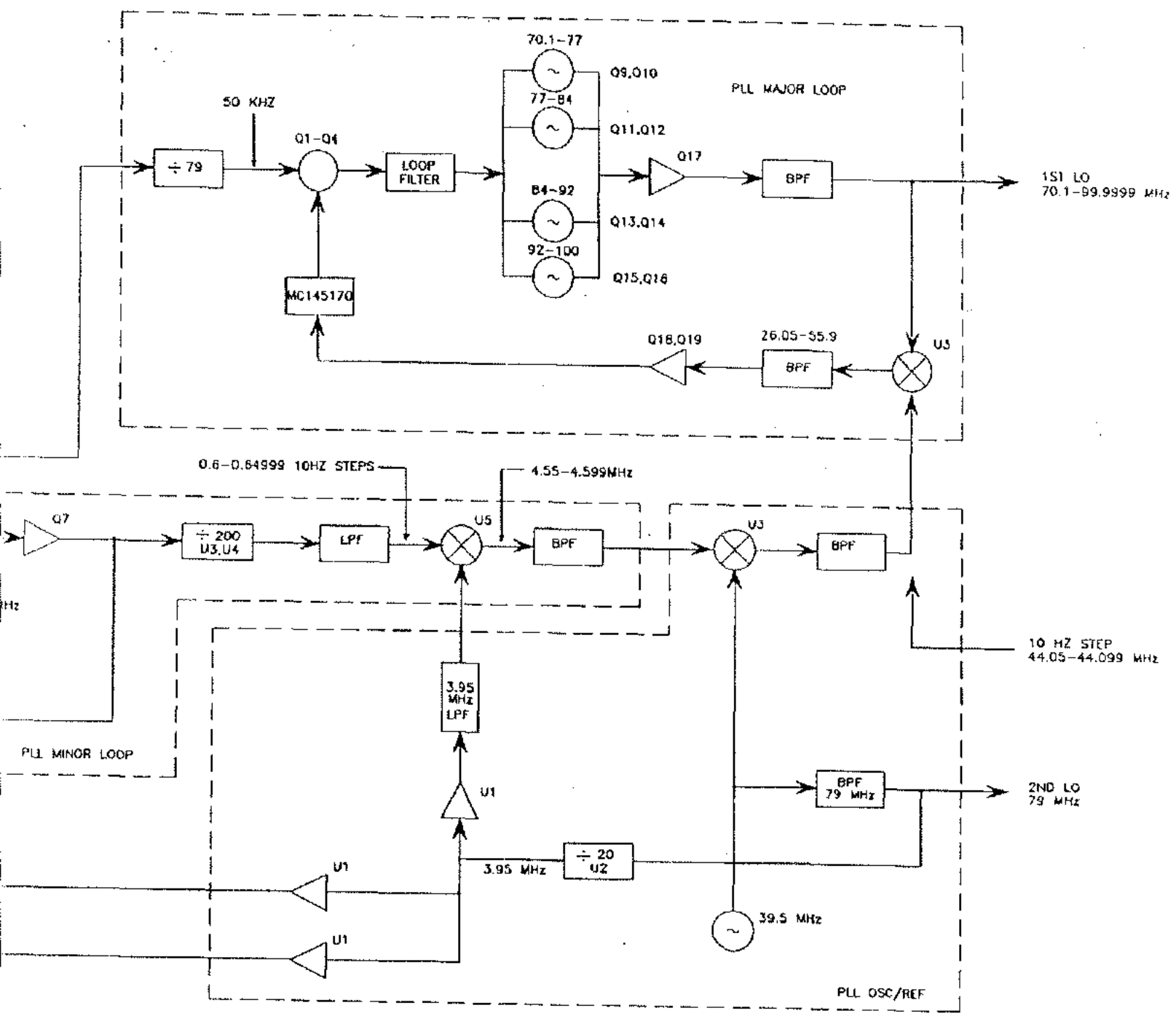

FIGURE 4-39. PHASE LOCKED LOOP BLOCK DIAGRAM



PLL LOCKED LOOP BLOCK DIAGRAM SCHEMATIC

4-22. PLL MAJOR LOOP BOARD (81636)

The PLL major loop board is a mixing loop in which the difference between a VCO operating in the range of 70.1-100 MHz and the 44.05-44.1 MHz minor loop output is phase locked to a 50 KHz reference. Although the major loop step size is 50 KHz as set by the 50 KHz reference, the final major loop output of 70.1-100 MHz moves in 10 Hz steps as determined by the 44.05-44.1 MHz from the minor loop. Four VCOs are used to cover the 70.1-100 MHz range to keep noise and microphonics to acceptable levels. Serial programming from

the logic board (by way of the minor loop board) and VCO select lines from the control filter board are received on connectors 83 and 90 respectively. Connector 82 carries the +13.5v and the +10.4v necessary to power the major loop circuits. The 3.95 MHz reference signal and the 44.05-44.1 MHz minor loop signal come from the reference oscillator board on connectors 88 and 89 respectively. The 70.1-100 MHz 1st LO signal is output to the first mixer board on connector 26.

PLL circuit U1 performs the functions of reference divider, programmable counter, and phase detector. The reference divider is programmed by the microprocessor to a fixed divide ratio of 79 which, assuming 3.95 MHz input from the reference oscillator board at connector 88, results in a 50 KHz reference to the phase detector. The programmable counter is programmed to a number based on the

operating frequency which results in dividing the mixer output from Q19 down to 50 KHz for the other phase detector input. Based on the phase and frequency difference between the divided down signals from reference connector 88 and the mixer output from Q19, the phase detector in U1 drives charge pump circuit Q1-Q4 to add or subtract charge from the loop filter capacitors C9-C11. A low voltage on one of four VCO select lines at connector 90 activates a VCO which operates on a frequency determined by the loop filter voltage across tuning diodes D10-D13. The selected VCO forward biases one of the diode switches D6-D9 to drive buffer amplifier Q17. The output of Q17 in the frequency range of 70.1-100 MHz is filtered by bandpass filter C31-C35, L20-L24 and becomes the 1st LO injection to the first mixer board at connector 26. A sample of this output is mixed with the minor loop output at connector 89 by double balanced mixer U2 and the difference frequency output is selected by bandpass filter C42-C43, C45-C46, C52, L7 and L9. This difference frequency of 26.05-55.90 MHz passes through broadband amplifiers Q18 and Q19 to drive U1, thus closing the loop.

13.5 Volt power from minor loop connector 82 is reduced to 5 Volts by R7 and D1 to supply U1. A voltage regulator on the reference oscillator board supplies 10.4 volts regulated via minor loop connector 81 and 82 for the remaining circuitry on this board.

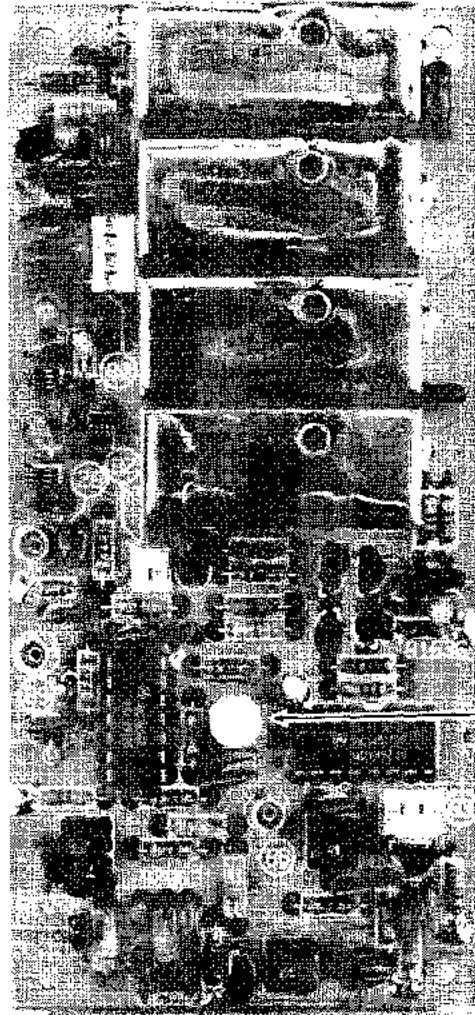

VCO A

VCO B

VCO C

VCO D

R42

FIGURE 4-40. PLL MAJOR LOOP BOARD COMPONENT LAYOUT (81636)

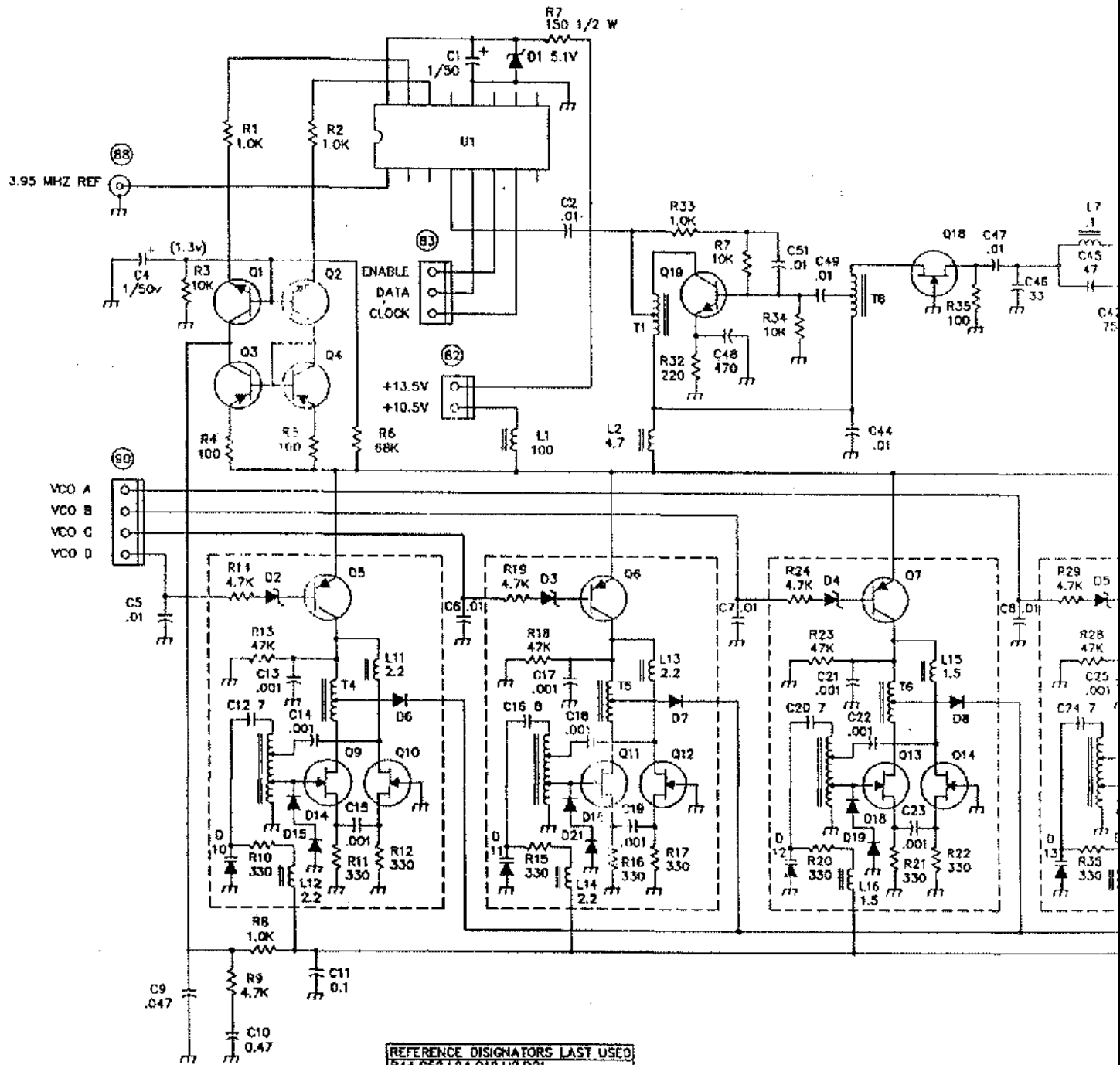

REFERENCE DESIGNATORS LAST USED
 R44, C52, L24, Q19, U2, D21

NOTE: UNLESS OTHERWISE SPECIFIED
 1) CAPACITORS IN PICO FARADS (PF)
 2) INDUCTORS IN MICROHENRYS (UH)
 3) RESISTORS IN OHMS ±5% 1/4W

U1 : MC145170P	D2-D5 : 1N754A	Q1, Q2
U2 : MC1496P	D6-D9 : BA182	Q3-Q8
D1 : 1N751A	D10-D13 : KV3902	Q9-Q16
	D14-D21 : 1N4148	Q19

FIGURE 4-41. PLL MAJOR LOOP BOARD SCH

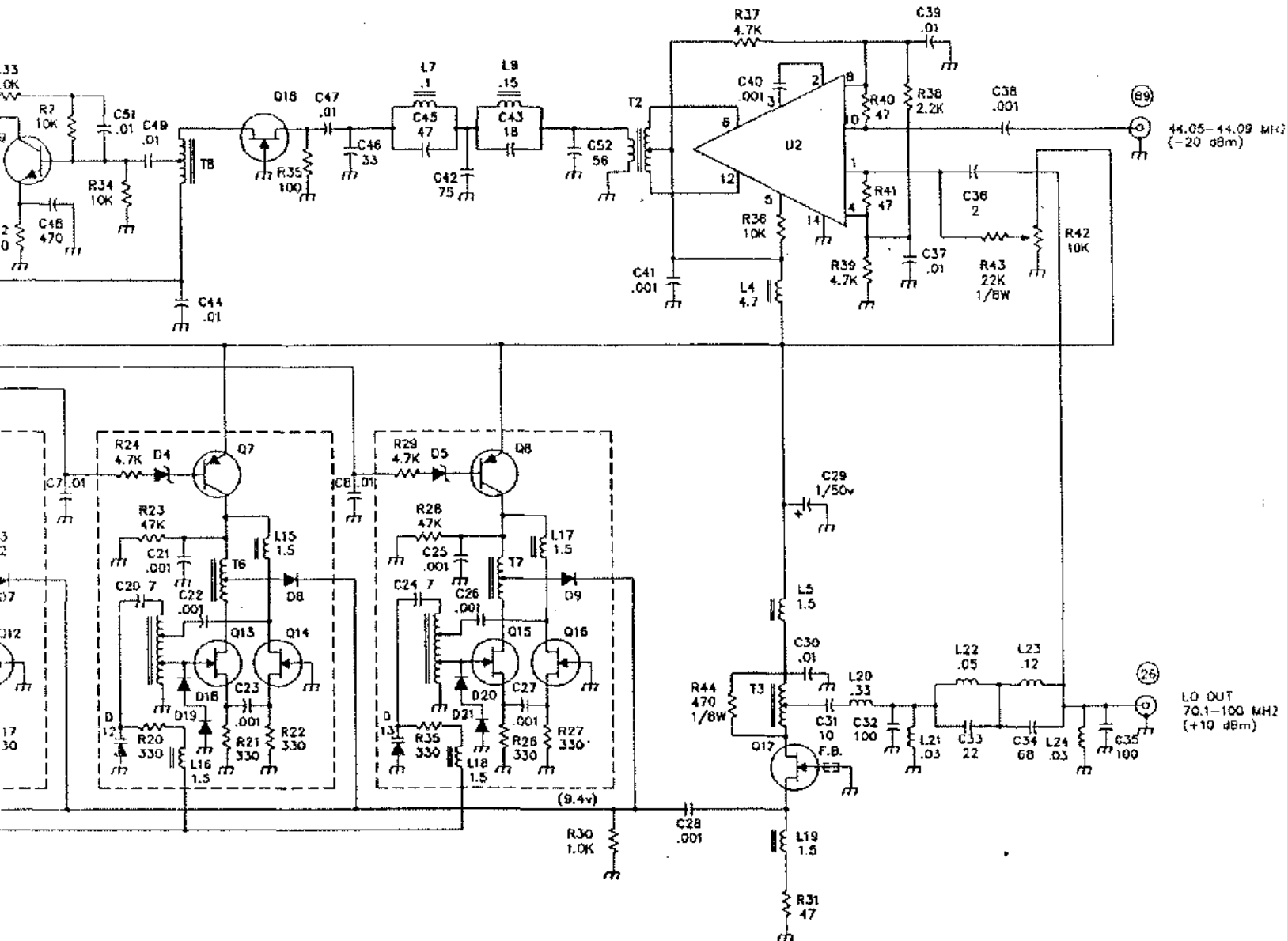

- | | | |
|----------------|------------------|------------------|
| U1 : MC145170P | D2-D5 : 1N754A | Q1, Q2 : MPS6514 |
| U2 : MC1495P | D6-D9 : BA482 | Q3-Q8 : 2N5087 |
| O1 : 1N751A | D10-D13 : KV3902 | Q9-Q18 : J510 |
| | D14-D21 : 1N4148 | Q19 : MPS5179 |

4-41. PLL MAJOR LOOP BOARD SCHEMATIC (81636)

4-23. PLL MINOR LOOP BOARD (81637)

The minor loop develops the fine resolution 10 Hz steps of the synthesizer by dividing the output of a 2 KHz resolution phase locked loop by 200. The 2 KHz minor loop VCO operates in the frequency range of 120-130 MHz resulting in a divided down output range of 600-650 KHz. This 50 KHz range fills in the gaps between the 50 KHz steps of the major loop providing an overall resolution of 10 Hz for the synthesizer. The 600-650 KHz signal is translated upward twice by mixing first with 3.95 MHz from connector 86 and then (via connector 87) with 39.5 MHz on the reference oscillator board to become the 44.05-44.1 MHz minor loop input to major loop board connector 89.

PLL circuit U1 performs the functions of reference divider, programmable counter, and phase detector. The reference divider is programmed by the microprocessor to a fixed divide ratio of 1975 which, assuming 3.95 MHz input from the reference oscillator board at connector 85, results in a 2 KHz reference to the phase detector. The programmable counter is programmed to a number based on the operating frequency which, in conjunction with prescaler U2, results in dividing the VCO output from Q7 down to 2 KHz for the other phase detector input. U2 is a dual modulus prescaler which extends the frequency range and resolution of the programmable counter in U1. Based

on the phase and frequency difference between the divided down signal from reference connector 85 and VCO output from Q7, the phase detector in U1 drives charge pump circuit Q1-Q4 to add or subtract charge from loop filter capacitors C1 and C2, determining the voltage across tuning diode D1 and the operating frequency of the VCO, Q5-Q6. VCO buffer Q7 drives two prescalers through C12 and L6: U2, which closes the phase locked loop, and the U3-U4 combination which performs a fixed division by 200.

The output of U4, after lowpass filtering by C21-24, L8-9, has a step size of 10 Hz, but at 600-650 KHz its frequency is too low to be easily mixed with the major loop output of 70.1-100 MHz. It is therefore translated up in frequency by mixing with 3.95 MHz from the reference oscillator board connector 86 in diode mixer D5-D8. The sum frequency output of the diode mixer at 4.55-4.6 MHz is selected by bandpass filter C13-19, L4-5 and sent to the reference oscillator board via connector 87 for further translation to 44.05-44.1 MHz. This signal, still with 10 Hz resolution, is finally routed to the minor loop input of the major loop board at connector 89.

13.5 Volts from connector 81 is reduced to 5 Volts power for U1-U4 by shunt regulator R19 and D2. A regulator on the reference oscillator board provides 10.5 Volts power to the remaining circuitry and to the major loop board via connectors 81 and 82.

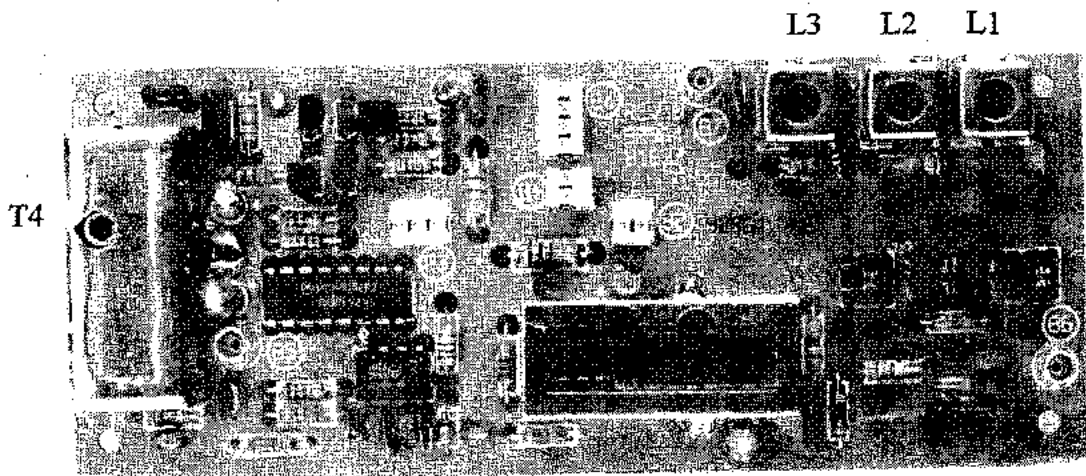
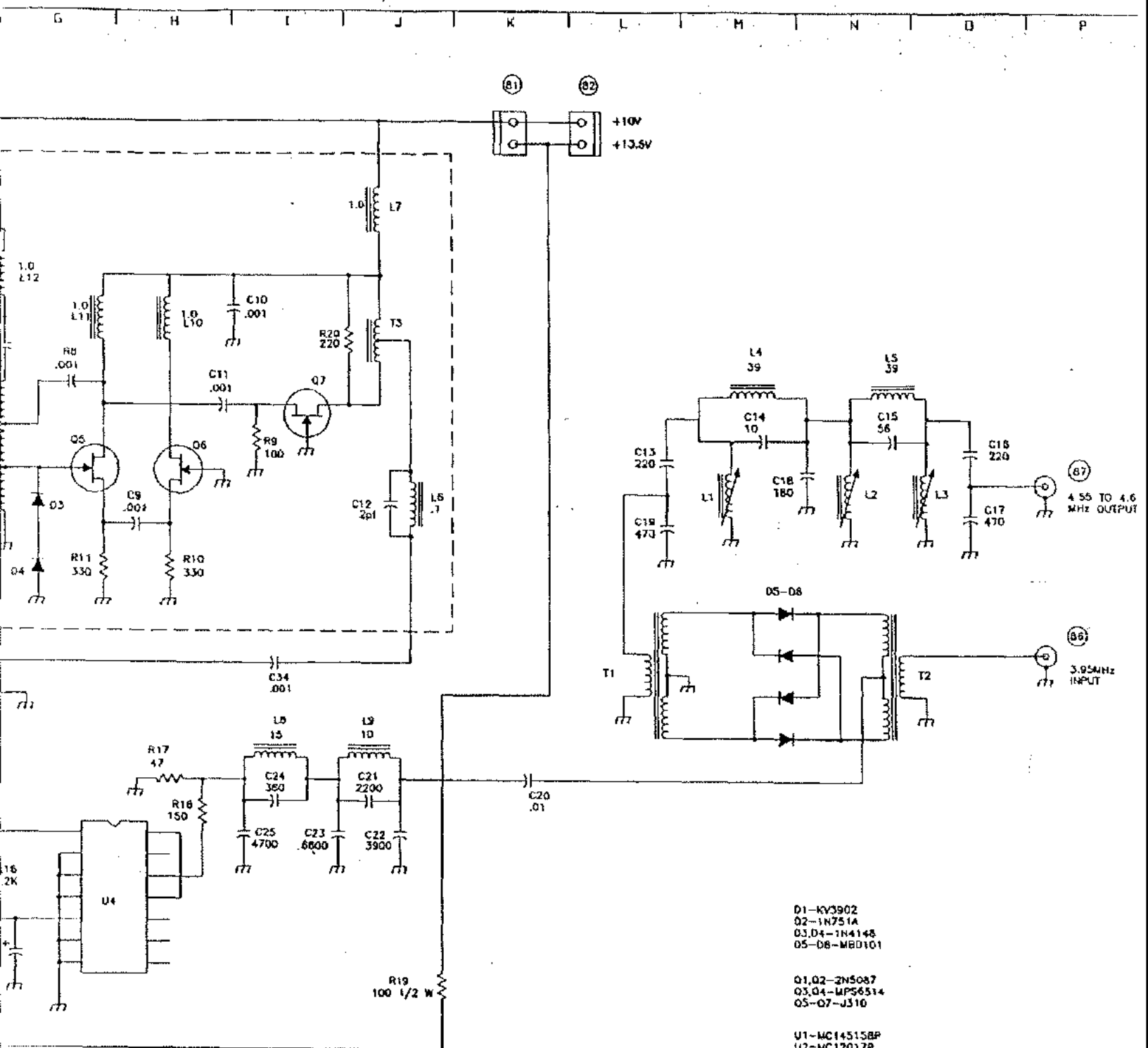

FIGURE 4-42. PLL MINOR LOOP BOARD COMPONENT LAYOUT (81637)



- D1-KV3902
- D2-1N751A
- D3,D4-1N4148
- D5-D8-MBD101
- Q1,Q2-2N5087
- Q3,Q4-MPS6514
- Q5-Q7-J310
- U1-MC14515BP
- U2-MC12017P
- U3-CA3232E
- U4-74LS90

L MINOR LOOP BOARD SCHEMATIC (81637)

ORION II IS ALL ABOUT... LISTENING



**While you listen to signals, we listen to you...
and your ideas for an even better ORION.**

Reviewers raved about the original ORION's stellar receiver performance. Always reaching for that competitive edge, you asked for even more. The new ORION II adds:

- Bright TFT color display with CCFL backlighting
- New roofing filter suite with the narrow filters now located in the same bank with all the rest. Provides a subtle improvement in dynamic range
 - Faster sweep scope with finer resolution
 - Programmable stereo line level outputs
 - The most popular 8-pin mic connector

What hasn't changed? TEN-TEC's legendary customer service—we're only a phone call or email away when you want us.

Call us today at **(800) 833-7373** to place your order. ORION II is \$3995*; \$4295* with automatic antenna tuner. *Ask about our 4-month finance plan.*

800-833-7373
www.tentec.com



1185 Dolly Parton Parkway • Sevierville, TN 37862
Sales Dept: 800-833-7373 • Sales Dept: sales@tentec.com • Service Dept: service@tentec.com
Monday - Friday 8:00 - 5:30 EST • We accept VISA, Mastercard, Discover, and American Express
Office: (865) 453-7172 • FAX: (865) 428-4483 • Repair Dept.: (865) 428-0364 (8 - 5 EST)
*Shipping is additional. TN residents add 9.5% TN sales tax.

ORION II IS ALL ABOUT... LISTENING



**While you listen to signals, we listen to you...
and your ideas for an even better ORION.**

Reviewers raved about the original ORION's stellar receiver performance. Always reaching for that competitive edge, you asked for even more. The new ORION II adds:

- Bright TFT color display with CCFL backlighting
- New roofing filter suite with the narrow filters now located in the same bank with all the rest. Provides a subtle improvement in dynamic range
 - Faster sweep scope with finer resolution
 - Programmable stereo line level outputs
 - The most popular 8-pin mic connector

What hasn't changed? TEN-TEC's legendary customer service—we're only a phone call or email away when you want us.

Call us today at **(800) 833-7373** to place your order. ORION II is \$3995*; \$4295* with automatic antenna tuner. *Ask about our 4-month finance plan.*

800-833-7373
www.tentec.com



1185 Dolly Parton Parkway • Sevierville, TN 37862
Sales Dept: 800-833-7373 • Sales Dept: sales@tentec.com • Service Dept: service@tentec.com
Monday - Friday 8:00 - 5:30 EST • We accept VISA, Mastercard, Discover, and American Express
Office: (865) 453-7172 • FAX: (865) 428-4483 • Repair Dept.: (865) 428-0364 (8 - 5 EST)
*Shipping is additional. TN residents add 9.5% TN sales tax.

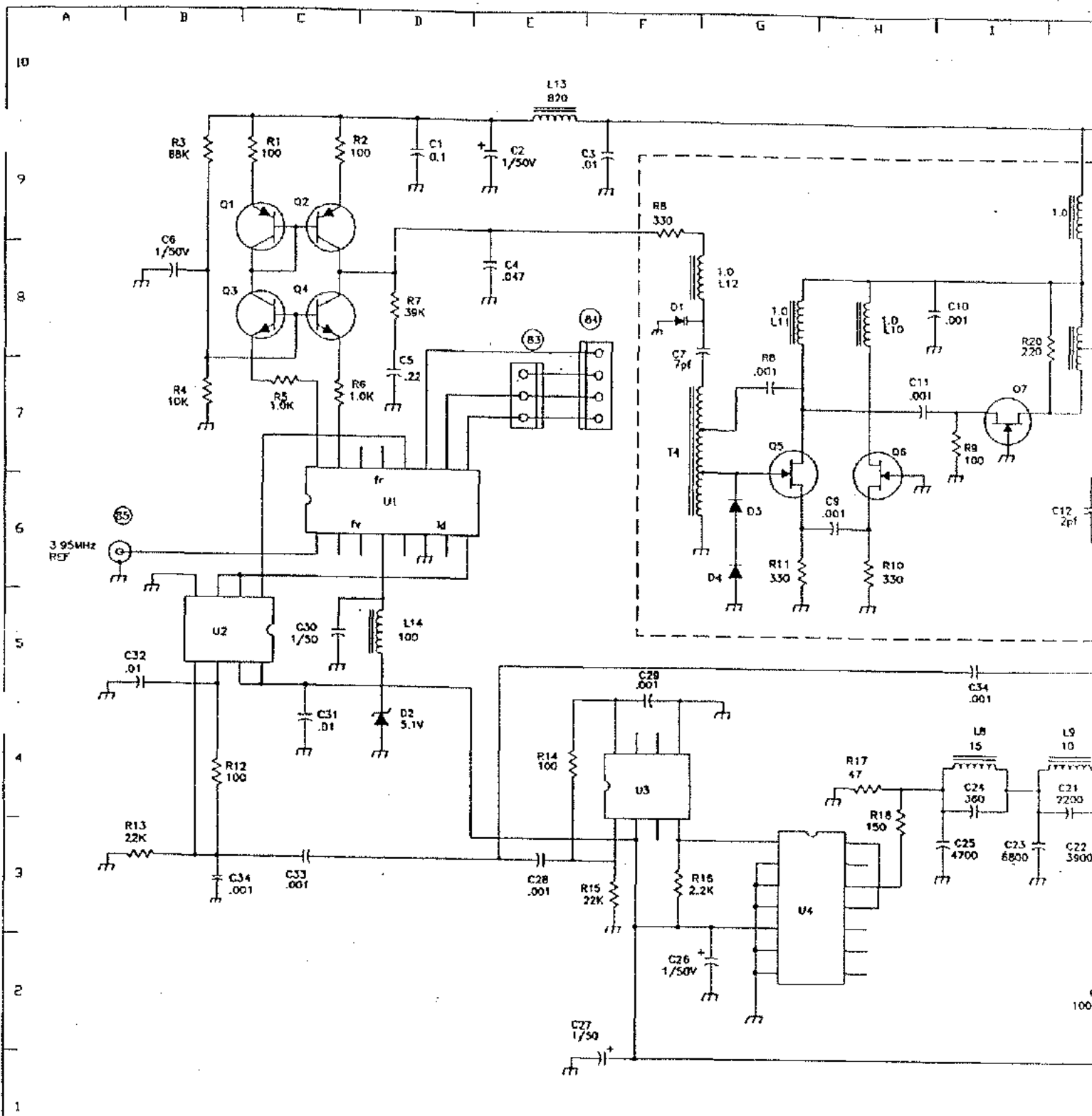

FIGURE 4-43. PLL MINOR LOOP BOARD SCHEMATIC

4-24. REFERENCE OSCILLATOR (81638)

This board contains the 39.5 MHz master oscillator that determines the accuracy of the 1st and 2nd local oscillator injection frequencies. The 2nd harmonic of the 39.5 MHz output is filtered to set the 2nd local oscillator at 79 MHz. The 79 MHz 2nd local oscillator output is divided by 20 to form a 3.95 MHz reference signal which is used by the PLL boards to develop the 1st LO. This board also contains a mixer and filter circuit which converts the PLL minor loop signal of 4.55-4.6 MHz up to 44.05-44.10 MHz for use by the PLL major loop.

The cascoded pair of Q2 and Q3, along with the third overtone crystal Y1, form a crystal controlled Colpitts oscillator stage. Trimmer C35 is provided for setting the oscillator output frequency to exactly 39.5 MHz. The tuned circuit off the collector of Q2 sets the 79 MHz 2nd local oscillator output. L1-L3 and C3-C8 form a triple-tuned band pass filter which cleans up the 79 MHz signal before it is sent to the 2nd mixer via connector 27.

C1 couples some of the 79 MHz 2nd local oscillator output into frequency divider U1. U1 divides this 39.5 MHz input by 20 to form a 3.95 MHz reference signal which is distributed to the PLL boards by buffers U1 via connectors 85, 86 and 88.

T3 off the emitter of Q3 feeds the 39.5 MHz signal to diode mixer D2-D5 via FET buffer stage Q4. The diode mixer mixes its 39.5 MHz input with the PLL minor loop input of 4.55-4.6 MHz from connector 87 to produce an output of 44.05-44.1 MHz. This signal is filtered by the triple-tuned network of L8-L10 and C24-C28 before being sent to the PLL major loop via connector 89.

13.5 Vdc power from connector 3 is regulated to 10.4 Volts for the voltage sensitive oscillator and balanced mixer stages by U3 and Q1. Dropping resistor R4 and Zener Diode D1 provide 5 volts power to U1 and U2.

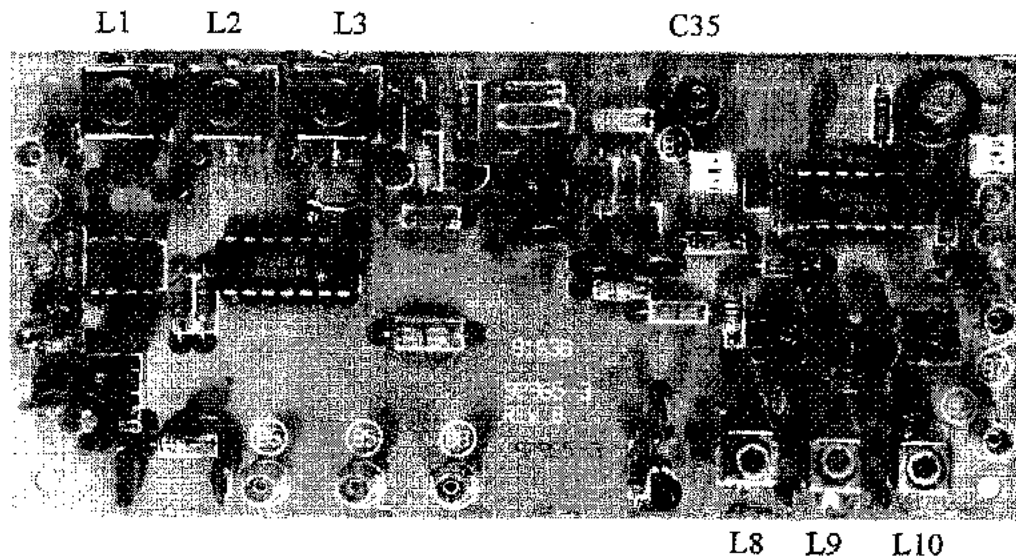

FIGURE 4-44. REFERENCE OSCILLATOR COMPONENT LAYOUT (81638)

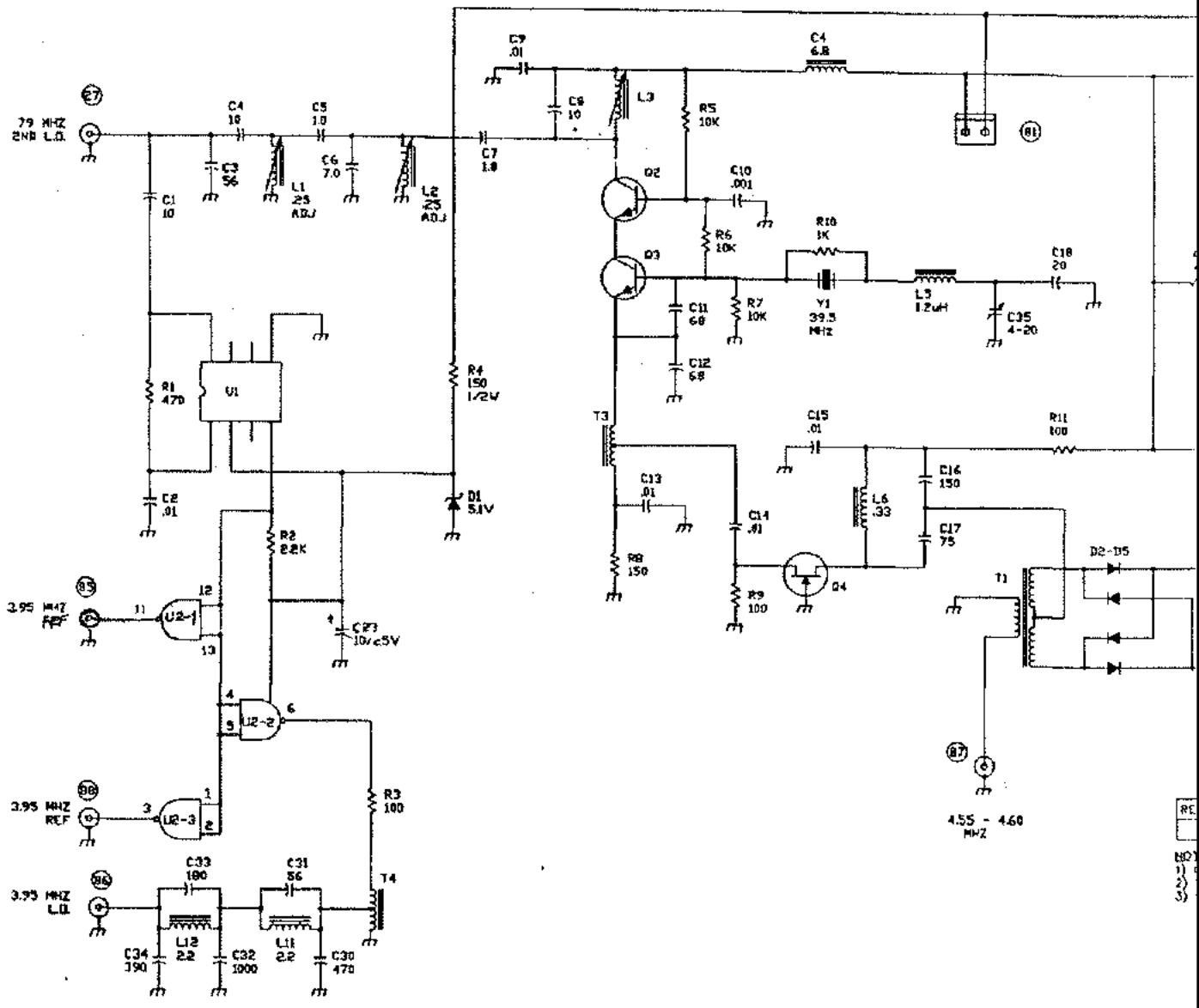
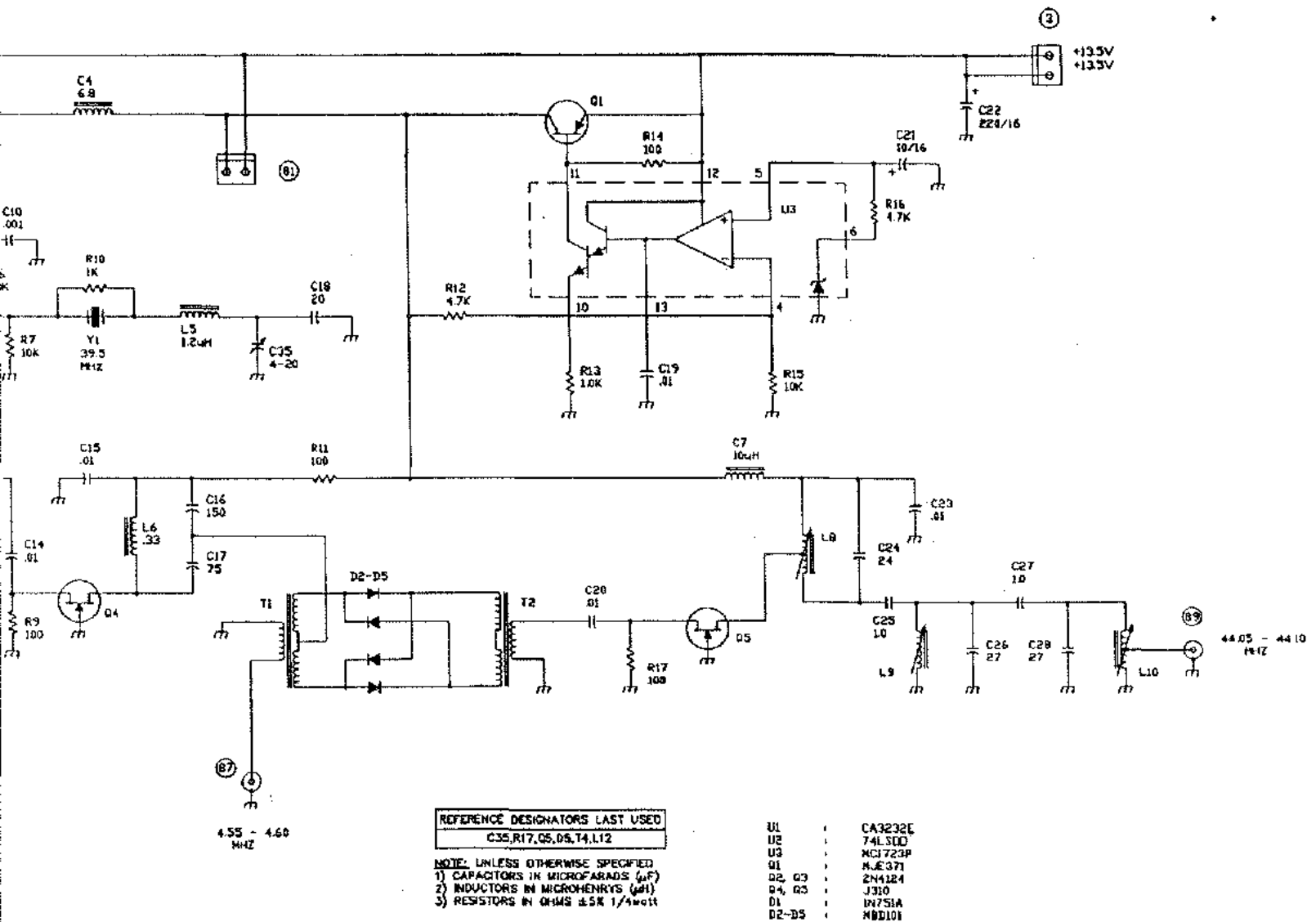

FIGURE 4-45. REFERENCE OSCILLATOR SC



E 4-45. REFERENCE OSCILLATOR SCHEMATIC (81638)

4-25. CONTROL BOARD (81639)

This board contains diode and transistor logic circuitry to develop control voltages based on inputs from the logic board, rear panel control jacks, or front panel switches, that determine the mode of operation (SSB, CW, transmit, receive, etc.) of the various circuits in the transceiver. It also contains the adjustable CW wave shaping circuit that sets the rise and fall times of the transmitted CW envelope, and the hold-in adjustment for the auxiliary T/R relay.

The main mode information enters at connector 59, while "T" voltage (indicating transmit mode) enters at connector 61. Q1-Q4 along with D1-D6 are used to create the necessary signals for the TX Audio Board via connector 60.

A request to key the transmitter is generated by grounding the PTT (rear panel or microphone/VOX via switch board connector 65) or CW KEY lines, or a TUNE output from the logic board, which forward biases Q12 or D7, sending a high level to the microprocessor via connector 66, and via D15 to the mute pin of IF/AF connector 45. The microprocessor buffers the transmit request and drives Q13, pulling the center pin of the rear panel TX OUT connector to ground. Normally the TX OUT connector is jumpered to the TX ENable connector and the low level from Q13 is passed directly to keying waveshape circuit Q6-Q9. An external keying interlock loop may be substituted for the jumper between TX OUT and TX ENable. Such an interlock may be used to prevent

"hot switching" of a QSK linear amplifier, for example.

The keying waveshape circuit Q6-Q9 is an adjustable integrator that slows down the rise and fall times of the keying voltage "TD" which is sent to the T/R generator on the low level amplifier board via connector 61, and to the balanced modulator on the TX audio board via connector 60. CW waveshape adjustment R29 sets the keying rise and fall times in the range of 1-5 mS. This waveshaping has little effect on the T/R generator since its switching threshold is below 1 Volt. The balanced modulator, however, has a more gradual increase in gain as "TD" goes high, thus transferring the slowed rise and fall times to the transmitted keying waveform.

The buffered transmit request signal from the microprocessor at connector 66 also drives control relay K1 via D12 and Q14 to provide a ground at the center pin of the rear panel RELAY OUT connector during transmit. In CW mode, Q11 connects C8 into the circuit to hold Q14 and K1 on between dits. This hold-in time is adjusted by the board mounted DELAY ADJUST pot R10.

The CW key line is connected to connector 63 through R12 and Q10. This circuit provides a CW keying signal to the Sidetone Oscillator Board via connector 63.

Cables 61/62, 40/39, 10/9, 21/20, 36/35, 45/44, and 5 distribute T, R, +REG, and +13.5 Volts to several boards. Wires in these cables are color coded as follows: T - blue, R - yellow, +REG - orange, +13.5 - red.

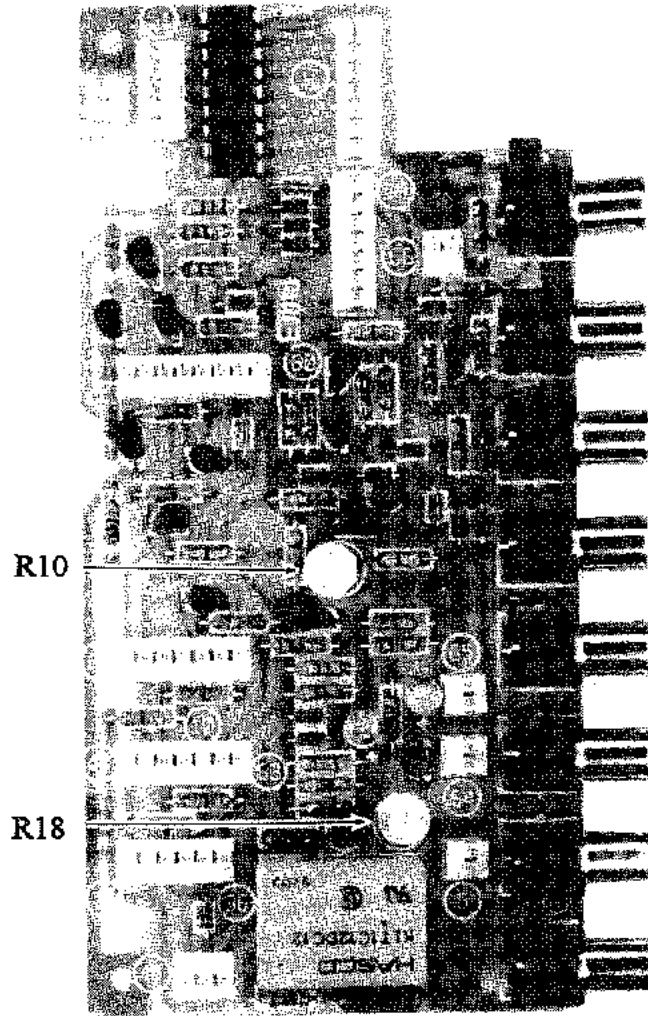
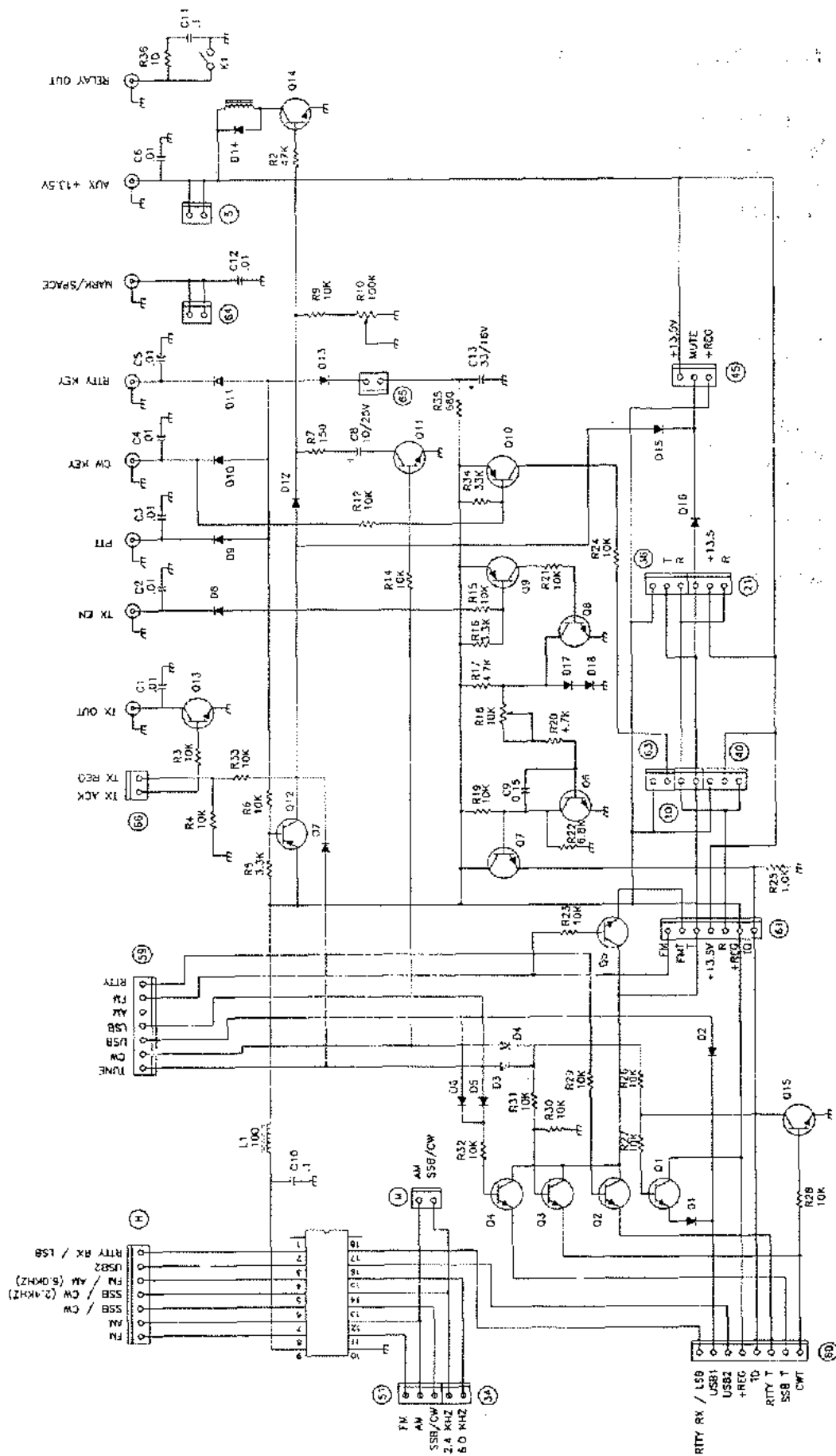

FIGURE 4-46. CONTROL BOARD COMPONENT LAYOUT (81639)



- 81-016 IN6148
- U1 UDN2985A
- U1-C8 MP56514
- Q1, Q13 MP56514
- Q9, Q10, Q12 2N3637
- Q14 MP5614

REFERENCE DESIGNATORS LAST USED:
 C13R, Q13, Q14, K1
 NOTE: UNLESS OTHERWISE SPECIFIED:
 1) CAPACITORS IN MICROFARADS (μF)
 2) INDUCTORS IN MILLIHENRYS (mH)
 3) RESISTORS IN OHMS x 5K 1/1000

FIGURE 4-47. CONTROL BOARD SCHEMATIC (81639)

4-26. SIDETONE BOARD (81689)

The sidetone board is mounted on the left rear panel with four controls accessible from the rear. The controls are user adjustable CW sidetone PITCH and LEVEL, transmit audio MONITOR level, and keypad BEEP/VOICE synthesizer level. The CIV serial data mini jack is also located on this assembly.

The sidetone is pulsed high from connector 63 from the control board. This turns on the MPS 6514 transistor and clamps C2 to ground. This enables the audio oscillator located on this board. The frequency of oscillation is determined by the pitch control while the output level is determined by the level control.

MONITOR control R12 receives a sample of the transmit audio signal from the TX Audio/BFO board on connector 72. The BEEP/VOICE control R14 receives keyboard beep and optional voice synthesizer signal from the digital board via connector 80. The outputs from the three level controls are summed into an audio amplifier on the IF/AF board via connector 57.

Anti-vox and speaker connections jumper through this board from the external speaker jack at connector 76 to the TX Audio/BFO board via connector 72 and the internal speaker via connector 77.

Serial data is also present through the CIV 1/8" mini jack. The serial information travels to the sidetone board via connector W from the RS232 interface board.

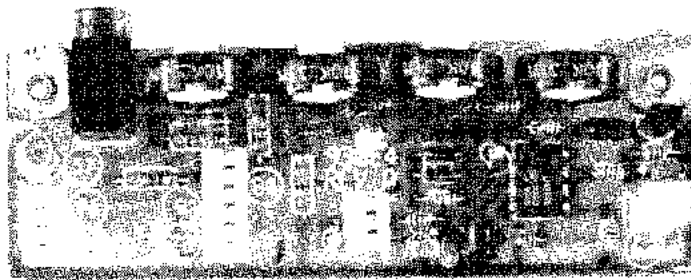

FIGURE 4-48. SIDETONE BOARD COMPONENT LAYOUT (81689)

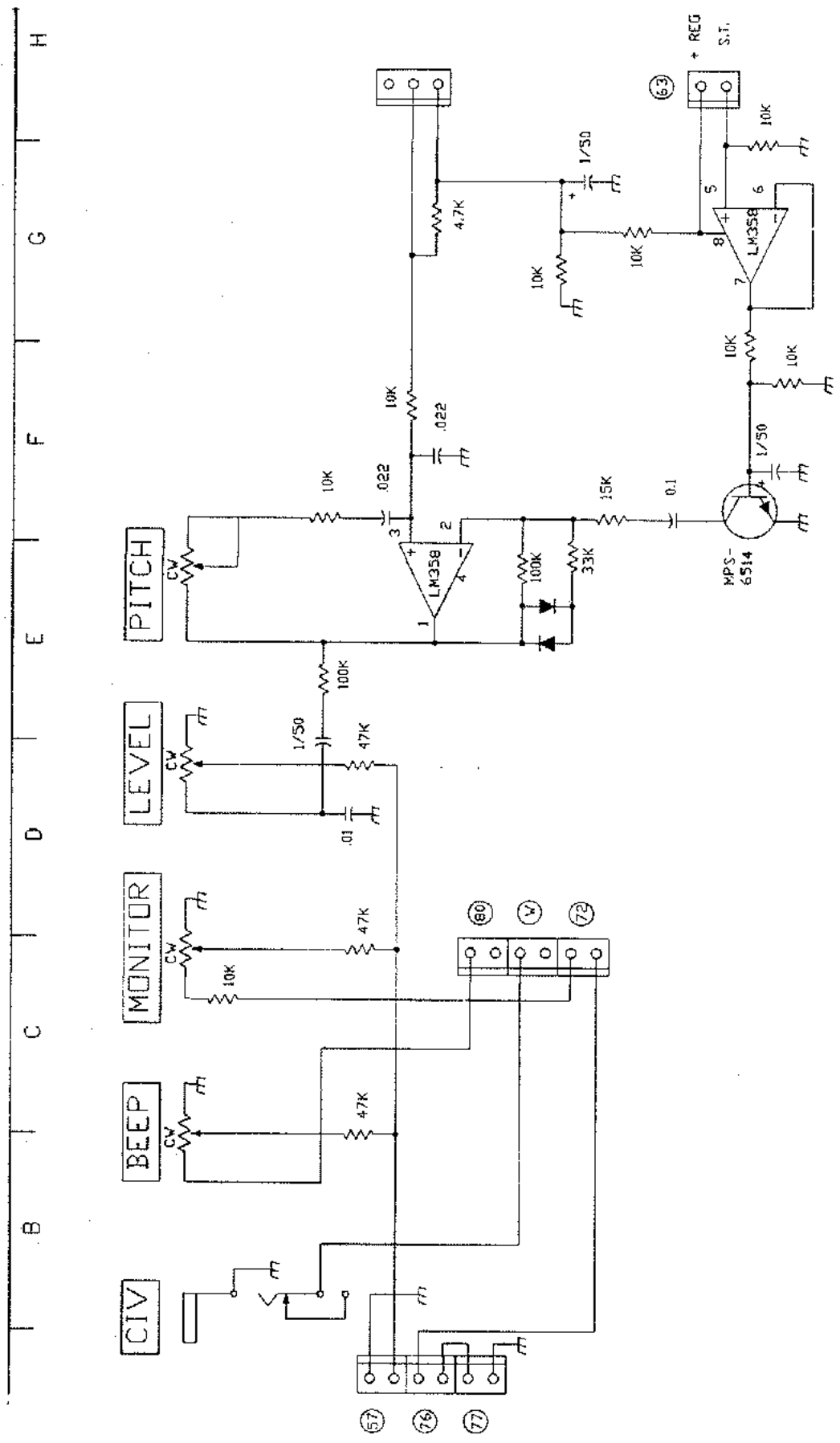

FIGURE 4-49. SIDETONE BOARD SCHEMATIC (81689)

4-27. LOWER POT BOARD (81690)

This board contains two dual concentric controls, a latching pushbutton switch, and two LED indicators. The board mounts on the left front panel at the control positions of MIC/RF PWR, RF gain/SQUELch, ALC indicator, and the PROCessor on/off switch and indicator.

When PROCessor on/off switch S1 is in the "on" position, "+REG" voltage is applied to the anode of LED D1 and through connector 70, to a diode on the transmit audio board which routes processed audio to MIC gain control R1 via cable 71. R1 sets the level of the signal returning on cable 71 to the balanced modulator. When S1 is in the "off" position, indicator D1 is

extinguished, and unprocessed transmit audio is routed through R1 to the balanced modulator.

Through connector 29 to the 2nd mixer board, RF PWR control R2 forms a voltage divider which sets the ALC threshold. ALC action develops a current through connector 28 which illuminates ALC indicator D2.

Through connector 50 to the IF/AF board, the RF gain control R3 forms a voltage divider which determines the AGC resting voltage.

Connector 52 connects to the AM/FM board and provides the squelch line for FM. R4 forms a voltage divider which determines the squelch threshold.



FIGURE 4-50. LOWER POT BOARD COMPONENT LAYOUT (81690)

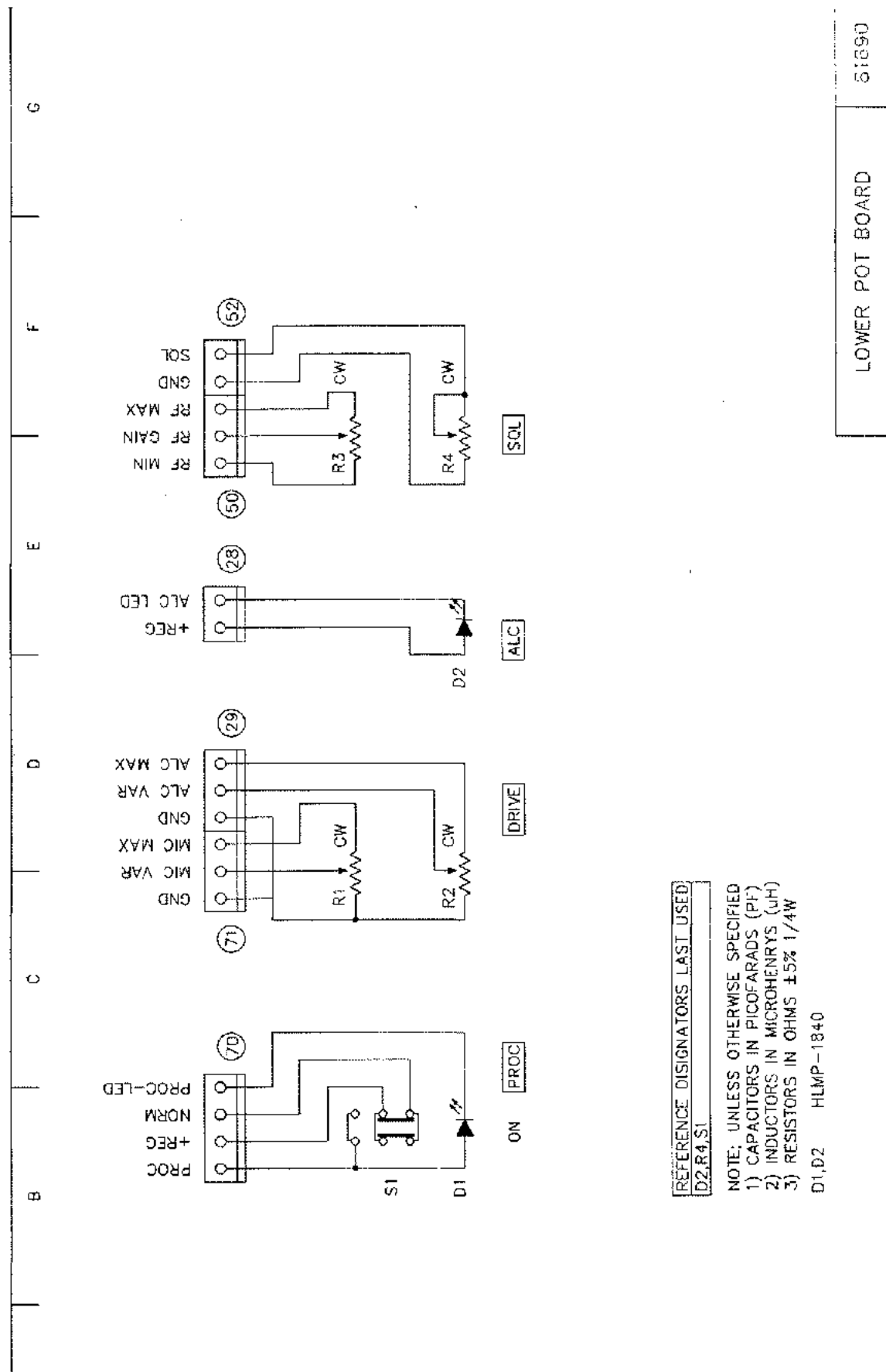

REFERENCE DESIGNATORS LAST USED:
 D2,R4,S1
 NOTE: UNLESS OTHERWISE SPECIFIED
 1) CAPACITORS IN PICOFARADS (PF)
 2) INDUCTORS IN MICROHENRYS (UH)
 3) RESISTORS IN OHMS ±5% 1/4W
 D1,D2 HLMP-1840

FIGURE 4-51. 4-LOWER POT BOARD SCHEMATIC (81690)

4-28. KEYPAD BOARD (81693)

The keypad board contains an array of 44 key switches, 18 LED indicators, a rotary shaft encoder and encoder buffer. The circuit board is mounted to the rear of the front panel keypad bezel and is connected to the digital board through six connectors which are accessible through the sub panel at the rear of the fold down front panel assembly.

The keypad switches are arranged electrically in an array of eleven columns and four rows. The columns are pulled high through connectors 94 and 97, and the rows are pulled low through connector 91.

The microprocessor detects a key closure

by watching for a high on any one of the four rows. The location of the closure is determined by then pulling each column low. When the row that was high goes low, the intersection of row and column is determined and the key closure is known.

The digital board drives the indicator LEDs through connector 92,95,99 and A. The diodes are illuminated by positive voltage drive and all diode cathodes return to ground through connector 95.

Output pulses from the shaft encoder are buffered and inverted by U1 and output to the digital board on connector 93. Connector 93 also supplies 5 Volt power to the encoder.

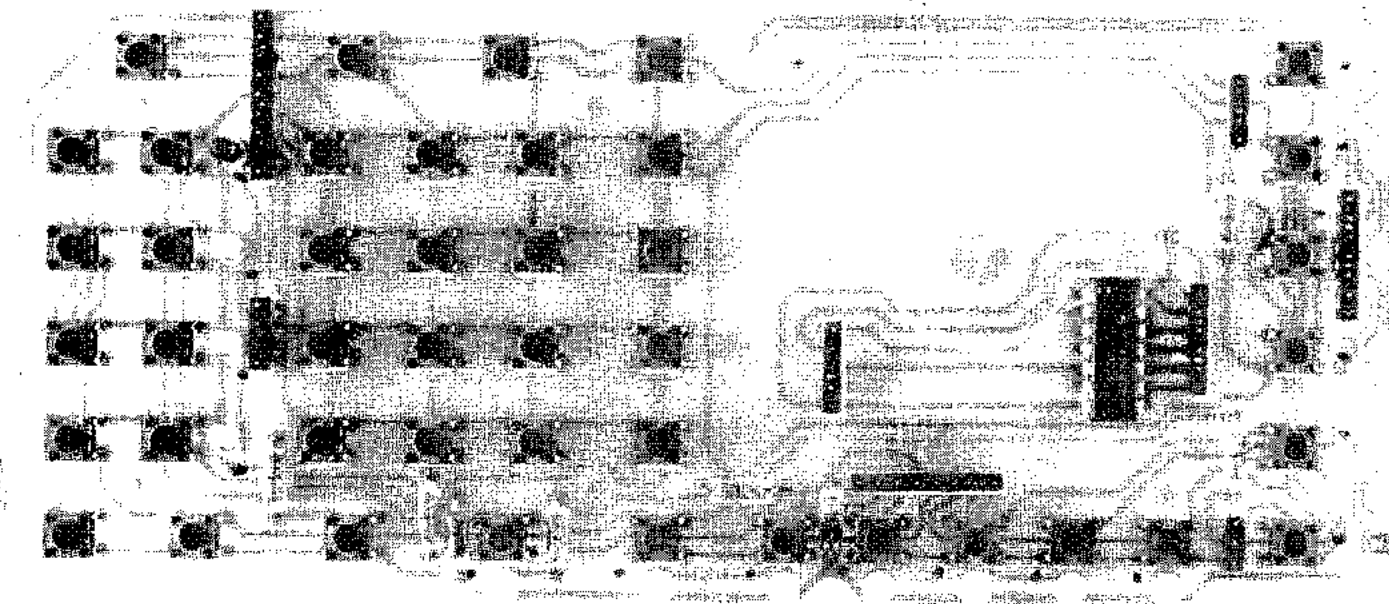

FIGURE 4-52. KEYPAD BOARD COMPONENT LAYOUT (81693)

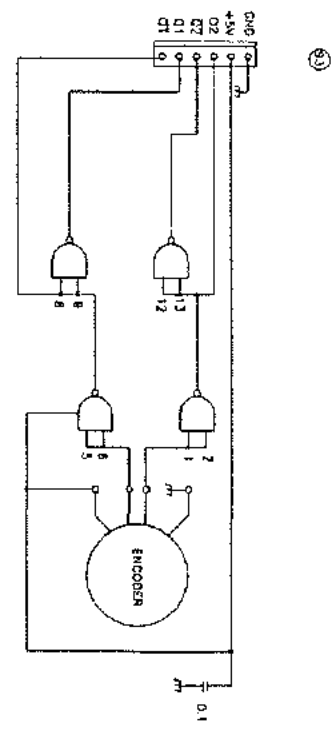
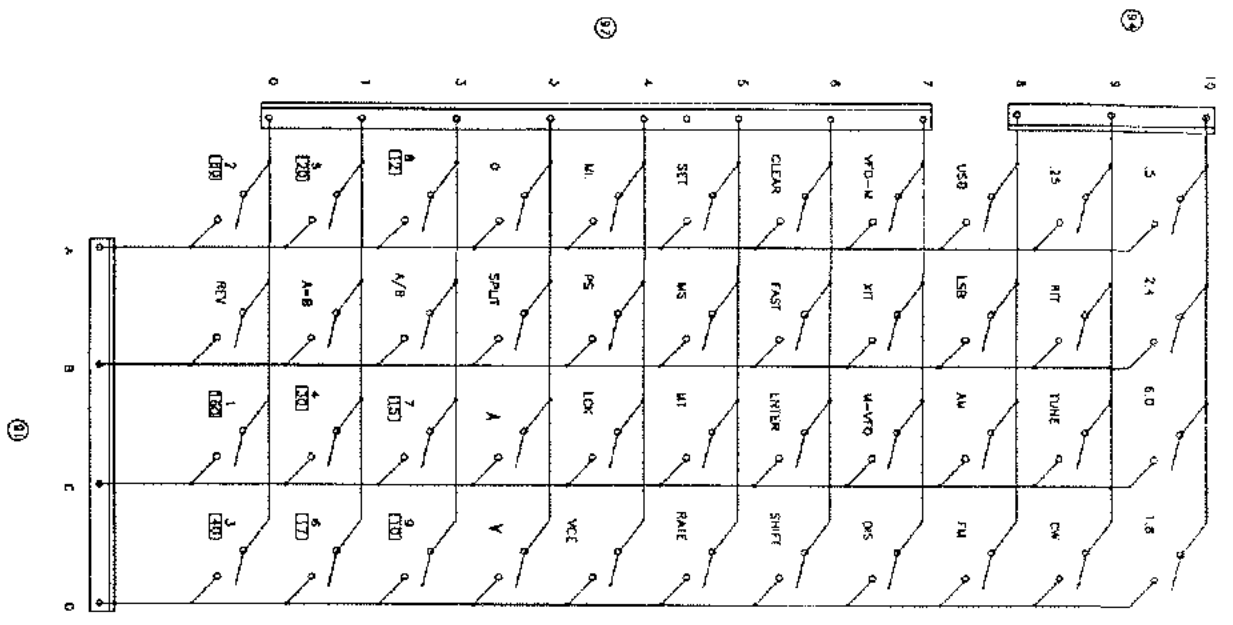

FIGURE 4-53. KEYPAD BOARD SCHEMATIC (81693)

RS232 INTERFACE CARD (81700)

This assembly contains the circuitry required to interface the PARAGON II with an external computer system via the DB-25 connector mounted on the rear panel of the unit. The interface is made up of U1, a CMOS Asynchronous Communications Interface Adapter, which provides bi-directional communications using the RS232 data format and timing specifications. This IC contains an integral baud rate generator and all required timing control circuitry. The baud rate, parity, and handshaking are all software programmable. For use in the PARAGON II, the baud rate is preset to 1200, with 8 data bits, 1 stop bit, and no parity. Programmable timing loops are required for reliable interfacing between the PARAGON II and an external computer. The advantage of programmable timing loops is that interface hardware requirements are simpler and less computer dependant.

The transmit data exits pin 10 of U1 and goes to two different places. The first path takes the transmit information at its TTL level and carries it to cable X where it is cabled on to the DB-25 Board. The other path is through Q3 and Q4 to connector W and pin 11 of U2. Connector W takes the transmit data to the CI-V interface located

on the rear panel of the unit, while U2 does a level conversion and outputs the transmit data on pin 14 at a RS232 level. The RS232 level is then cabled via connector X to the DB-25 Board. TTL level receive data enters at connector X and enters pin 12 of U1. RS232 receive data enters at connector X and proceeds to pin 13 of U2 where a level conversion is made and the TTL level is output at pin 12 of U2. At this point receive data passes through Q1 and Q2 and on to receive data input pin 12 of U1. If the CI-V interface is being used connector W brings the receive data through Q1 and Q2 into pin 12 of U1.

U2 is a MAX232 chip. This is an RS232 level conversion chip which converts the 0 to 5 Volt TTL signals to standard -10 to +10 Volt RS232 levels. U2 is powered from the 5V line and uses a built-in DC-to-DC converter to obtain the proper output conversion. The RS232 level transmit and receive data go to the DB-25 board via the normal or reverse position for cable X. If you are using a null-modem cable, the position of X should be normal (NORM).

NOTE: The PARAGON II is setup at the factory with cable X in the reverse (REV) position and will work with standard RS232 cables.

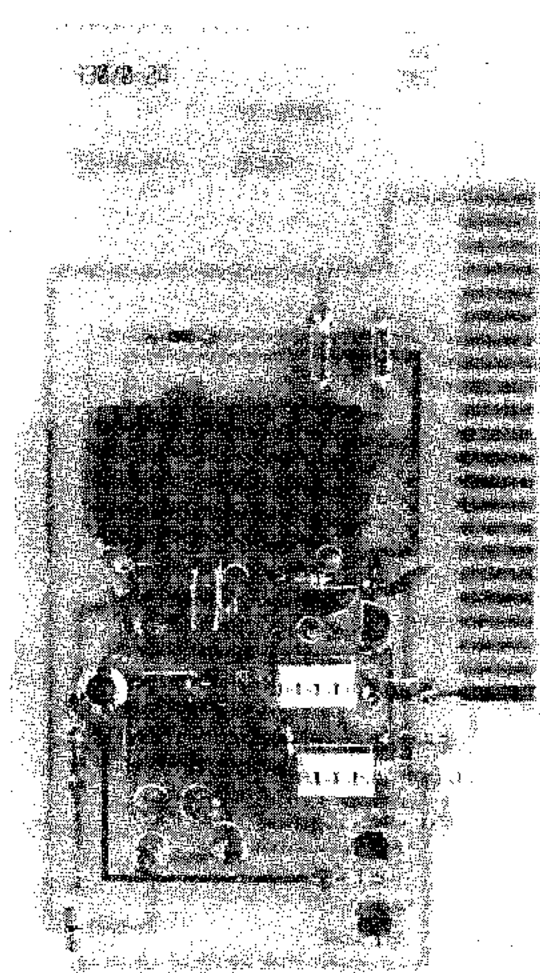
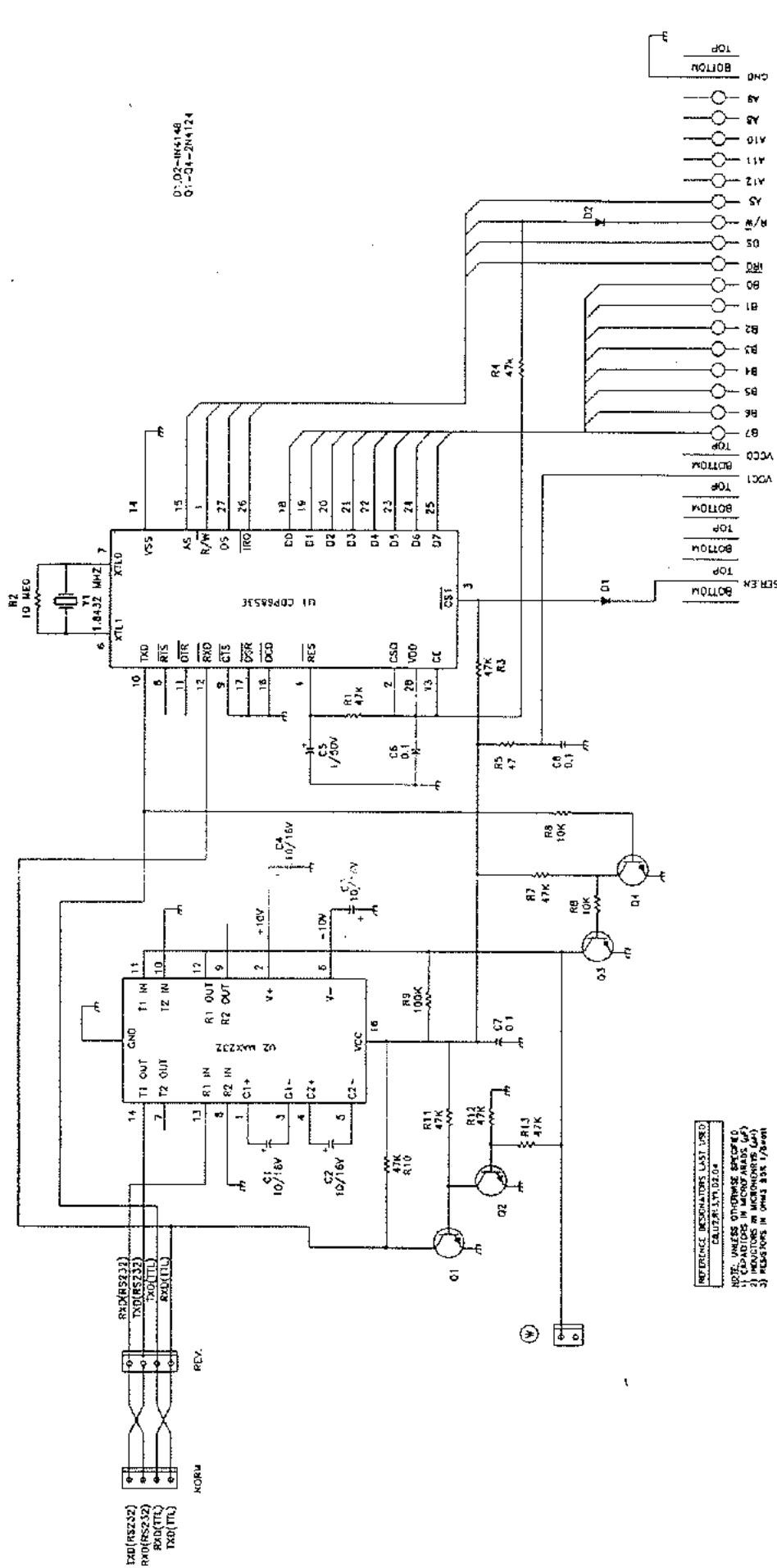

FIGURE 4-54. RS 232 INTERFACE COMPONENT LAYOUT (81700)

A B C D E F G H J K L M N



D: 03-1K6148
O: 04-2H4124

REFERENCE DESIGNATORS LIST USED
CALCULATED BY 1/10/04
NOTES: 1) ALL RESISTORS UNLESS OTHERWISE SPECIFIED
2) CAPACITORS IN MICROFARADS (UF)
3) INDUCTORS IN MICROHENRS (UH)
4) RESISTORS IN OHMS ARE 1/8Watt

81700 RS232 INTERFACE BOARD SCHEMATIC

RS232 51

FIGURE 4-55. RS 232 INTERFACE SCHEMATIC (81700)

CHAPTER 5 PARAGON II SERIAL INTERFACE

5.1 INTRODUCTION

The PARAGON II transceiver contains a comprehensive computer control interface. Remote control of many transceiver functions provide additional operator convenience and flexibility. The Serial Interface built into the PARAGON II was designed to be compatible with many existing contest and logging software packages. The PARAGON II factory settings allow it to emulate an ICOM 735 transceiver and your software should be configured to operate with the 735 until software vendors take advantage of the PARAGON II's extended command set.

For those that wish to write their own control program, the interface command structure and command set are included to help guide you through the process. FIGURE 5-1 shows how to connect your PARAGON II to a computer via the DB-25 connector. If this port is already in use, another serial port is available on the rear panel. The Model 305 serial level converter must be used when using this serial port with a computer.

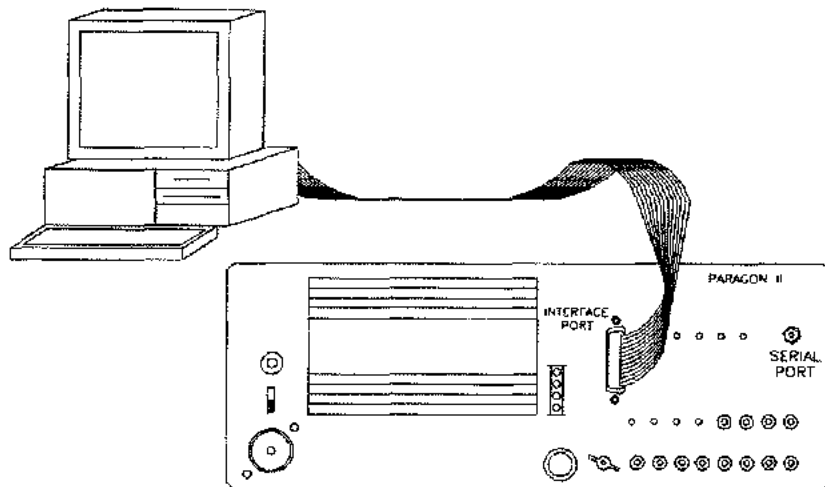

FIGURE 5-1 CONNECTION OF PARAGON II TO COMPUTER

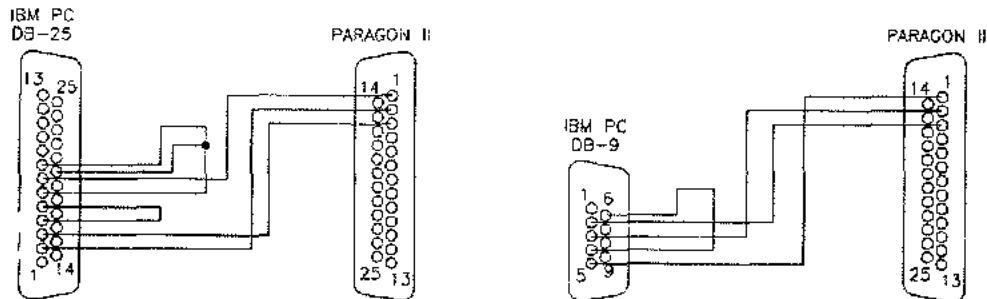

FIGURE 5-2 RS-232 CABLE WIRING CONNECTIONS

5.2 COMMAND/CONTROL OPERATIONS OF TEN-TEC TRANSCEIVERS

When connected to a personal computer, many transceiver operations can be controlled and/or queried remotely. Operating frequency, modes and memory selections can be controlled. There are many software packages available to control a transceiver while providing LOGGING and DATABASE features. Many of these programs are excellent and choosing one will be the quickest way to take advantage of remote transceiver operations.

The following information is supplied as reference if you choose to write your own transceiver control program since commands must be sent in a form that the transceiver will understand and can act upon. To communicate with a TEN-TEC Model 586, the personal computer must first be set-up properly. The computer's RS-232 port must be configured for a baud rate of 1200, NO parity, 8 data bits and 1 stop bit. Each transceiver has a unique identifier and in the TEN-TEC Model 586, the identifier may be set by pressing **SHIFT** followed by **SET** and then two desired digits. This identifier is a two digit number and the transceiver 'ADDRESS' as its called, must match the transceiver address in any software program. The displayed digits are a decimal representation of the address.

5.3 COMMAND/DATA FORMATS - COMPUTER TO TRANSCEIVER

Commands and data traveling from a host computer to a transceiver or vice versa must be properly encoded if the interface is to operate properly. The commands and data are sent as strings of numbers and/or characters that represent specific operations to a transceiver. Generally, operation involves sending a command to the transceiver and then waiting for the transceiver to respond. Depending on the command, the transceiver may respond with a string of characters indicating 'OK', meaning that the requested command has been processed. Alternately, the transceiver may respond with a string of characters indicating 'NO GOOD' to the computer, meaning that the transceiver was unable to process the request. Some commands, may result in the transceiver returning some operational information from the radio such as current frequency or mode. If a transceiver responds with a NO GOOD code, it was either because the command was not in the proper format or because the requested operation was not available on that transceiver.

The structure of the commands and responses is designed to limit the amount of data to be sent or received via the serial interface. This allows the interface to operate quickly. The general format of a command is shown below (sent left to right). Notice, that numeric codes are encoded in Hexadecimal format.

FE FE	RECEIVER ADDRESS	SENDER ADDRESS	COMMAND CODE	SUB COMMAND
DATA	FD			

The FE FE at the beginning of the string is the two byte code that tells the transceiver a command is to follow. The transceiver will prepare itself to check the command to determine if it contains its address, which tells the transceiver that it is to process the command that will follow. If the RECEIVER address in the command string, does not match the transceiver's address, the command is ignored by the transceiver. (There are a few exceptions to this rule to be discussed later). The SENDER address is a code that represents the address of the computer that is sending the command. This address will be used later by the transceiver when

it responds to the command request. Because the serial interface allows multiple computers to be used as well as multiple transceivers, each computer must have a unique address just as each transceiver is required to have a unique address. The default computer address used most is E0 Hex. The COMMAND CODE tells the transceiver which operation to perform. All command codes are in Hexadecimal format. Some commands contain additional Sub Commands that further clarify to the transceiver the specific operation that is to be performed. Specific codes may be found in the following pages.

The DATA portion of the command string is required by some commands. It will contain frequency or mode information if such commands are issued. The FD Hex. at the end of the command string, informs the transceiver that the end of the command has been reached. After a transceiver receives a complete command string, it will process the command.

5.4 RESPONSE STRINGS - RADIO TO COMPUTER

After a transceiver has processed a command sent from a computer, it will send a response back to the computer that originated the command. This insures that the computer knows how the transceiver handled the command and also provides a method of pacing the commands because the computer knows not to send additional commands until it has received a response from the transceiver concerning the last command sent. If a computer sends a command to a transceiver that is not a status requesting command (a command that requests data to be sent back) the transceiver will respond either with a code indicating OK (FB Hex.) or NO GOOD (FA Hex.). The returned string will have the following format. The same general structure as described above is maintained but the transceiver is now the sender and the computer is now the receiver.

FEh	FEh	RECEIVER ADDRESS	SENDER ADDRESS	FAh or FBh	FDh
-----	-----	------------------	----------------	------------	-----

5.5 DATA FORMATS

When a computer sends frequency or mode setting commands to a transceiver, the command string will necessarily contain the requested frequency data or mode code. Frequency data must be encoded as a string of BCD digits in the order shown below. Each Hexadecimal number contains 2 BCD digits and must be properly encoded for the transceiver to process them. When frequency data is requested from a transceiver, it will also be in this format.

1st byte		2nd byte		3rd byte		4th byte	
10Hz	1Hz	1Khz	100hz	100Khz	10Khz	10Mhz	1Mhz

FOR EXAMPLE: The frequency 14.03567 Mhz would be encoded as follows:

70 56 03 14

Since the TEN-TEC Model 586 has a tuning resolution of 10 Hz, and an upper frequency limit of 30 Mhz, the 1Hz digit is ignored and attempting to go beyond 30 Mhz will generate a 'NO GOOD' response from the transceiver.

When a mode selection command is sent, the mode must be encoded according to the following table:

LSB 00	FM 05
USB 01	FSK 04
AM 02	AM UPPER 06
CW 03	AM LOWER 07

When a transceiver returns its current operating mode to a computer, it will also be encoded in this format.

When a filter selection command is sent, the filter must be encoded according to the following table:

6.0 KHz	01
2.4 KHz	02
1.8 KHz	03
.5 KHz	04
.25 KHz	05

When the transceiver returns its current operating filter to a computer, it will also be in this format.

5.6 COMMANDS

Specific transceiver control commands can be found on the following pages. In use, each command must adhere to the structure discussed earlier. Included with the commands is a brief discussion of the possible transceiver response.

03h QUERY TRANSCEIVER FREQUENCY

This command sends the transceiver's current operating frequency to the requesting computer. The frequency data is returned as a string of BCD digits encoded as discussed previously.

COMMAND STRING SENT TO THE TRANSCEIVER:

FEh FEh RA SA 03h FDh
 FEh FEh Command Prefix
 RA Receiver Address (transceiver's address)
 SA Sender Address (computer E0h)
 03h Command code for frequency query
 FDh Command String Terminator

RESPONSE STRING SENT TO THE COMPUTER:

The transceiver will respond by sending a return string that contains a data segment with the transceiver's frequency encoded in BCD format. The returned frequency represents the frequency of the currently active VFO.

FEh FEh RA SA DATA FDh	
FEh FEh	Command Prefix
RA	Receiver Address (computer E0h)
SA	Sender Address (Transceiver's address)
DATA	Transceiver's frequency in BCD format
FDh	Command string terminator

04h QUERY TRANSCEIVER MODE

This command sends the transceiver's current operating mode to the requesting computer.

COMMAND STRING SENT TO THE TRANSCEIVER:

FEh FEh RA SA 04h FDh	
FEh FEh.	Command Prefix
RA	Receiver Address (transceiver's address)
SA	Sender Address (computer E0h)
04h	Command code for mode query
FDh	Command String Terminator

RESPONSE STRING SENT TO THE COMPUTER:

The transceiver will respond by sending a return string that contains a data segment with the transceiver's mode encoded. The mode returned is from the displayed VFO.

FEh FEh RA SA DATA FDh	
FEh FEh	Command Prefix
RA	Receiver Address (computer E0h)
SA	Sender Address (Transceiver's address)
MODE DATA	Transceiver's mode encoded
FILTER DATA	Transceiver's filter encoded
FDh	Command String Terminator

05h SET TRANSCEIVER FREQUENCY

This command updates the frequency of the currently selected VFO to data contained in the command string. Frequency data must be encoded.

COMMAND STRING SENT TO THE TRANSCEIVER:

FEh FEh RA SA 05h DATA FDh
FEh FEh Command Prefix
RA Receiver Address (transceiver's address)
SA Sender Address (computer E0h)
05h Command code for mode query
DATA BCD encoded frequency data
FDh Command String Terminator

RESPONSE STRING SENT TO THE COMPUTER:

The transceiver will send a string that contains either the OK code (FBh) or a NO GOOD code if the operation failed. The operation will fail if the frequency data indicates a frequency that is beyond the capabilities of the transceiver.

FEh FEh RA SA FAh or FBh FDh
FEh FEh Command Prefix
RA Receiver Address (computer E0h)
SA Sender Address (Transceiver's address)
FAh or FBh NO GOOD CODE or OK CODE
FDh Command String Terminator

06h SET TRANSCEIVER MODE

This command changes the mode of the currently selected VFO to data contained in the command string. Mode data must be encoded.

COMMAND STRING SENT TO THE TRANSCEIVER:

FEh FEh RA SA 06h DATA FDh
FEh FEh Command Prefix
RA Receiver Address (transceiver's address)
SA Sender Address (computer E0h) 06h = Command code for mode query 06h
MODE DATA Desired mode encoded
FILTER DATA Desired filter encoded (optional)
FDh Command String Terminator

RESPONSE STRING SENT TO THE COMPUTER:

The transceiver will respond by sending a string containing either the OK code (FBh) if the operation was performed, or a NO GOOD (FAh) code if the operation failed. The operation will fail if the requested mode is not available on the transceiver.

FEh FEh RA SA FAh or FBh FDh
 FEh FEh Command Prefix
 RA Receiver Address (computer E0h)
 SA Sender Address (Transceiver's address)
 FAh or FBh NO GOOD CODE or OK CODE.
 FDh Command String Terminator

07h VFO SELECTION

This command provides for selection of a particular VFO. Besides the VFO selection code 07h, a sub command must be specified that indicates which VFO operation to perform.

COMMAND STRING SENT TO THE TRANSCRIVER:

FEh FEh RA SA 07h SC FDh
 FEh FEh Command Prefix
 RA Receiver Address (transceiver's address)
 SA Sender Address (computer E0h)
 07h Command code for mode query
 SC Sub-Command:
 00h Select VFO A
 01h Select VFO B
 A0h Copies selected VFO to other VFO. ie VFO A = VFO B.
 B0h Swaps VFO contents. ie VFO A to VFO B and VFO B to
 VFO A.
 FDh Command String Terminator

RESPONSE STRING SENT TO THE COMPUTER:

The transceiver responds by sending a string containing either the OK code (FBh) if the operation was performed, or a NO GOOD code if the operation failed. The operation will fail if the requested mode is not available on the transceiver.

FEh FEh RA SA FAh or FBh FDh
 FEh FEh Command Prefix
 RA Receiver Address (computer E0h)
 SA Sender Address (Transceiver's address)
 FAh or FBh NO GOOD CODE or OK CODE.
 FDh Command String Terminator

08h SELECT MEMORY CHANNEL

This command informs the transceiver which memory channel is to be used for subsequent memory operations. The memory channel number, in BCD format, must be within the memory channel limits of the transceiver or a NO GOOD will be returned.

COMMAND STRING SENT TO THE TRANSCEIVER:

FEh FEh RA SA 08h MC FDh	
FEh FEh	Command Prefix
RA	Receiver Address (transceiver's address)
SA	Sender Address (computer E0h)
08h	Command code for memory channel query
MC	Memory channel number in BCD format
FDh	Command String Terminator

RESPONSE STRING SENT TO THE COMPUTER:

The transceiver responds by sending a string containing either the OK code (FBh) if the operation was performed, or a NO GOOD code if the operation failed. The operation will fail if the memory channel is not available on the transceiver.

FEh FEh RA SA FAh or FBh FDh	
FEh FEh	Command Prefix
RA	Receiver Address (computer E0h)
SA	Sender Address (Transceiver's address)
FAh or FBh	NO GOOD CODE or OK CODE.
FDh	Command String Terminator

09h TRANSFER ACTIVE VFO TO MEMORY CHANNEL

This command transfers contents of the active VFO to the pre-specified memory channel. The memory channel should have been previously set using command 08h. If not, the last accessed memory channel will be used for the operation.

COMMAND STRING SENT TO THE TRANSCEIVER:

FEh FEh RA SA 09h FDh	
FEh FEh	Command Prefix
RA	Receiver Address (transceiver's address)
SA	Sender Address (computer E0h)
09h	Command code for active VFO to memory query
FDh	Command String Terminator

RESPONSE STRING SENT TO THE COMPUTER:

The transceiver responds by sending a string containing either the OK code (FBh) if the operation was performed, or a NO GOOD code if the operation failed.

FEh FEh RA SA FAh or FBh FDh	
FEh FEh	Command Prefix
RA	Receiver Address (computer E0h)
SA	Sender Address (Transceiver's address)
FAh or FBh	NO GOOD CODE or OK CODE.
FDh	Command String Terminator

0Ah COPY MEMORY CHANNEL TO ACTIVE VFO

Transceiver to copy data from the pre-specified memory channel into the currently active VFO. The memory channel should have been previously set using command 08h. If not, the last accessed memory channel will be used for the operation.

COMMAND STRING SENT TO THE TRANSCEIVER:

FEh FEh RA SA 0Ah FDh	
FEh FEh	Command Prefix
RA	Receiver Address (transceiver's address)
SA	Sender Address (computer E0h)
0Ah	Command code for memory channel to Active VFO query
FDh	Command String Terminator

RESPONSE STRING SENT TO THE COMPUTER:

Transceiver responds by sending a string containing either the OK code (FBh) if the operation was performed, or a NO GOOD code if the operation failed.

FEh FEh RA SA FAh or FBh FDh	
FEh FEh	Command Prefix
RA	Receiver Address (computer E0h)
SA	Sender Address (Transceiver's address)
FAh or FBh	NO GOOD CODE or Ok CODE.
FDh	Command String Terminator

0Fh SET/CANCEL SPLIT OPERATION

This command activates or cancels split operation of the transceiver. In addition to the SET/CLEAR SPLIT command code 0Fh, a sub command must be specified to indicate which operation to perform.

COMMAND STRING SENT TO THE TRANSCEIVER:

FEh FEh RA SA 0Fh SC FDh
FEh FEh Command Prefix
RA Receiver Address (transceiver's address)
SA Sender Address (computer E0h)
0Fh Command code for split query
SC Sub-command:
 00h = cancel split operation
 01h = Set split operation
FDh Command String Terminator

RESPONSE STRING SENT TO THE COMPUTER:

Transceiver responds by sending a string containing either the OK code (FBh) if the operation was performed, or a NO GOOD code if the operation failed.

FEh FEh RA SA FAh or FBh FDh
FE FE Command Prefix
RA Receiver Address (computer E0h)
SA Sender Address (Transceiver's address)
FAh or FBh NO GOOD CODE or OK CODE.
FD Command String Terminator

SPECIALIZED COMMAND MODES:

Some transceivers, such as TEN-TEC models 535, 536, 563, and 586 provide an additional mode referred to as MATRIX MODE. MATRIX MODE allows a transceiver to operate as a controller for other transceivers connected to the serial interface. When the transceiver is placed in MATRIX MODE it will generate and accept MATRIX MODE COMMANDS. These commands are sent from any transceiver placed in MATRIX MODE and are in a format unique to MATRIX MODE. Other MATRIX MODE transceivers will accept the matrix mode commands but will not generate response. MATRIX MODE commands are generated from a MATRIX MODE transceiver when ever its operating status is changed (ie. frequency or mode). By sending MATRIX MODE commands that contain this information, other MATRIX MODE transceivers will automatically track the transceiver that generated the commands. To activate MATRIX MODE on Models 535/536: press SHIFT and SPLIT. M.Lock will appear in display. To activate MATRIX mode on Model 563: in USER'S MENU, turn CdE ON. In TEN-TEC Model 586, press "SHIFT" followed by "A/B". Notice the "M" indicating MATRIX MODE next to clock. To exit MATRIX MODE in 586, do the same.

<p>00h MATRIX MODE COMMAND TRANSFER CURRENT OPERATING FREQUENCY TO ALL TRANSCEIVERS IN MATRIX MODE</p>

This command, generated by a transceiver in MATRIX MODE, causes any other MATRIX MODE transceiver to mimic the operation of the transceiver that generated this command.

COMMAND STRING SENT TO THE TRANSCEIVER:

FEh FEh RA SA 00h DATA FDh	
FEh FEh	Command Prefix
RA	00h Receiver Address that any MATRIX MODE transceiver will accept.
SA	Sender Address (transceiver address)
00h	Command code for frequency query
DATA	Transceiver frequency, encoded in BCD format
FDh	Command String Terminator

RESPONSE STRING SENT TO THE COMPUTER: No transceiver responds to this transceiver generated command.

01h MATRIX MODE COMMAND TRANSFER CURRENT OPERATING MODE TO ALL TRANSCEIVERS IN MA- TRIX MODE

This command, generated by a transceiver in MATRIX MODE, causes any other MATRIX MODE transceiver to mimic the operation of the transceiver that generated this command.

COMMAND STRING SENT TO THE TRANSCEIVER:

FEh FEh RA 00h SA 01h DATA FDh	
FEh FEh	Command Prefix
RA	00h Receiver Address that any MATRIX MODE transceiver will accept.
SA	Sender Address (transceiver address)
01h	Command code for mode query 01h
DATA	mode code, encoded in BCD.
FDh	Command String Terminator

RESPONSE STRING SENT TO THE COMPUTER: No transceiver responds to this transceiver generated command.

5.7 EXPANDED COMMANDS FOR THE OMNI VI AND PARAGON II, MODELS 563 AND 586 ONLY

0C HEX: READ OFFSET FREQUENCY

This command queries the transceivers current offset frequency.

Transceiver's response: The transceiver will respond by returning the current offset frequency in BCD format (2 bytes). Negative offset frequencies are returned in 9's complement form.

Data: Transceiver's current offset frequency in BCD format.

0D HEX: WRITE OFFSET FREQUENCY

This command sets the transceivers current offset frequency.

Data: Offset frequency in BCD format. For negative values of offset, the format should be 9' complement.

13 HEX: ANNOUNCE FREQUENCY OF CURRENT VFO (OPTIONAL VOICE BOARD REQUIRED)

This command will activate the optional voice board and announce the frequency of the current VFO.

Transceiver's response: Returns NO GOOD if the voice board is not installed.

16 HEX: SET/CLEAR TRANSMIT MODE

This command and associated sub-commands control the transmitter.

These commands provide remote control of the transmit/receive functions but cannot override local control functions. Thus, if the PTT line is depressed, sending a RETURN TO RECEIVE command cannot override the PTT action.

SUB-COMMAND 01h	GO TO TRANSMIT
SUB-COMMAND 02h	RETURN TO RECEIVE

Transceiver's response: If the transceiver was able to perform the indicated operation, it will return the OK code.

COMMAND 17h: RETURN TRANSCEIVER STATUS

This command queries the transceiver's extended status information.

Transceiver's response: The transceiver will return the extended status information encoded in a 1 byte code encoded as listed below.

BIT POSITION

0	SPLIT STATUS	(0=SPLIT OFF, 1=SPLIT ON)
1	VFO SELECTED	(0=VFO A, 1=VFO B)
2	TX STATUS	(0=RX, 1=TX)
3	RIT STATUS	(0=OFF, 1=ON)
4	XIT STATUS	(0=OFF, 1=ON)
5	VOX STATUS	(0=OFF, 1=ON)
6	LOCK STATUS	(0=OFF, 1=ON)
7	NOT USED	

18h RETURN TRANSMIT FREQUENCY

This command returns the true transmit frequency of the transceiver. Any transmit offset or split status will be included in the returned frequency.

COMMAND STRING SENT TO THE TRANSCEIVER:

FEh FEh RA SA 18h FDh	
FEh FEh	Command Prefix
RA	Receiver Address (transceiver's address)
SA	Sender Address (computer E0h)
18h	Command code for true transmit frequency query
FDh	Command String Terminator

RESPONSE STRING SENT TO THE COMPUTER:

The transceiver will respond by sending a return string that contains a data segment with the transceiver's true transmit frequency encoded in BCD format.

FEh FEh RA SA DATA FDh	
FEh FEh	Command Prefix
RA	Receiver Address (computer E0h)
SA	Sender Address (Transceiver's address)
DATA	Transceiver's true transmit frequency in BCD format
FDh	Command string terminator

19h RETURN RECEIVE FREQUENCY

This command returns the true receive frequency of the transceiver. Receive offset and split operation are included in the returned frequency.

COMMAND STRING SENT TO THE TRANSCEIVER:

FEh FEh RA SA 19h FDh	
FEh FEh	Command Prefix
RA	Receiver Address (transceiver's address)
SA	Sender Address (computer E0h)
19h	Command code for true receive frequency query
FDh	Command String Terminator

RESPONSE STRING SENT TO THE COMPUTER:

The transceiver will respond by sending a return string that contains a data segment with the transceiver's true receive frequency encoded in BCD format. The returned frequency represents the frequency of the currently active receive VFO.

FEh FEh RA SA DATA FDh	
FEh FEh	Command Prefix
RA	Receiver Address (computer E0h)
SA	Sender Address (Transceiver's address)
DATA	Transceiver's true transmit frequency in BCD format
FDh	Command string terminator

Ten-Tec, Inc.
1185 Dolly Parton Parkway
Sevierville, TN 37862
Repair Service: (865) 428-0364

LIMITED WARRANTY AND SERVICE POLICY, U.S.A. AND CANADA

Ten-Tec, Inc., warrants this product to be free from defects in material and workmanship for a period of one (1) year from the date of purchase, under these conditions:

1. THIS WARRANTY APPLIES ONLY TO THE ORIGINAL OWNER. It is important that the warranty registration card be sent to us promptly.
2. READ THE MANUAL THOROUGHLY. This warranty does not cover damage resulting from improper operation. Developing a thorough understanding of this equipment is your responsibility.
3. IF TROUBLE DEVELOPS we recommend you contact our customer service group direct at the address or phone number shown above. It has been our experience that factory direct service is expeditious and usually results in less down-time on the equipment. Some overseas dealers do offer warranty service and, of course, have our complete support.
4. EQUIPMENT RETURNED TO THE FACTORY must be properly packaged, preferably in the original shipping carton(s). You pay the freight to us and we prepay surface freight back to you. Canadian customers must have proper customs documentation sent with incoming repair equipment. Duties or fees charged due to improper documenting are the responsibility of the owner of the equipment.
5. EXCLUSIONS. This warranty does not cover damage resulting from misuse, lightning, excess voltages, polarity errors or damage resulting from modifications not recommended or approved by Ten-Tec. In the event of transportation damage, a claim must be filed with the carrier. Under no circumstances is Ten-Tec liable for consequential damages to persons or property caused by the use of this equipment.
6. TEN-TEC RESERVES the right to make design changes without any obligation to modify equipment previously manufactured, or to notify owners of changes to existing equipment.
7. THIS WARRANTY is given in lieu of any other warranty, expressed or implied.

SERVICE OUTSIDE OF THE U.S.A. OR CANADA

Many of our international dealers provide warranty service on the equipment they sell. Many of them also provide out of warranty service on all equipment whether they sold it or not. If your dealer does not provide service or is not conveniently located, follow the procedure outlined above. Equipment returned to us will be given the same attention as domestic customers but roundtrip freight expense, customs and broker fees will be paid by you.

Part no. 74244

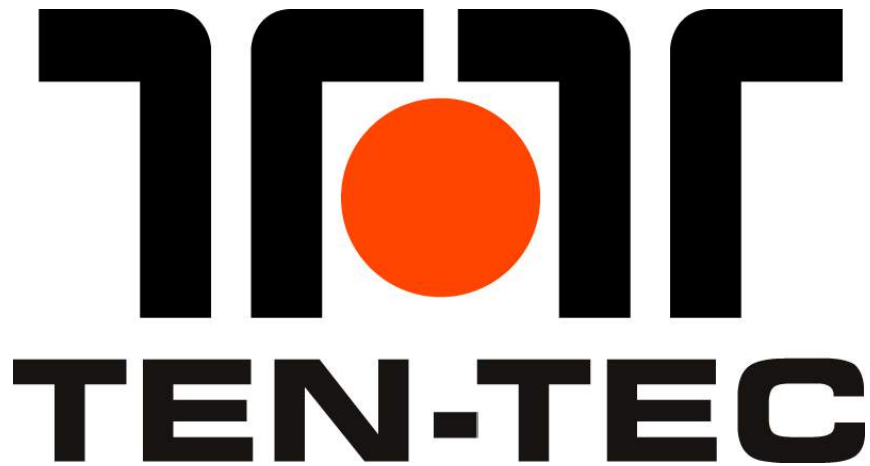

This obsolete manual file is provided as a courtesy to you by Ten-Tec, Inc.

Ten-Tec's service department can repair and service virtually everything we have built going back to our first transceivers in the late 1960's. It is our ability to continue offering service on these rigs that has led to their re-sale value remaining high and has made a major contribution to our legendary service reputation.

Printed and bound copies of all manuals are available for purchase through our service department if you would prefer not to use this copy as your transceiver manual.

We can repair or service your Ten-Tec equipment at our facility in Sevierville, TN. We also offer support via telephone for all products via during usual business hours of 8 a.m. to 5 p.m. USA Eastern time, Monday through Friday. We have a large supply of parts for obsolete products. Repairing a transceiver or amplifier yourself? Contact us for parts pricing information.

**Service department direct line: (865) 428-0364
Ten-Tec office line: (865) 453-7172
Service department email: service@tentec.com
Address: 1185 Dolly Parton Parkway, Sevierville, TN 37862 USA**

We have found it is most effective for us to help you troubleshoot or repair equipment with a consultation via telephone rather than by email.

Suggested contact methods are:

**Troubleshooting or repairing equipment – call (865) 428-0364
Other inquiries – call (865) 428-0364 or email service@tentec.com**

THANK YOU AND 73 FROM ALL OF US AT TEN-TEC