

1

2

3

4



Button/Knob	Initial Setting fccw means fully clockwise	function fccw means fully counterclockwise	Manual Reference
1 Power	OFF (out)	power up functions	13
Tuner	ON (in)	autotuner momentary ON/OFF ½ sec force tuning	20
Meter	toggle	TRX/TX, RX/TX/ALC, RX/TX/SWR	17,49
Proc	OFF	increase average power in SSB and AM	21
ATT IPO	OFF/OFF	reduce strong signals/turn off receiver RF amp	18
NB	OFF	noise blanker for pulse noise	18
Split	Off	hidden (back) freq xmits	25
Ham/Gen	Ham	tuning mode/general purpose band; up/down	15
Fast	OFF	tuning speed	16
2 Mox	OFF (out)	manually keys transmitter	47
Vox	OFF (out)	voice activated T/R switching	
AGC-F	ON (in)	AGC decay time for fast recovery	18
Mic Gain	12 o'clock	Mic input for SSB and AM; watch ALC meter	20
RF Pwr	OFF (fccw)	10 to 100 watts	47
Speed		CW internal keyer speed	
Keyer		internal CW keyer	23
BK-IN		CW mode	
3 A/B	VFO-A	VFO selector toggle, ½ sec push equalizes A=B	26
V/M	VFO-A	toggle between VFO/Memory	
V->M		½ sec push: VFO to currently selected memory	26
M->V		½ sec push: pair of freqs in memory to VFOs	26,28
Down/Up	Band selection		
Lock	OFF	tuning knob	17
CLAR	OFF	fine tuning AM/FM	18, 25
AF/SQL	10 o'clock/OFF (fccw)	audio level/squelch	
Notch/Shift	12 o'clock/12 o'clock	Notch filter/shift center freq	18
4 Numeric Keypad		BAND or <Ent> freq <Ent>	16
Gen		general purpose band	

Power-Up Customization: Notch Down Up Fast FM Up+Down V/M Lock V->M Clar Meter

YAESU HF TRANSCEIVER FT-900

VFD-A
USB
14.320.00 01 CH
FAST S 1 • 3 • 5 • 7 • 9 +20 +40 +60dB
0 10 25 50 100 150W
SWR 1.0 1.5 2.0 3.0 5.0 ∞

POWER
TUNER
METER
MIC

SSB
C W
A M
F M

TRANSMIT BUSY

A/B V/M V>M M>V

DOWN UP

CLAR - +

AF → SQL

NOTCH → SHIFT

PROC ATT IPO NB SPLIT HAM/GEN

FAST

LOCK

PHONES MOX VOX AGC-F MIC GAIN RF PWR SPEED — KEYER BK-IN

1.8 3.5 7 10 14 ENT
1 2 3 4 5
18 21 24.5 28 29 GEN
6 7 8 9 0

YAESU

FT-900

OPERATING MANUAL

YAESU MUSEN CO., LTD.
C.P.O. Box 1500, Tokyo, Japan
YAESU U.S.A.
17210 Edwards Rd., Cerritos, California 90703
U.S.A.
YAESU EUROPE B.V.
Snipweg 3, 1118DN Schiphol, The Netherlands
YAESU UK LTD.
Unit 2, Maple Grove Business Centre
Lawrence Rd., Hounslow, Middlesex TW4 6DR, UK

Important Advice on Mobile Installation and Operation

The following tips are designed to improve results when using the FT-900 in mobile installations. Adhering to these suggestions can reduce difficulties resulting from improper grounding, high SWR, feedline radiation and RFI. Complete installation instructions are included with the YSK-900 Separation Kit and FC-800 Automatic External Antenna Tuner (if used). Please read the information provided with them thoroughly before beginning your installation.

It is important to remember that mobile installations often present special challenges to the owner, because satisfactory *RF grounding* (as opposed to DC grounding) may be difficult to obtain at all frequencies of interest. The use of a remote control head (via the YSK-900 Kit) adds signal and ground paths which must be considered. With thoughtful planning and careful installation, your mobile communication system performance with the FT-900 should be excellent.

1. When installing the FT-900 with the YSK-900 Separation Kit, refrain from mounting the sub panel in close proximity to the transmitting antenna. The strong RF field near the base of the mobile antenna may cause the sub-panel to not operate properly if the two are mounted too close together.

2. Provide separate chassis ground connections for the transceiver and antenna mounting base. The shield of the coax cable, though it may connect to the base of the mobile antenna, does not establish a satisfactory RF ground by itself. Without solid grounding of the mounting plate for the mobile antenna, RF currents may flow on the shield of the coaxial cable, leading to RF feedback, noise, and generally erratic operation.

3. If at all possible, the mobile antenna should be tuned for minimum SWR (less than 2:1 at the center frequency of interest) at the antenna feedpoint. Because most mobile antennas have a very narrow SWR bandwidth, it is important to establish the lowest possible center frequency so to allow as much latitude as possible for frequency excursions away from the central frequency. The ATU-2 internal antenna tuner will provide much better operating bandwidth if the (central operating frequency) SWR is low.

4. During installation, do not route the DC power cable, antenna coaxial cable and sub-panel control cable together in parallel; route them along separate paths, if possible. If you have excess lengths of cable, coil and tape them up neatly, but avoid placing loops from different cables on top of one another.

5. Use the FT-900's internal antenna tuner (ATU-2) to resonate the mobile antenna plus feedline system in most installations. Even though the feedline may carry a 3:1 SWR at some frequencies away from resonance, the very short feedline length yields negligible SWR-related cable loss in most mobile setups.

6. Should circumstances dictate the use of a non-resonant whip in conjunction with the FC-800 external tuner, a general guideline is to mount the FC-800 as far as practical from the FT-900, with the antenna as close as possible to the FC-800 feedpoint. Keep in mind that the external tuner itself becomes part of the antenna system. Provide a good RF ground connection for the tuner by using a short, braided grounding strap.

Follow the installation instructions provided with the FC-800, and ensure the supplied toroidal choke is installed in-line to suppress RF currents on the cabling. Yaesu recommends a minimum of 5 meters (16 feet) of coaxial cable be used between the FT-900 and FC-800. If you experience RFI (feedback, transmit distortion, etc.), try installing a separate common-mode filter in the coaxial line between the transceiver and tuner. A coil of 15 cm (6 ") diameter made from 8~10 turns of coaxial cable taped tightly together may work well.

7. To prevent vehicle noise from being superimposed on your transmitted audio, pay particular attention to your **MIC GAIN** and (when using the speech processor) **COMP** controls. Do not exceed the 12-o'clock position of the **COMP** level control.

YAESU
Performance without compromise.SM

General Description



Congratulations on the purchase of your Yaesu amateur transceiver! Whether this is your first rig, or if Yaesu equipment is already the backbone of your station, rest assured that your transceiver will provide many hours of operating pleasure for years to come.

We want you to feel that you are now a part of the Yaesu Team, after all, we also share the exciting hobby of amateur radio communications you do. In fact, Yaesu Musen's history in Amateur Radio goes back to 1959, being the first to introduce and manufacture quality, high-performance SSB transceivers for the amateur market. Yaesu Musen also manufactures a broad range of high-quality commercial equipment that public services, businesses and mariners depend on every day.

Following the same tradition of excellence and innovation into the twenty first century, Yaesu Musen paves the way, incorporating the latest microprocessor and RF technology in our communications equipment. Yaesu transceivers have scaled mountains, crossed storm-tossed oceans and even orbited Earth. Some Yaesu equipment are legends in themselves, such as the classic FT-101E, and the industry standard of excellence, the FT-1000. Each Yaesu model is the result of extensive research, design and development. Most Yaesu engineers are also licensed amateurs, and they design transceivers with operators in mind. The product of this combined effort is evident in Yaesu equipment's rugged construction, comfortable operation, and of course, high performance.

But the effort doesn't stop here. With the progression of amateur radio along with the high-technology race, each transceiver incorporates a wealth of operating features to help you "keep up with the crowd". User-friendly controls and programming let you easily

manage your new operating capabilities, with just a few simple keystrokes!

Along with the philosophy that each Yaesu transceiver should serve you well into the future, Yaesu stands behind our products with a worldwide network of dealers and service centers. Feel free to contact us if you ever need technical advice or assistance.

Your FT-900 is a high-performance transceiver providing up to 100 watts transmitter output power on all HF amateur radio bands in CW, SSB and FM modes, and up to 25 watts carrier in AM. The receiver tunes all frequencies between 100 kHz and 30 MHz in 2.5-Hz steps.

For mobile operation, a new lightweight detachable sub-panel permits separating the transceiver and mounting the rear main unit in a remote location, keeping the most-commonly used front panel controls and display where you need them—in a comfortable, safe location (YSK-900 Separation Kit required for separate installation). This makes the FT-900 convenient for mobile and maritime amateur operation, or wherever space is critical.

Operating frequency and other important settings are displayed on a high-contrast backlit LCD. The new three-mode bargraph meter display features delayed "peak hold" circuitry for the tuning bargraph segments that simplifies tuning stations with rapidly varying signal strength. The new flexible mounting scheme combined with the famous high-performance circuitry of the earlier FT-890 is combined to form a compact, reliable rig that is ideally suited for base or mobile operation.

CW enthusiasts will enjoy the new CW reverse-sideband, which lets you switch the receiver carrier point (offset) to help sidestep QRM, and not have to

retune stations when switching between LSB and CW (convenient when working on 40 meters and below). If you use a multi-mode TNC or CW decoder, the adjustable BFO offset lets you match the CW pitch to that used by your unit so that the tuned station will be centered in the receiver IF passband, and your decoder will give optimum copy. The FT-900 full-featured internal electronic keyer allows front panel control of keying speed, weighting and mode (semi-/full break-in).

Modern circuit design employs surface-mount components on composite epoxy boards for high reliability and serviceability. Twin direct-digital synthesizers (DDSs) and a magnetic rotary encoder with selectable 2.5-, 5- or 10-Hz tuning steps provide silent, silky-smooth tuning, pure local signals and very fast tx/rx changeover important when operating QSK CW. Frequency accuracy and stability are assured by driving both DDSs from a single master oscillator, and the optional TCXO-3 temperature-compensated crystal oscillator is available for enhanced ± 2 -ppm stability from $0^{\circ} \sim +50^{\circ} \text{C}$.

The low-noise, high performance receiver front end uses parallel high-IDSS FETs in a constant-gain, grounded-gate RF amplifier, feeding an active double-balanced quad FET-ring mixer. The RF amplifier can be bypassed for direct-feed to the mixer (by the IPO button), and a 12-dB attenuator can be inserted for clear copy of even very strong signals.

Interference rejection is facilitated by the unique "up-down" conversion scheme, and includes an IF shift and notch circuit. The optional XF-110S crystal filter can be installed for enhanced SSB and AM narrow-skirt selectivity.

Four microprocessors in the FT-900 are programmed to provide the simplest possible control interface for the operator. Two independent (A/B) VFOs for each band (20 total) hold their own frequencies and modes settings. One hundred memories store all of this data for both VFOs, giving a total of 220 independent sets of frequency, mode and other selections.

Flexible scanning features allow all 100 memories or only those selected to be freely-tuned and scanned. In addition, ten special memories also let you limit the tuning/scanning range between their stored frequencies. Scan resume mode is selectable between timed or carrier-delay, and scanning speed is also adjustable.

Other valuable features include an effective noise blanker, all-mode squelch, multi-function meter, and an AF speech processor with adjustable IF offset which lets you increase the average power of your SSB signal and allows tailoring audio response to your voice characteristics. The FT-900 weighs under 5.5 kg and an internal thermally-switched fan allows full transmitter output without any rear panel protrusions, giving easy access to rear panel controls and connectors.

A choice of automatic antenna tuners is available for the FT-900, each with its own microprocessor and 31 memories which store most recent antenna matching settings for nearly instant recall while changing operating frequency. The ATU-2 can be mounted inside the transceiver, while the FC-800 can be installed remotely at the antenna feedpoint. Each antenna tuner is controlled from the front panel of the FT-900.

The MH-31A8J hand microphone is supplied with FT-900. Other accessories include the FP-800 AC Power Supply with Loudspeaker; the SP-6 External Loudspeaker with audio filters and optional LL-5 Phone Patch and the MMB-20 Mobile Mounting Bracket.

Before connecting the power cord, you should read the Installation section carefully, heeding the warnings in that section to avoid damage to the set. After installation, please take time to work through the Operation chapter, referring to the fold-out panel diagrams at the back of the manual as necessary for details. This manual is intended to be read while sitting down in front of the FT-900, so you can try out each control and feature as they are described.

Specifications

General

Receiving frequency range: 100 kHz ~ 30 MHz

Transmitting frequency ranges:

160 ~ 10 meter Amateur Bands

Frequency stability: ± 10 ppm (SSB, CW, AM) from -10° ~ $+50^{\circ}$ C or ± 2 ppm from 0° ~ 50° C (SSB, CW, AM w/TCXO-3 option)

Emission modes: USB, LSB(J3E), CW(A1A), AM(A3E), FM (F3E)

Frequency Tuning Steps:

2.5 Hz/ 5.0 Hz/ 10 Hz (CW, SSB)
100 Hz (AM, FM)

Antenna impedance: 50 Ω nominal(w/o ATU)
16.7 - 150 Ω with ATU (unbalanced)

Operating temp. range: -10° C ~ $+50^{\circ}$ C

Supply voltage: 13.5-V DC $\pm 10\%$, negative ground

Power consumption (approx): 1.5 A rx (no signal)
20 A tx (100 watts)

Dimensions (WHD): 238 x 93 x 253 mm (w/o knobs)

Weight (approx): 5.3 kg

Transmitter

Power output: adjustable up to 100 watts
(25 watts AM carrier)

Modulation types: SSB: Balanced, filtered carrier
AM: Low-level (early stage) FM: Variable reactance

Maximum FM deviation: ± 2.5 kHz

Harmonic radiation: 50 dB below peak output
40 dB (10 MHz, 18 MHz)

Spurious radiation: 40 dB below peak output

SSB carrier suppression: 40 dB

Undesired sideband suppression: at least 50 dB below peak output at 1.5 kHz modulation

Audio response (SSB): < -6 dB from 400~ 2600 Hz

3rd-order IMD: -31 dB (typical) @ 100 watts PEP, 14.2 MHz

Microphone impedance: 500 ~ 600 Ω

Automatic Antenna Tuner Option

Impedance range: 16.7 ~ 150 Ω (unbalanced)

Frequency range: 160 ~ 10 m amateur bands

Matching time: < 30 secs.

Matched SWR: $< 1.4:1$

Receiver

Circuit type: superheterodyne

Intermediate frequencies: 1st: 70.455 MHz
2nd: 455 kHz, Notch 8.215 MHz

Sensitivity:

(for 10 dB S/N, 0 dB μ = 1 μ V, IPO off)

Frequency → Mode (BW) ↓	150-250 kHz	250-500 kHz	0.5-1.8 MHz	1.8-30 MHz	28-30 MHz
SSB, CW (2.4 kHz)	$< 5 \mu\text{V}$	$< 2 \mu\text{V}$	$< 1 \mu\text{V}$	$< 0.25 \mu\text{V}$	0.5 μV for 12 dB SINAD (FM)
AM (6 kHz BW, 400-Hz, 30% modulation)	$< 40 \mu\text{V}$	$< 16 \mu\text{V}$	$< 8 \mu\text{V}$	$< 1 \mu\text{V}$	

Selectivity (-6/-60 dB):

Modes	Min.	Max.
SSB, CW wide, AM narrow (w/o options)	2.2 kHz	4.2 kHz
CW narrow with XF-110C option	500 Hz	1.8 kHz
CW narrow with XF-110CN option	250 Hz	700 Hz
AM (wide)	6 kHz	18 kHz
FM (-6/-50 dB)	8 kHz	19 kHz

Squelch sensitivity(IPO off):

1.8 ~ 30 MHz (CW, SSB, AM): $< 2.0 \mu\text{V}$

28 ~ 30 MHz (FM): $< 0.32 \mu\text{V}$

IF rejection (1.8 ~ 30 MHz): 70 dB or better

Image rejection (1.8 ~ 30 MHz): 70 dB or better

IF Shift range: ± 1.2 kHz

IF Notch rejection: 30 dB or better

Clarifier tuning range/steps: ± 9.99 kHz/ 2.5 Hz
5 Hz or 10 Hz

Maximum audio power output:

at least 1.5 watts into 4 Ω with $< 10\%$ THD

Audio output impedance: 4 to 8 Ω

Specifications are subject to change, in the interest of technical improvement, without notice or obligation.

Accessories & Options

Supplied Accessories

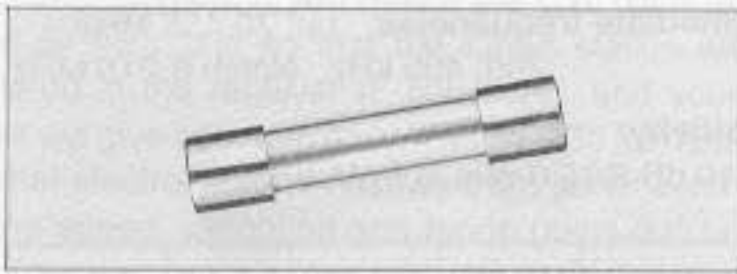

20-A Fuse (2 pcs, #Q0000009)

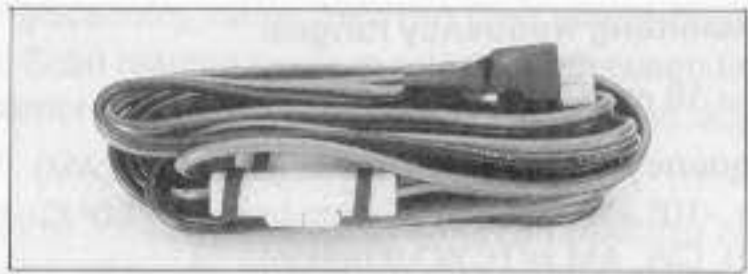

Fused DC Cable (1 pc, #T9018320)



3-ct Plug for KEY jack (1 pc, #P0090008)



2-ct RCA Plugs (2 pcs, #P0090544)



Hand Microphone MH-31A8J (1 pc)



3-ct Plug for DATA IN/OUT jack (1 pc, #P0091046)

Options

ATU-2 & FC-800 Automatic Antenna Tuners

The ATU-2 (internal) and FC-800 (external remote) match impedances of up to about 3:1 with the transmitter. Operation is controlled from the front panel. The FC-800 plugs into the rear panel, and can be mounted at the antenna feedpoint to avoid feedline losses.

TCXO-3 Master Reference Oscillator

For special applications and environments where extra frequency stability is essential, the TCXO-3 temperature-compensated crystal oscillator is a ± 2 -ppm (from 0° to +50° C) replacement for the reference oscillator.

YSK-900 Separation Kit

To separate the front sub-panel and mount the transceiver body in an out-of-the-way location, the YSK-900 includes a 6-meter length of interface cable and quick-release panel clamp which can be attached to the vehicle dash or a gooseneck-type mounting arm (not supplied).



ATU-2 & FC-800



TCXO-3

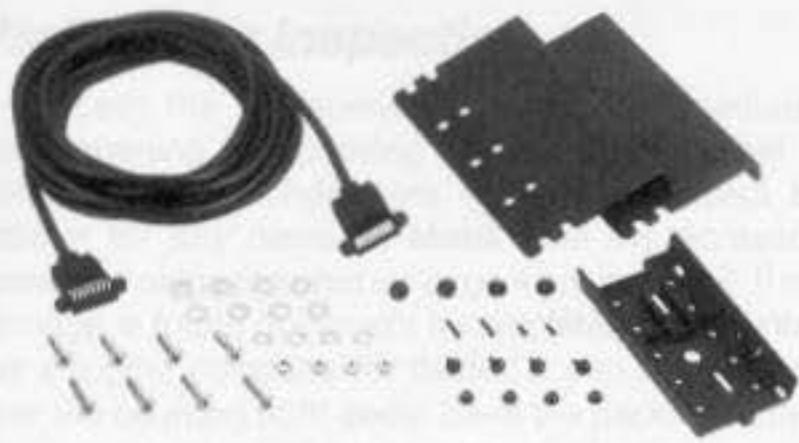

YSK-900

SP-6 Speaker w/Audio Filters & LL-5 Phone Patch Option

Selectable audio high- and lowpass filters with a large loudspeaker complement the audio characteristics of the FT-900 with your choice of 12 different audio filtering combinations. Two input terminals are provided for multiple transceivers, with a front panel switch to select between them. A phone jack is provided on the front panel to take advantage of the audio filters with headphones.



SP-6

With the optional LL-5 Phone Patch Unit installed in the SP-6, the FT-900 can be patched to the public network. The LL-5 includes a hybrid transformer circuit to assure proper impedance matches, and gain controls and level meter to set proper audio levels on the telephone line

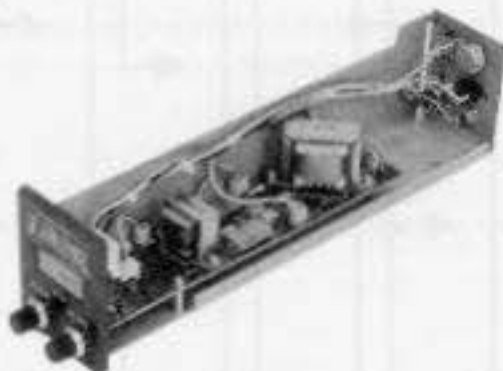

LL-5

DVS-2 Digital Voice System

Use as a continuous receiver recorder for instant push-button playback, or microphone audio recorder for multiple on-air playback, the DVS-2 applies the advantage of random-access solid state digital memory to serious communications. All data is stored electronically, with no moving parts except your finger and a push-button. More information is on page 34.



DVS-2

FIF-232C CAT System Interface

To control your FT-900 from an RS-232C serial port of an external personal computer, the FIF-232C converts the TTL levels required by the FT-900 to the RS-232C levels required by the computer. A cable is included to connect the FT-900 to the FIF-232C (the cable to the computer must be provided separately). The FIF-232C includes its own AC power supply.



FIF-232C

IF Crystal Filter Options

For extra CW receiver selectivity, the 500-Hz XF-110C or 250-Hz XF-110CN 8-pole crystal filter may be installed in the 455-kHz 2nd IF of the FT-900.

Also, for enhanced SSB and AM narrow receiver fidelity and ultimate attenuation, the XF-110S 8-pole, 2.6-kHz crystal filter may be installed in place of the standard ceramic filter.



Optional Filters

English

Microphones

Matching the electrical and cosmetic features of the FT-900, the MH-31_{A&J} Hand Mic has 600- Ω impedance, and include up/down and fast scanning buttons and a two-position tone selector.

The MD-1_{C8} Desktop Microphone may be used with the FT-900. However, it requires the optional CT-20 Microphone Cable. The CT-20 adapts the 8-pin mic. jack on the MD-1_{C8} to the 8-pin modular-style plug used with the FT-900.

Station Installation

Preliminary Inspection

Inspect the transceiver thoroughly immediately upon opening the packing carton. Confirm that all controls and switches work freely, and inspect the cabinet for any damage. Make sure the accessory fuses and plugs pictured on page 4 are included. If any damage is found document it completely, and contact the shipping company (or dealer, if you purchased it over the counter) right away. Save the packing materials in case you need to return the set for service.

If you purchased optional internal accessories separately, install them as described in *Installing Internal Accessories* (p. 37). This chapter describes base station installation first, followed by mobile installation and then interconnections with external accessories.

Installing the Front Sub-Panel

From the factory, the removable front sub-panel is packaged separately. Install the sub-panel by placing it into the upper receptacle on the front of the transceiver (it should rest flush with the front panel, and shifted approx 1 cm to the right of center). Next, using your left hand to keep the unit in place, slide the sub-panel to the left with your right hand. You will hear a click when the panel locks into place.

To remove the sub-panel, press the latch on the right side of the main front panel and slide the sub-panel to the right and out from the transceiver.

Important! Ensure the power is first switched off before removing the front sub-panel.



Installing the Front Sub-Panel



Removing the Front Sub-Panel

Changing the AC Voltage Range of the FP-800 Power Supply

- Disconnect the AC cable from the rear of the FP-800, and the DC cable from the FT-900.
- Remove the 8 screws affixing the top cover.
- Unsolder the wires from the transformer, and resolder for the required voltage as indicated below.
- Replace the fuse in the rear panel holder with a fast-blow, 8-A fuse (for 100 - 117-V AC) or 4-A (for 200 - 234-V AC).
- Check your work carefully, then replace the top cover and its 8 screws. Change the voltage marking on the FP-800 rear panel label, and replace the AC cord, if necessary.

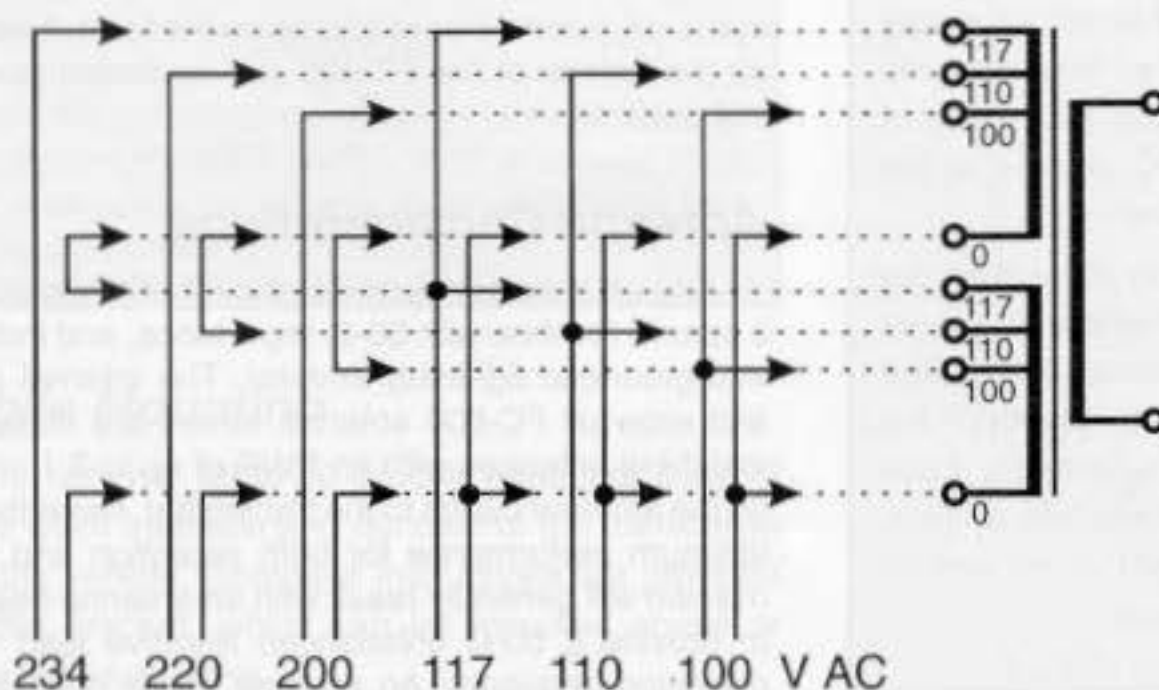

Important!

If you change the AC voltage range you must change the fuse in the rear panel holder. Do not use a slow-blow fuse. Also make sure to change the voltage marking on the label on the rear panel to match the new voltage setting.

AC Power Supply

The FT-900 is designed for operation from 13.5-V DC, negative ground. For base station installations, we recommend the matching Yaesu FP-800 AC power supply which was specifically designed for this purpose, and which includes a large loudspeaker for the transceiver and its own cooling fan. You can use another DC source capable of providing 20 amperes at 13.5-V DC with the supplied DC cable assembly, but you must be extremely careful to avoid reversed polarity connection. See the *Caution* box below.

If you are connecting the FP-800 with the FT-900, before connecting power, check the label on the rear of the FP-800 which indicates the AC mains voltage range for which the supply is currently set. If your AC mains voltage is outside of this range, the transformer taps inside the power supply must be rewired, and the fuse in the FP-800 must be changed. This involves some soldering of the AC mains input (see previous page, bottom), so you should ask your dealer for assistance if you are not experienced with this sort of work. *Incorrect connections could cause serious damage not covered by the warranty.*

In any case, make sure the power supply is set correctly before connecting power. If you have any doubts about the procedure, ask your dealer for help.

Also make sure the fuse in the FP-800 rear panel fuse holder is correct for your mains voltage:

AC Mains Voltage	Fuse Capacity
100 ~ 117	8 A
200 ~ 234	4 A

After making certain the AC voltage for which the power supply is set matches your mains voltage, and that the correct fuse is installed in the fuse holder, connect the DC cable from the power supply to the jack on the rear panel. Don't plug the power supply cord into the wall until all other transceiver interconnections have been made.

Caution!

Permanent damage can result if improper supply voltage is applied to the transceiver. Your warranty does not cover damage caused by application of AC, reversed polarity DC, or DC outside of the specified range of 13.5 V \pm 10%.

If you wish to use a power supply other than the FP-800, you must make certain that the DC supply connector to the transceiver matches the FT-900 requirements. See the DC connector pinout on the rear panel fold-out. Other manufacturers have power supplies with a physically matched connector that is wired differently: this will cause serious damage to the FT-900.

Transceiver Location

To assure long life of the components, make sure to provide adequate ventilation around the cabinet. The cooling system of the FT-900 must be free to draw cool air in at the bottom rear of the transceiver, and to expel warm air out of the upper rear panel. Do not place the transceiver on top of another heat-generating device such as a linear amplifier, and do not place equipment, books or papers on top of the transceiver. Place the transceiver on a hard, flat surface. Avoid heating vents and window locations that could expose the transceiver to excessive direct sunlight, especially in hot climates.

In addition to the above, if you choose to separate the front sub-panel and mount the transceiver body in a remote location, choose both mounting locations carefully. If mounting the main body in the trunk of a vehicle, ensure a stable flat surface capable of supporting the weight of the transceiver is available for the mounting bracket. Do not mount the transceiver into fiberboard, plastic or other materials sometime used in automotive construction. Find a location that permits mounting the bracket bolts through rigid sheet metal, such as the transmission hump or trunk structural support members. The front sub-panel is lightweight, and can be mounted almost anywhere on the dashboard, but as stated before, avoid areas where it might be exposed to direct heat and sunlight.

Grounding

For protection from shock and proper performance, connect the **GND** terminal on the rear panel to a good earth ground, using a heavy braided cable of the shortest length possible. **Warning!! Do not use gas line for station grounding!** All other station equipment should be connected to the same grounding cable, as close together as practical. If you use a computer with or near the FT-900, you may need to experiment with grounding of both the transceiver and the computer to suppress computer noise in the receiver.

Adjusting the Front Panel Angle

If your installation places the FT-900 much below eye level, you may want to prop up the front. A wire bail on the bottom of the FT-900 can be folded down for this purpose.

Antenna Considerations

Any antenna connected to the FT-900 should have a coaxial feedline with 50- Ω impedance, and include a well-grounded lightning arrestor. The internal ATU-2 and external FC-800 antenna tuners are capable of matching antennas with an SWR of up to 3:1 or more on the amateur bands to the transmitter. Nevertheless, optimum performance for both reception and transmission will generally result with an antenna designed to provide a 50- Ω unbalanced resistive load at the operating frequency. An antenna that is not resonant

at the operating frequency may present too high an SWR for proper matching with the antenna tuner, in which case the antenna should be readjusted, or a wide-range manual antenna tuner should be used. If the tuner is unable to bring the SWR down to an acceptable level, attempting to transmit will result in an automatic reduction in power output and increased losses in the feedline. Operation under such conditions can waste power and cause TVI, RFI and RF feedback: it is better to install another antenna designed for that band. Also, if your antenna has a balanced feedpoint and you use a balanced feedline, install a balun transformer between the feedline and the transceiver's antenna jack.

Mobile Power Connection

A fused (20-A) DC power cable for mobile installation is supplied with the transceiver. Please note the *Caution* at the beginning of this chapter before connecting power. Plan to connect the DC cable directly to the vehicle battery, rather than to the ignition or accessory circuitry. Route the cable as far away from ignition cables as possible, and then cut off any extra cable (from the battery end) to minimize voltage drop losses. If the cable is not long enough, use #12 AWG stranded, insulated wire to extend it, but no more than is necessary. Use the following procedure to connect the cable:

- Before connecting the cable, measure the voltage across the battery terminals with the engine running fast enough to show a charge. If above 15 volts, the automobile voltage regulator must be adjusted to reduce the charging voltage before proceeding.
- With the radio end of the cable unconnected, connect the RED cable lead to the POSITIVE battery terminal, and the BLACK lead to the NEGATIVE terminal. Make sure the battery terminal connections are tight, and remember to check them periodically for signs of loosening or corrosion.
- Make sure the **POWER** switch on the transceiver is off, and plug the DC cable into the 6-pin molex jack on the rear panel.

Caution!

*In mobile installations, check to ensure that the transceiver **POWER** switch is off whenever starting or stopping the engine, to avoid damage from switching transients.*

Mobile Mounting

The optional MMB-20 Mobile Mounting Bracket allows quick insertion and removal of the transceiver from the vehicle. Complete instructions are provided with the bracket, which can be mounted above or below the transceiver.

Remote Mounting

The front sub-panel can be separated and the main unit and mounted remotely with the optional YSK-900 Separation Kit. Operation and mounting instructions are provided with the YSK-900.

Mobile Antenna Installation

Please review the Antenna Considerations on the previous page, as they apply equally to base and mobile antennas. Use the internal ATU-2 antenna tuner whenever possible in mobile installations, where the short antenna elements have very narrow bandwidth. Make sure that the shield of the antenna coax is firmly grounded to the car body at the antenna feedpoint if using a base-loaded vertical.

Interconnection of Accessories

The diagrams on the next page show interconnections of external accessories. If you have any questions on these accessories or connecting devices not shown, contact your dealer for advice.

Memory Backup

The **BACKUP** switch inside the hole at the front center of the bottom panel is turned on at the factory, allowing VFO and memory data to be retained while power is off. Backup current is miniscule, so it is not necessary to turn the **BACKUP** switch off except for long-term storage of the transceiver.

After about five years the transceiver may fail to retain memories (although operation will be otherwise unaffected), and the lithium battery should be replaced. Ask your dealer for replacement of the battery, or for instructions on how to do so yourself.

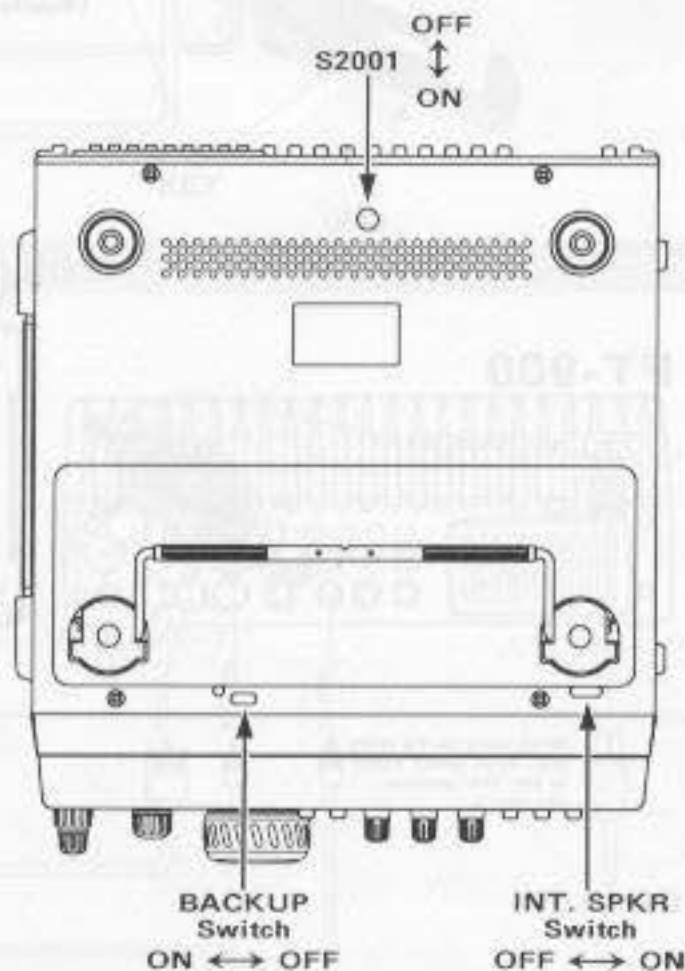

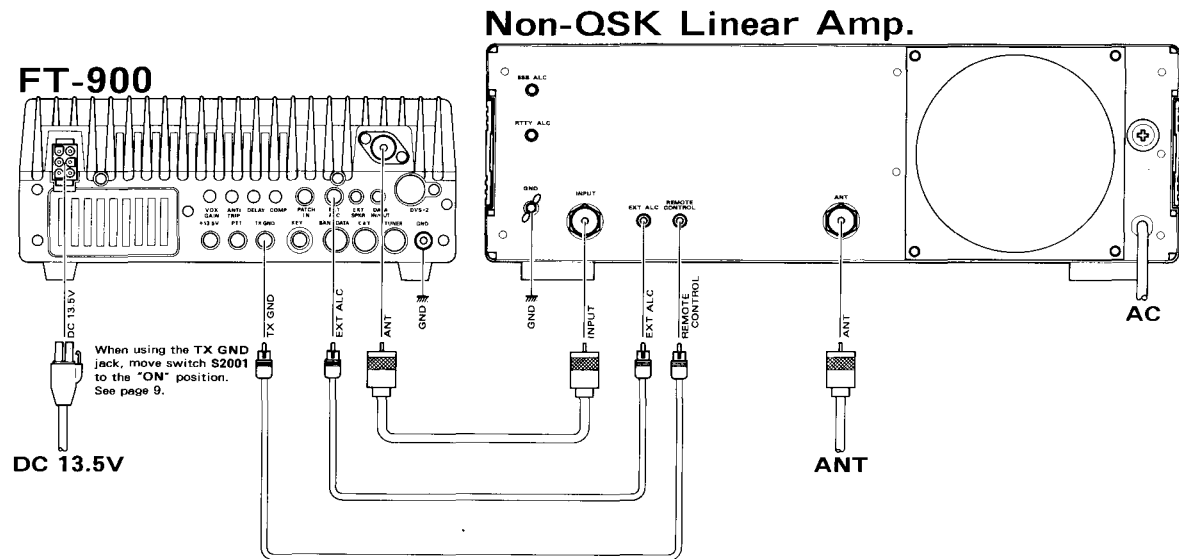
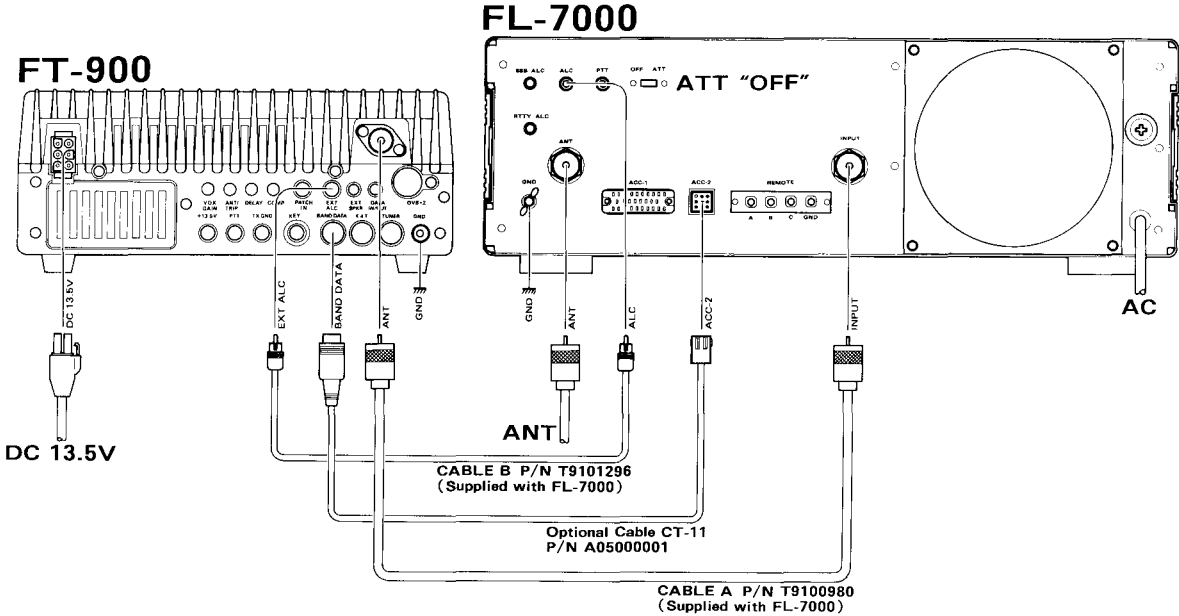
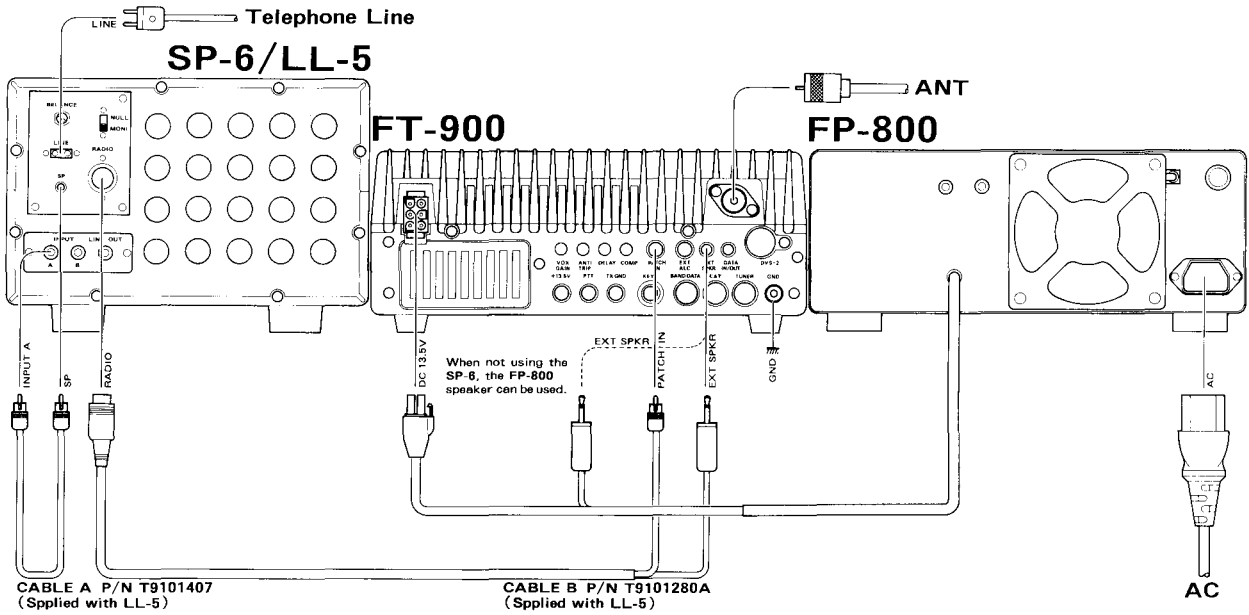

Switch Locations in Bottom Cover

Connecting External Accessories

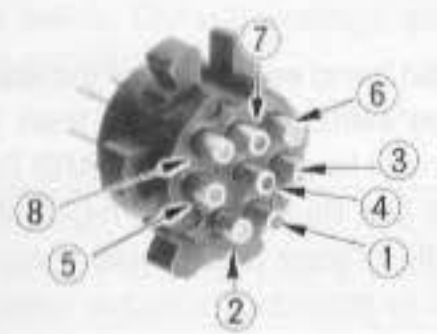
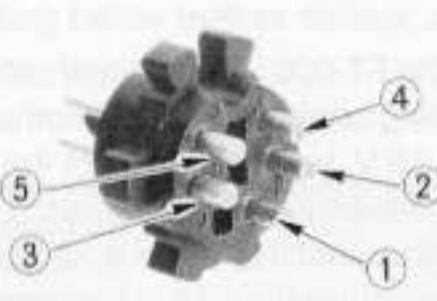
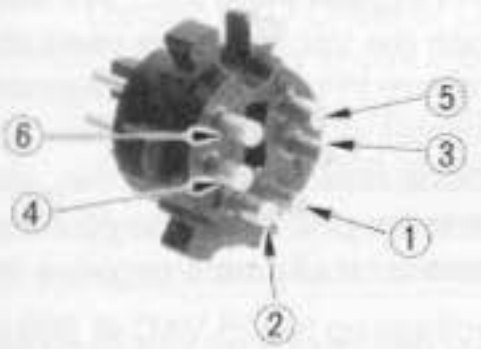
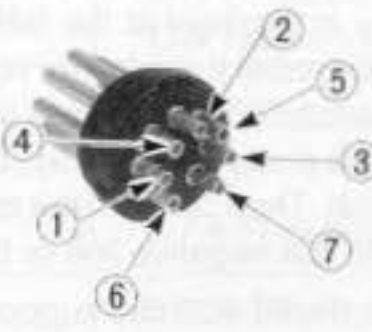
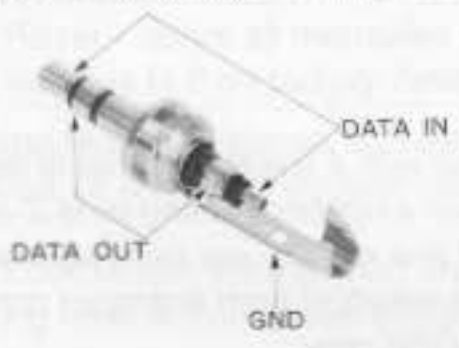
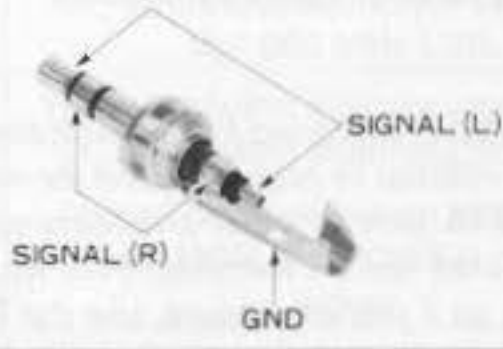

English

Connector Pinouts

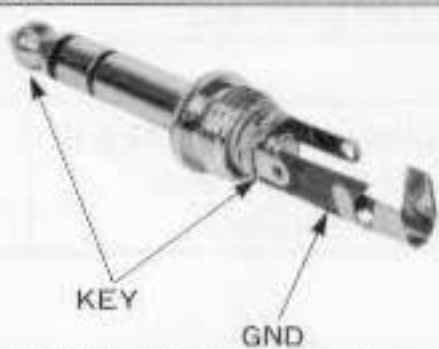
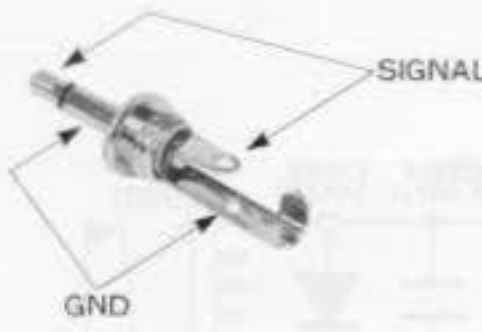
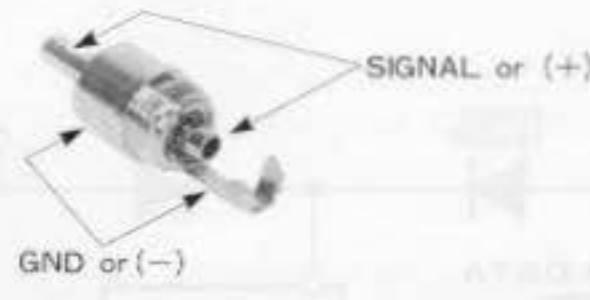
<p>BAND DATA</p>  <ul style="list-style-type: none"> ① +13V ② TX GND ③ GND ④ BAND DATA A ⑤ BAND DATA B ⑥ BAND DATA C ⑦ BAND DATA D ⑧ LINEAR 	<p>TUNER</p>  <ul style="list-style-type: none"> ① GND ② +13V ③ DATA ④ GND ⑤ GND BY FC-800
<p>CAT</p>  <ul style="list-style-type: none"> ① GND ② SERIAL OUT ③ SERIAL IN ④ PTT ⑤ S/PO ⑥ NC 	<p>DVS-2</p>  <ul style="list-style-type: none"> ① VOICE IN ② VOICE OUT ③ PTT ④ +9V ⑤ CNTL 1 ⑥ CNTL 2 ⑦ GND
<p>DATA IN/OUT</p> 	<p>PHONES</p> 
<p>KEYER PADDLE</p> 	<p>STRAIGHT KEY</p> 
<p>EXT SPKR</p> 	<p>RCA PLUG</p> 

English

Connecting a Linear Amplifier

For all linear amplifiers, connect the ALC output from the linear to the **EXT ALC** jack on the rear of the transceiver. After making the RF and t/r switching connections described below, you will probably need to adjust the ALC output level of the linear so that it is not overdriven by the FT-900. Your linear's manual should describe how to do this.

If using an FL-7000 with the FT-900, use optional cable CT-11 to provide automatic band selection for the linear, as well as QSK t/r switching control. If using another QSK linear, and if it can be switched with less than 100 mA of DC voltage below 15 V, you can connect the the t/r switch line for the linear to pin 2 of the **BAND DATA** jack, and the linear's exciter-enable output to pin 8 of the **BAND DATA** jack. This line must be held high (+5 to 15 V) to inhibit transmission until the linear is ready for excitation by the FT-900. If your QSK linear requires more than 100 mA or uses more than 15 V for t/r relay switching, you will have to provide a suitable external interface transistor, controlled by pin 2.

The FT-900 provides the **TX GND** jack on the rear panel, connected to an internal relay, for non-QSK t/r switching of linear amplifiers that use AC voltage, or DC voltage above 15 V, or require more than 100 mA for t/r switching. This relay is disabled at the factory to avoid the click sound when the transceiver is used alone or with a QSK linear. To enable the relay for non-QSK linears that exceed the above t/r switching requirements, you will need move switch S2001, located in the large hole near the rear center of the bottom cover, to its forward position (see the photo on page 9). Turn the FT-900 on its side or upside down and use a thin, sharp object to move the switch. Then connect the center contact of the **TX GND** jack to the positive line to your linear, and the outer contact to the negative line or the linear's chassis ground (if there is no separate negative line).

With the relay enabled, the FT-900 can support *non-QSK* linear t/r switching voltage up to 125 VAC @ 200 mA, or DC voltage up to 220 V @ 300 mA, or closed-circuit current up to 2 A with DC voltage up to 30 V. Use the **TX GND** jack after setting S2001 to the forward (on) position. *Do not attempt QSK operation with a linear if its switching requires the relay enabled.*

Caution!

*The FT-900 is designed for use with the FL-7000 when QSK operation with a linear amplifier is required, and with the internal t/r relay enabled for non-QSK operation with all other amplifiers. Using pins 2 and 8 of the **BAND DATA** jack for other amplifiers will not work unless the control line signals are carefully matched, and damage may result otherwise. Your warranty does not cover damage resulting from improper connections to this jack, so if you are unsure, use the **TX GND** jack and operate non-QSK only.*

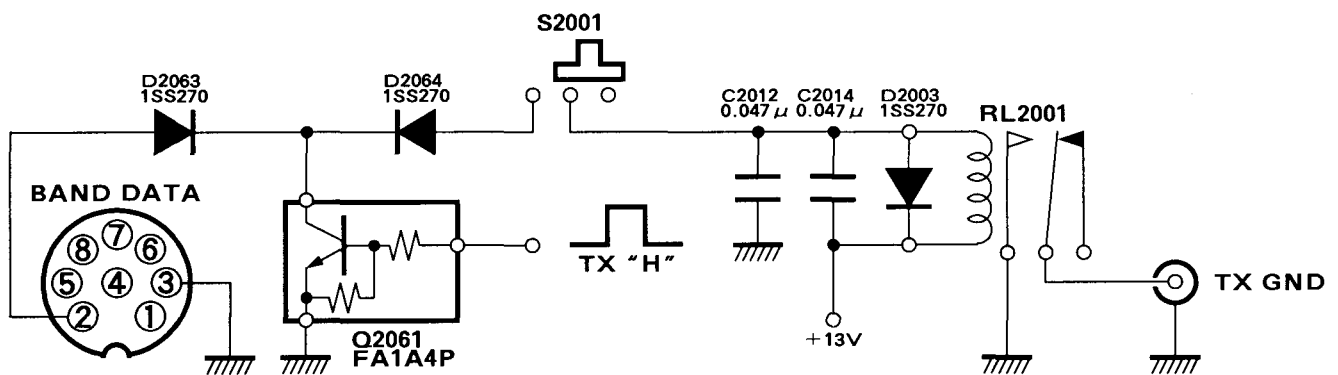

Linear Amp T/R Switching in the FT-900

English

Power-Up Customization & Button Combination Settings

By pressing and holding certain buttons while switching on the FT-900, you can make many settings to customize features to your particular requirements, and perform several troubleshooting functions. Some important settings can also be selected by holding the **FAST** button while pressing certain other buttons. These are described in the tables below. Default settings are in *italics*. To return the setting below to their default, simply repeat the power + button sequence.

Power-Up Functions	Hold this button & turn on	Comments
Panel Button Beeper <i>Enable/Disable</i>	NOTCH	Press a button to see if the beeper is enabled.
Display <i>BFO Offset</i> or Carrier Frequency in CW mode	▼DOWN	BFO Offset adds 700 Hz to displayed CW frequency. Affects display only.
<i>Enable/disable</i> 10-Hz frequency digit at right end of display	▲UP	Affects display only.
Make FAST Button operation <i>toggle on-off, or momentary</i>	FAST	FAST is displayed when active.
Adjust Repeater Shift (0 to 500 kHz, <i>100 kHz default</i>). Press FM again after setting.	FM	Shift is displayed. Use tuning knob or ▼DOWN/▲UP buttons to change in 1-kHz steps.
System Reset - clears all memories and returns settings to their factory default.	▲UP + ▼DOWN	VFOs and Memory 1 default to 7.000 MHz LSB.
Scan Resume Mode: Resumes scanning after 5-sec pause, or <i>only after squelch closes</i> .	V/M	There is always a pause after squelch closes before scanning resumes.
Select Lock Mode: <i>Tuning knob only, or tuning knob & front panel buttons</i>	LOCK	" LOCK " displayed when buttons are locked. MOX and POWER cannot be locked.
<i>Display/hide</i> Memory Channel display during VFO operation.	V ► M	Hides memory channel display when operating from a VFO.
<i>Display/hide</i> clarifier receiver offset	CLAR	
<i>Enable/Disable</i> Meter Peak-Hold Feature	METER	S & PO segments hold on peak signal level (tx or rx) for 1-second. Default setting is off.

Use the **▼DOWN** and **▲UP** buttons (to the right of the tuning knob) to select a valid frequency. The display is designed to show buttons have different functions.

By default, the new display mode, when receiving on a VFO, then also shows one band name in another. Changing bands allows the receiver frequency automatically, so that **RECEIVING** always return you to the frequency set and you can band (2.7 to 30 MHz) range of the band band. The 10-digit band has two 3-MHz band bands.

If the **HAM/POK** button has been pressed (to activate General coverage band mode), **GEN** appears in the upper left of the display and the **▼DOWN/▲UP** buttons step in 100-kHz increments.

Turn around the band dial with the tuning knob to get the top of a band if you want to equal the unique, see page 24. For fast-tuning steps, press the **FAST** button at the lower right of the knob, to enable the "320" indicator on the display.

Use **FAST** button correctly to press holding the button while tuning, but **FAST** will work while switching the **FT-900** into the **band** buttons, a **toggle** (press-on/press-off).



Station Installation

FAST Button Combinations	Hold FAST button and press...	Comments
Set Beeper Audio Frequency (300 to 3000 Hz, 880 default). Press NOTCH again when done.	NOTCH	Repeating double beep sounds and beep frequency displayed in Hz while adjusting.
Scan speed adjust	NB	Speed range adjustable from 1 - 200 msec. (10 default)
Main tuning knob step selection:	AM	toggle 2.5-, 5- or 10-Hz steps
Speech Processor IF Offset Adjust (-300~+500 Hz). Must be in an SSB mode. Press PROC again when done.	PROC	Offset affects both USB & LSB. Monitor your signal in an external receiver while adjusting.
Display/Select CTCSS Tone Frequency (from standard tones, default 88.5 Hz). Press FM again when done.	FM	Displays tone frequency in Hz. Use the tuning knob or ▼DOWN/UP▲ buttons to select.
Toggle Current Memory to be skipped when Memory Scanning (skip/no-skip)	V/M	Affects only memory scanning. "SCAN" no longer displayed for selected memory when activated.
CLAR control tuning step selection	CLAR	toggle 2.5-, 5- or 10-Hz steps
Lock main unit keys when front panel is separated for remote mounting	LOCK	Use tuning knob or ▼DOWN/UP▲ buttons to toggle "SEF-ON" or "SEF-OFF".
Change CW Offset & Sidetone	ATT	select 400 - 1000 Hz (700 Hz default)
Toggle internal keyer CW weighting	IPO	Use the ▼DOWN/UP▲ buttons or tuning knob to select. "ON" = 1:1:4.5, or "OFF" = 1:1:3 (default).
Reverse CW Sideband	CW	Select <i>USB</i> (default) or <i>LSB</i>

Operation

Getting Started Tutorial

While reading this chapter, refer to the fold-out photos of the panels for the locations and functions of the controls and jacks.

Before plugging in the transceiver the first time:

- ✓ Make sure your supply voltage is correct.
- ✓ Ensure a proper ground connection.
- ✓ Connect an antenna as described in the *Installation* chapter.

Then preset the following controls:

MOX & VOX switches: off (■);
MIC GAIN, RF PWR and **SQL**: all ccw (minimum);
PROC, NB, IPO, ATT: all off;
AF: 10 o'clock;
SHIFT and **NOTCH**: 12 o'clock.

Connect your microphone and/or CW key or paddles, then press the **POWER** switch. The display should light up. If not, recheck all connections. At the left side of the panel, if the green LEDs in any of the **PROC, NB, ATT** or **IPO** buttons are on, press to turn them off.

Take a moment to study the LCD, the FT-900 combines frequency, operational settings and a multi-function meter into one easy-to-read display. You should see "VFO-A" or "VFO-B" at the left, with the operating frequency in large digits in the center (if you don't see a VFO indicator, press the **V/M** button near the top right). At the right side of the display is a small 2-digit memory channel number (□ / by default).



Use the **▼DOWN** and **UP▲** buttons (to the right of the tuning knob) to select a band for which your antenna is designed. These buttons have different functions:

- By default (the *ham stepping* mode), when receiving on a VFO, these step from one ham band to another. Changing bands stores the current frequency automatically, so that **▼DOWN/UP▲** always return you to the frequency last used on each band (if it is inside the 500-kHz range of the ham band). The 10-meter band has two 1-MHz ham bands.
- If the **HAM/GEN** button has been pressed (to activate *GENeral coverage tuning* mode), "GEN" appears in the upper left of the display, and the **▼DOWN/UP▲** buttons step in 100-kHz incre-

Amateur Bands

Meter Band	Frequency Range (MHz)
160	1.800 ~ 2.000
80	3.500 ~ 4.000
40	7.000 ~ 7.500
30	10.000 ~ 10.500
20	14.000 ~ 14.500
17	18.000 ~ 18.500
15	21.000 ~ 21.500
12	24.500 ~ 25.000
10*	28.000 ~ 29.700 (in two 1-MHz segments)

ments (or 1-MHz if **FAST** tuning is activated, as described later).

Example: say you're tuned to 7.000 MHz, and want to change to 21.200 MHz.

- First check to see if the "GEN" appears in the display, and if it does, press the **HAM/GEN** button. Then press the **UP▲** button 4 times to change to the last-used frequency on the 15-meter band.
- Now you can use the tuning knob to tune to 21.200. However, if the current frequency is more than 100 kHz away, you can save some cranking: press **HAM/GEN** again so that "GEN" appears, and press the **▼DOWN/UP▲** buttons, as needed, to get within 100 kHz. Then use the tuning knob. When you want to change bands again, remember to press **HAM/GEN** so that "GEN" disappears.

Press the mode button (to the left of the tuning knob) corresponding to the mode you wish to operate. For now, we suggest an SSB mode: USB for amateur bands above 10 MHz, or LSB otherwise. Indicators at the top of the display confirm your selection.

Adjust the **AF** control for comfortable volume on signals or noise in the loudspeaker or headphones. Tune around the band a bit with the tuning knob to get the feel of it (if you want to adjust the torque, see page 24). For faster tuning steps, press the **FAST** button at the lower left side of the knob, to enable the "FAST" indicator on the display.

- ☞ Fast tuning normally requires *holding* this button while tuning, but if you hold it while switching the FT-900 on, the button becomes a *toggle-type* (press-on/press-off).

Hiding the 10-Hz Frequency Digit

If you prefer to have the 10-Hz digit hidden on the frequency display, you can turn it off by holding the **UP▲** button while switching on the transceiver. Tuning steps are not affected. Repeat the process to return the 10-Hz digit display.

If your microphone has **UP** and **DWN** buttons, you can use them to tune in the same steps as the tuning knob. Also, the **FST** button on the microphone duplicates the **FAST** button on the front panel.

Using the Keypad for Direct Band Selection & Frequency Entry

The 10-digit front panel keypad permits the following operation:

- Instant amateur band selection
- Direct numeric frequency entry
- An "instant-recall" programmable general coverage band



FT-900 Instant Band Recall & Direct Entry Keypad

To select an amateur band at any time, simply press the numeric key corresponding to the desired band (notice the label at the upper left of each key). The lower band limit for each amateur band is pre-programmed for the corresponding button.

- For example, if you are operating on 18 MHz and want to quickly QSY to 160 meters (without having to press the **▼DOWN/UP▲** buttons five times), simply touch the **18** key.
- You can also enter frequencies directly, and save a lot of time cranking the tuning knob and toggling the **FAST** button. Let's say you're at the low end of 10 meters (28.035 MHz, for example), and want to QSY up to 28.600 MHz to check in on a net. You can get there quickly by pressing:

ENT → **3.5** → **24.5** → **18** → **ENT**.

First pressing **ENT** causes the frequency display to clear except for the bottom segments and the two decimal points. At this point you can enter all digits of the frequency. After the last digit, the receiver will QSY automatically. Or you can enter just the first few digits then press **ENT** momentarily (< 1/2 sec.), in which case zero replaces the remaining digits.

Note: For frequencies below 10 MHz, you can either enter a leading 0, or else enter a decimal point (press the **GEN** button) after the MHz digit. For frequencies below 1 MHz, enter two leading zeros, or enter the decimal point first.

- **Ex.** Enter the frequency of your favorite AM broadcast station on 648 kHz. There are two ways you can do this:

Selecting Tuning Step Size

Tuning speed using the dial knob or microphone **UP/DWN** keys depends on the default tuning step size for each operating mode, and if the **FAST** tuning function (button) is engaged.

You can select 2.5-, 5-(default) or 10-Hz tuning steps by holding the **FAST** button and then pressing **AM**, the frequency display clears and shows the selected tuning steps. Rotate the tuning knob or use the front panel **▼DOWN/UP▲** buttons to select the desired size, then press **AM** again to return to normal. Note: while tuning increments as small as 2.5 Hz are possible, maximum display resolution is 10-Hz.

For digital modes, 2.5- and 5.0-Hz steps offer a slower tuning rate and finer resolution for tuning Packet, PACTOR, AMTOR and RTTY. Pressing the **FAST** button increases the default tuning rate (**FAST** appears in the display). Possible combinations are:

	AM / FM	USB/LSB/CW
Normal	100 Hz	2.5/5/10 Hz
Fast	1 kHz	100 Hz
Clarifier	2.5/5/10-Hz steps, ±9.99 kHz range	

Similarly, **CLAR** tuning steps can also be selected. Hold the **FAST** button and then press **CLAR**. Select the desired step size, then press **CLAR** again to finish. Maximum receiver offset available from the clarifier is ±9.99 kHz, regardless of step size.

ENT → **GEN** → **18** → **6** → **10** → **4** → **24.5** → **8** → **ENT**

or

ENT → **29** → **0** → **29** → **0** → **18** → **6** → **10** → **4** → **24.5** → **8** → **ENT**.

With keypad frequency entry, operation not only immediately shifts to the newly entered frequency, but the entry is also automatically written into the front VFO for that amateur band. Non-amateur frequencies are written into the GEN register (covered next).

The **GEN** key at the bottom right is used to store and select a "general purpose" band. While numeric keys 1-0 are pre-programmed with amateur bands, any frequency (amateur or general coverage) can be recalled from the GEN band. You might want to program the the bottom edge of the AM broadcast band (540 kHz) for example, if you enjoy listening to music, sports or news.

Meter Functions

The FT-900 incorporates a multi-function digital bargraph meter with "peak-hold" segments for receive signal strength and transmitter power output to aid in tuning and adjustments. This feature is off by default, and is activated by holding the **METER** button depressed while turning the transceiver on.

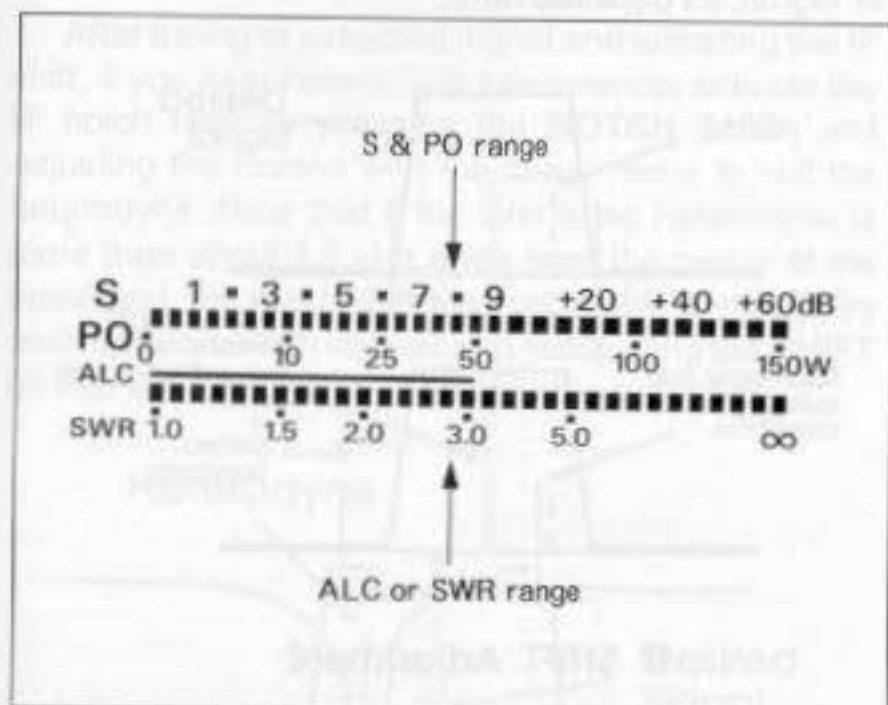

FT-900 Multi-Display Meter

Three meter display combinations can be toggled by pressing the **METER** button:

1. RX S-Units & TX Power Output
2. RX S-Units, TX Power Output & ALC range
3. RX S-Units, TX Power Output & SWR

In receive, the bargraph segments respond to relative signal strength (in S-units) of stations. The "peak-hold" circuitry keeps the rightmost segment on for a delay of 1 second, indicating maximum signal strength. This effect is useful in tuning stations with rapidly varying signal strength, and simplifies tuning AM broadcast stations.

Dial & Panel Locking Schemes

Pressing **LOCK** normally only disables the tuning knob (it still turns, but does not tune). To have the **LOCK** button also disable the front panel buttons (except **MOX**, **VOX**, **AGC-F**, **KEYER** & **BK-IN**), hold it while switching the transceiver on.

Also, if you separate and remote-mount the front sub-panel, you may want to disable the direct-entry keypad on the Main Unit to prevent inadvertent operation from loose items (or children's fingers!). Hold the **FAST** button and press **LOCK** to toggle "SE P - ON" (locked) and "SE P - OFF" (unlocked).

General Coverage Reception

You may have noticed that you can tune outside the amateur bands in either the GEN or HAM tuning modes. However, the transmitter only operates inside the 500-kHz segments containing the amateur bands. If you try to transmit out of band, the **TRANSMIT** LED still turns red, but there is no RF power output.

Also, the ham band recall system ignores such frequencies. If you select a ham band and then tune outside the band, the non-ham frequency will be lost when you change bands. When you return to the original band you will find that it has reverted to the (ham-band) frequency it was on when that band was previously selected.

Don't let this worry you: any displayed frequency can always be stored in a memory (as described on page 26) so you can recall it quickly later. Once you become familiar with the memories, you will find this convenient: each memory can be tuned just like a pair of VFOs, and stored again without having to go through the VFOs. In addition to the above, general coverage reception provides all the features available on ham frequencies.

Popular Shortwave Broadcast Bands

Meter Band	Freq. (MHz)	Meter Band	Freq. (MHz)
LW	.150-.285	31	9.35-9.90
MW	.520-1.625	25	11.55-12.05
120	2.30-2.50	22	13.60-13.90
90	3.20-3.40	19	15.10-15.70
75	3.90-4.00	16	17.55-17.90
60	4.75-5.20	-	18.90-19.30
49	5.85-6.20	13	21.45-21.85
41	7.10-7.50	11	25.67-26.10

Dealing with Interference

The FT-900 includes special features to suppress the many types of interference that may be encountered on the HF bands. Using these controls effectively requires familiarity with the types of interference and the subtle effects of some controls. Therefore the following information should be considered only as general guidelines for typical situations, and as a starting point for your own experimentation.

The controls are described in the order that you would usually adjust them after changing bands. An exception to this is if strong pulse noise is present, such as from man-made interference, in which case you may need to activate the noise blanker (described on the next page) before making other adjustments.

Front End Selections: RF Amp (IPO) & ATTenuation



A constant-gain, parallel FET RF amplifier receiver front end provides high sensitivity to weak signals. This amplifier is active whenever the **IPO** (*Intercept Point Optimization*) button is *OFF*, and bypassed when it is on. Additionally, a 12-dB attenuator in front of the RF amplifier can be activated by the **ATT** button.

When looking for weak signals on a quiet band you will want maximum sensitivity, so the **IPO** and **ATT** buttons should both be switched off. This situation is typical during quiet times on frequencies above 20 MHz, and when using a small antenna on other bands.

If you notice intermodulation from strong signals on other frequencies, turn on the IPO function to bypass the RF amplifier. Sensitivity is reduced slightly, but intermodulation immunity increases.

Even with the IPO function on, very strong signals can still overload the mixer. So if you still notice intermodulation, or if the signals you want to listen to are very strong, you can press the **ATT** button. This reduces the strength of all signals (and noise) by 12 dB, and can make reception more comfortable, important especially in long QSOs.

AGC Selection (Automatic Gain Control)

When tuning around the band looking for signals, the **AGC-F** button is usually best kept on (that is, depressed ) , so receiver gain recovers quickly after tuning past strong signals. Once you have a signal tuned in, unless it is very weak, you probably will find reception more comfortable with it off ( slow AGC).

NB Setting (Noise Blanker)

This circuit can blank both wide and narrow pulses, and can sometimes also reduce the level of static crashes from electrical storms. The **NB** button activates the blanker, and the LED remains lit while it is on. If you hear pulse noise, press the **NB** button so that it lights. If the blanker seems to distort the signal you're listening to, leave it off.

10-Hz Tuning in AM & FM Modes

When changing modes from SSB or CW to AM or FM, operation initially remains on the same frequency, even if it is not a multiple of 100 Hz (the default tuning step in AM/FM modes).

As soon as you attempt to tune, the operating frequency jumps up or down to the nearest whole 100-Hz step. However, the clarifier can be set to use 10-Hz steps in all modes, so if you need 10-Hz resolution in AM or FM mode, activate the clarifier (for a more detailed explanation, see page 25).

IF Shift Adjustment (not used in AM & FM modes)

Once you have tuned in a signal you are going to listen to for a while, if you hear interference from nearby frequencies, use the **SHIFT** control to suppress the interference. Turning the **SHIFT** control left or right from center shifts the center frequency lower or higher, as depicted here.

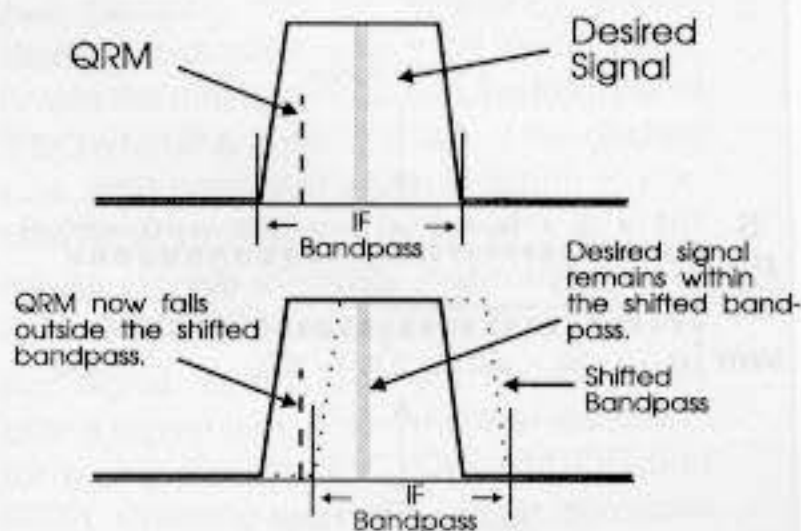

IF SHIFT Adjustment

You may want to press the **LOCK** button before adjusting the **SHIFT** control, as accidentally retuning would invalidate your setting (particularly in narrow-bandwidth CW). When ready to retune to a new frequency, press **LOCK** again to release it, and return the **SHIFT** control to its normal position (centered).

AM & CW Narrow IF filters

Pressing the **AM** mode button once (when switching from another mode) selects the default 100-Hz tuning steps and the 6-kHz AM wide bandwidth. This gives the highest fidelity, and is best on strong AM signals (and particularly music). For weaker AM signals, or where adjacent channel interference is present, the narrower 2.6-kHz IF bandwidth offers a compromise between interference rejection and fidelity. This can be selected by pressing the **AM** mode button a second time (**NAR** appears at the top of the display).

For even better reception of AM signals under these conditions, you can switch to SSB (whichever sideband gives the clearest reception). Along with the choice of the best sideband, you gain several benefits of the IF **SHIFT** control. After selecting LSB or USB, you need to zero beat the carrier to avoid distortion: turn the **SHIFT** control (outer collar) all the way clockwise for LSB or counterclockwise for USB, fine tune until the signal is steady, then return the **SHIFT** control to center (or for best audio and interference suppression).

Pressing the **CW** mode button once when switching from another mode selects the standard 2.6-kHz IF bandwidth also used for SSB. If you have either the 250-Hz or 500-Hz narrow IF filter installed, pressing the **CW** button again selects the narrow filter, and

"**WAB**" appears at the top of the display. The 2.6-kHz bandwidth is often convenient to give a "wide view" when tuning around, but once you find a signal of interest and center it in the passband, the narrow selection is much better. The next section on transmission gives more details of CW operation.

IF Notch Filter (not used in FM mode)

After tuning in a desired signal and adjusting the IF shift, if you hear heterodyne interference, activate the IF notch filter by pressing the **NOTCH** button and adjusting the control with the same name to null the heterodyne. Note that if the interfering heterodyne is more than about 1.2 kHz away from the center of the passband, the notch filter may be unable to null it. Try switching the notch filter off and readjusting the **SHIFT** so that the heterodyne is outside the passband.

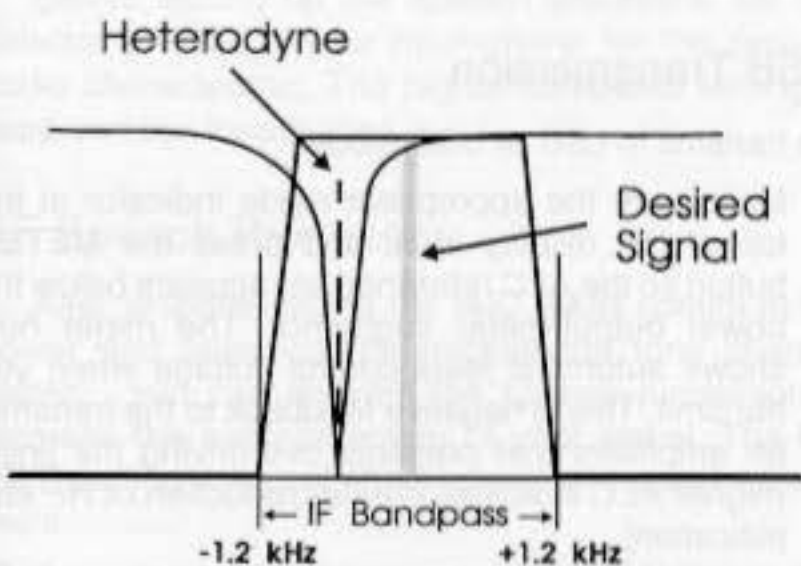

IF Notch Filter Adjustment

Adjusting Beeper Pitch

You can change the pitch of the beep that sounds when a front-panel button is pressed by holding the **FAST** button while pressing the **NOTCH** button/LED. The display shows the present beep frequency in Hz, while a double-beep annunciator repeats. Rotate the tuning knob to select a comfortable pitch from 300-3000 Hz (in 10-Hz steps), then press the **NOTCH** button/LED once again.

Note: Be careful not to confuse this adjustment with the BFO offset and CW sidetone pitch setting, as explained later on page 23.

Beeper volume is independent of the front panel AF gain setting, but is adjusted using a trimpot accessible via a hole at the rear left side panel of the transceiver. See the explanation and photograph in the box on page 22 (*Sidetone and Beeper Volume*).

XF-110S SSB Crystal Filter Option

The optional XF-110S crystal IF filter can be installed in place of the 2.6-kHz ceramic IF filter, to enhance SSB and AM narrow reception. While both filters have approximately the same shape factor and bandwidth, the crystal filter provides a flatter passband, giving receiver audio a more natural sound, and also deeper attenuation for better immunity to interference from nearby signals.

Typical plots of the two filters are superimposed below for comparison. Ask your dealer for the XF-110S option if you don't have it. Installation is described starting on page 37.



Transmitting

The FT-900 can transmit within the 500-kHz segments of the HF amateur bands above 1.8 MHz, and from 28 to 30 MHz. When tuned between 1.5 and 1.8 MHz, the tuner will not function, and when tuned to any other (general coverage) frequency, the transmitter is disabled. Still, you should restrict your transmissions to those frequencies authorized by your license, and for which your antenna is designed.

Attempting to transmit out of band still causes the red **TRANSMIT** LED above the tuning knob to light, but nothing is transmitted. The transmitter is also temporarily inhibited when stopping scanning (described later), as pressing the PTT switch while scanning just causes the scanner to stop.

When you transmit on an amateur band, the FT-900 senses reflected power at the antenna jack. If an impedance mismatch causes too much reflected power, the transmitter shuts down, and "**SWR**" appears near the bottom right corner of the display. Although this should prevent damage to the transceiver, we still recommend that you not transmit without having a proper antenna connected to the antenna jack.

Automatic Antenna Matching

The internal ATU-2 or external FC-800 automatic antenna tuner makes even first-time transmitter setup very simple. After using it once on a band, it recalls previous settings from memory (the tuner has 31 of its own) during reception, whenever you tune to the same part of the band again. When using the tuner the first time on an antenna, we recommend you set the **RF PWR** control to around the 9-o'clock position (or 12-o'clock above 24.5 MHz), to minimize possible interference to others and to minimize stress on the tuner, feedline and antenna (in case there is a high SWR). All you have to do beforehand is ensure your transmit frequency is clear of other signals. If you want to monitor the tuner's action, press the **METER** button twice until the SWR bargraph display appears. If **SPLIT** is displayed to the left of the frequency, press the **SPLIT** button to disable split operation for now.

After making sure you are on a valid transmitting frequency, and that the channel is clear of other signals, press and hold the **TUNER** button for ½ second. The "**TUNER**" and "**WAIT**" indicators appear on the display, indicating the automatic tuner is activated and tuning, and the **TRANSMIT** LED turns red for up to thirty seconds while the tuner seeks the proper matching settings. RF power is automatically reduced to 50 watts during the tuning process.

If monitoring SWR on the meter, you should see the tuner stop at the lowest SWR. When the **WAIT** indication disappears, you may transmit (assuming the **SWR** indicator didn't come on).

The **TUNER** indicator remains on (unless you press the **TUNER** button momentarily to switch the tuner

off). If the tuner found a match, the **WAIT** indicator will occasionally flash when you change frequency (while receiving), as the main microprocessor reports the frequency change to the tuner coprocessor (reception is unaffected). The tuner coprocessor compares the current frequency with its memories, and resets itself to the new range if it has any previously stored settings for that range. However, when you first connect a new antenna, the tuner does not have the correct settings stored in these memories, so you need to "train" the tuner, by pressing the **TUNER** button whenever you change to a new frequency range (for this antenna).

Remember, **TUNER** button action is twofold:

- pressing the button *momentarily* (< ½ sec.) toggles the ATU on (in-line) or off (bypassed).
- holding the button for ½ sec. or longer brings the tuner in-line *and* seeks a tuning match.

SSB Transmission

To transmit in LSB or USB mode:

- Make sure the appropriate mode indicator at the top of the display is lit, and press the **METER** button so the ALC reference bar appears below the power output-meter segments. The meter now shows automatic level control voltage when you transmit. This is negative feedback to the transmitter amplifiers that prevents overdriving the finals (higher ALC indicates greater reduction of RF amplification).
- If this is the first time you are transmitting SSB with the FT-900, preset the **MIC GAIN** control to about 12 o'clock, the **RF PWR** control fully clockwise, and make sure the **VOX** is off (■).
- Confirm that the display shows the frequency you want to transmit on.
- Listen carefully on the frequency to make sure you will not interfere with any other stations. Then, if you have an automatic antenna tuner option, press and hold **TUNER** to match the antenna.
- After **WAIT** disappears from the display, press the PTT (push-to-talk) switch on your microphone, and give your callsign (to identify your transmission) or make your call. You should see the meter segments fluctuate as you speak.

Note: Adjusting the **MIC GAIN** control for proper ALC indication on the meter requires the SWR be below 1.5:1. Otherwise the ALC meter may behave erratically.

Important!

If the **SWR** indicator appears at any time, *the tuner is unable to match your antenna to the transmitter at the displayed frequency.* You will have to tune to another frequency, or repair or replace your antenna or feedline.

- To find the optimum setting of the **MIC GAIN** control for your microphone, begin with it fully counterclockwise (minimum), and adjust it while the **RF PWR** control is fully clockwise. Speak into the microphone (at a normal level) and adjust it so that the meter segments stay within the solid band on the ALC scale during voice peaks. This will normally be about the 10-o'clock position with the MH-31A8J.
- You can adjust the **RF PWR** control for less output power if desired, as indicated on the meter scale. Use the lowest power output possible to maintain reliable communications — not only as a courtesy to other stations, but to minimize power consumption and the possibility of causing RFI and TVI, and to maximize the life of the equipment.

Microphone Tone Selection

Before setting up the speech processor, set the selector switch on your microphone for the desired audio characteristic. The higher-numbered setting(s) suppress low frequencies.

AF Speech Processor

After properly setting the **MIC GAIN** control at full power and selecting the microphone tone characteristic, you can activate the speech processor to increase the average power of your signal. The **RF PWR** setting does not affect speech processor adjustment.

- Press the **METER** button so that the ALC sub-display appears, and the **PROC** button just below and to the right of it, so that the LED in the button lights. Now speak into the microphone and adjust the **MIC GAIN** control slightly, if necessary, so the bargraph segments stay within the solid band on the ALC scale.
- The **COMP** control on the rear panel (the shaft nearest the antenna jack) sets the degree of compression. This control is preset to the 12-o'clock position at the factory, which provides about 10 dB of speech compression with an average voice pitch. Setting it for more compression *can seriously distort your signal*, so it should only be adjusted if you have some means of monitoring the transmitter. You can do this with an external receiver, if you have one, or by having another station give you signal reports as you adjust it.
- If you adjust the **COMP** control, recheck your **MIC GAIN** control setting as described above.

VOX (Voice-Actuated T/R Switching)

In VOX operation, your voice causes transmit/receive switching merely by speaking into the microphone, without having to press the PTT. For the VOX circuit to operate properly, three controls on the rear panel must be set to match your microphone and the acoustic environment of your station. Once set, these trimmers should not require readjustment unless you change your microphone or station location.

IF Processor Frequency Shift

The *frequency-shifted processor* in the FT-900 lets you shift the IF passband (and hence the RF passband as well) of your transmitted signal in the SSB mode, to customize your signal for your own voice characteristics.

To display the current transmitter offset, hold the **FAST** button and press **PROC**. The display changes to 3 frequency digits indicating the current offset in kHz. While this is displayed, the offset can be set between -0.30 (-300 Hz) and 0.50 ($+500$ Hz). A minus sign indicates the offset is closer to the carrier (low-frequency speech audio emphasized). You can transmit during the display and adjustment. When done, press **PROC** again to return the display to normal.

Of course you can adjust the offset by trial-and-error on the air, but it is better if you have a separate receiver in which you can hear the effect yourself. Otherwise, we recommend starting with $+0.10$ ($+100$ Hz) offset initially, to add some "crispness" to your processed speech.

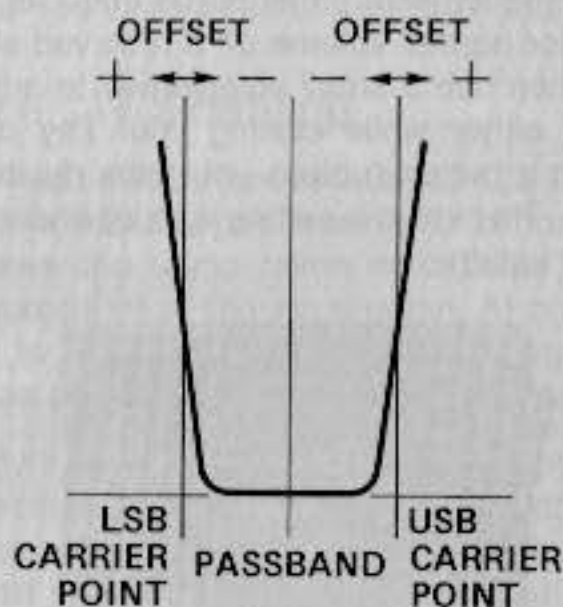

- First set the receiver for normal volume on a clear channel, and preset the **VOX GAIN** control (nearest the power jack on the rear panel) fully counterclockwise. Also preset the **ANTI-TRIP** and **DELAY** controls (next to the **VOX GAIN**) to mid-range.
- Set the **RF PWR** control fully counterclockwise (to avoid creating interference while setting the VOX controls), then press the **VOX** switch near the lower left corner of the front panel to activate VOX (—).
- Without pressing the PTT switch, speak continuously into the microphone while slowly advancing the **VOX GAIN** control clockwise (as viewed from the rear), just until your voice keys the transmitter.
- Speak intermittently into the microphone, and note the "hang time" between the moment you stop speaking and when the receiver is reactivated. This period should be just long enough so that the Tx

stays keyed between words, but switches to receive during pauses. Adjust the **DELAY** control, if necessary, for a comfortable hang time.

Note: the **DELAY** setting also controls hang time for CW *semi-break-in* operation, covered next.

The **ANTI-TRIP** control probably needs no adjustment, but if receiver audio from the loudspeaker trips the transmitter with the microphone in its normal operating position, adjust the **ANTI-TRIP** control more clockwise (as viewed from the rear). On the other hand, if VOX keying seems sluggish or unstable when you speak into the microphone, try a more counter-clockwise setting.

Note: if VOX operation is found to be unstable when the **RF PWR** setting is increased, RF feedback from the antenna or feedline may be getting back into the transmitter. Be sure that your antenna is properly matched, and that your antenna or feedline is not radiating near the transceiver.

Sidetone & Beeper Volume

The CW sidetone and front panel beeper volume is adjusted by the trimmer accessible through a hole on the left side-panel of the unit. Set the **AF** control for normal volume on a received signal or noise, then use a small screwdriver to adjust the trimmer either while closing your key or while pressing a button (unless you have disabled the beeper). This volume setting is independent of the receiver volume.

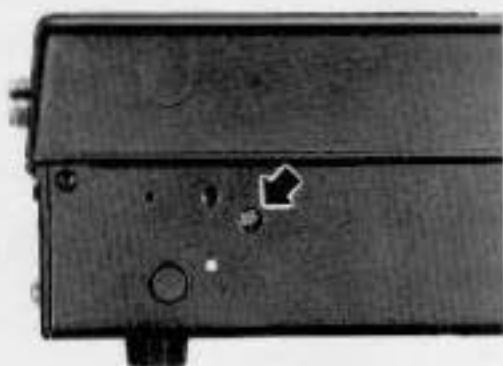

Trimmer Adjustment

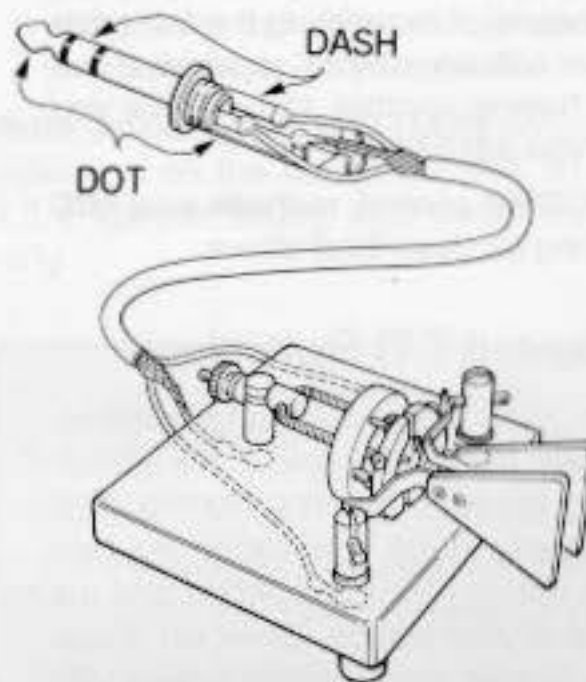
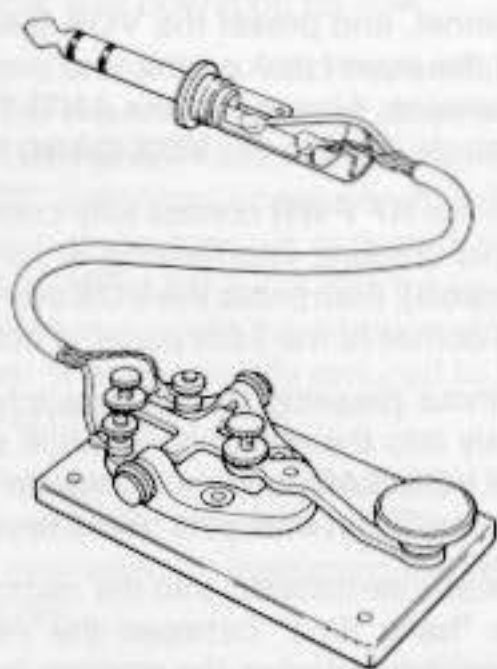

CW Straight Key or Paddle Connections

CW Transmission

There are several types of CW transmission available with the FT-900. All require, of course, that you have a CW key or paddles connected to the **KEY** jack on the rear panel (*with a 3-contact plug only - see the drawings below*). There are no critical adjustments for the transmitter: you just use the **RF PWR** control to set your output power. You may also wish to set the sidetone volume, as described in the box at the left.

Straight Key Operation

- With the CW mode selected, press the **VOX** button to turn on the VOX circuit, which in CW mode provides automatic transmitter activation when you close the key. For now, make sure the **KEYER & BK-IN** switches are off (■). This is the correct set-up for *semi-break-in* CW operation.
- To transmit, simply press the straight key and adjust the **RF PWR** for the desired output level. Note that if you select less than maximum power output and press the **METER** button, the meter reading will deflect beyond the ALC zone. This is perfectly normal, and does not degrade your signal.
- Courtesy of the VOX circuitry, you are now using *semi-break-in* CW, in which the transmitter remains keyed except during pauses in your sending. You can set the "hang time" during which the transmitter remains on after you stop sending, by adjusting the **DELAY** control on the rear panel. This is the same control used in VOX operation, and will affect VOX switching too, so you may need to choose a compromise setting.
- For *full break-in* (QSK) operation, simply press in the **BK-IN** button. T/R turnaround time is now improved and the receiver is active between each dot and dash. This is useful to listen for QRM or other calling stations while engaged in a QSO or calling CQ.

Using the Internal Electronic Keyer

The FT-900 incorporates a built-in, full-featured internal iambic keyer. You will need to connect keyer paddles to the **KEY** jack to use the keyer (see previous page).

- Once you have set up CW transmission as just described, you can activate the keyer by pressing the **KEYER** button, so the LED above comes on.
- Now squeeze the paddles, and adjust the **SPEED** control just to the left for the desired speed.

With the **KEYER** switch depressed, dot:dash weighting is 1:3. If you prefer 1:4.5 weighting, hold **FAST**, then press **IPO**. The display now shows the weighting selection (on/off). Rotate the tuning knob so that "□□" is displayed, then press **IPO** again. The keyer works for both semi- and full break-in keying, as described in the previous section.

For both straight-key or keyer CW operation, either the **VOX** or **BK-IN** key *must be depressed* for the transmitter to be activated via the rear-panel **KEY** jack. You can leave them off however, to use the built-in keyer and sidetone for code practice only.

Note: Sidetone *volume* is adjusted using the trim-pot at the rear of the left-side panel. To adjust the *pitch*, see below (*CW BFO Offset*).

Using an External Keyer

If you are using an external electronic keyer, you need to wire the 3-contact plug for the rear-panel **KEY** jack as shown in the example for *straight-key* operation (the external keyer now provides the dot-dash keying and weighting functions). Semi- and full-break in operation and settings still apply.

CW BFO Offset ("Pitch")

The receiver BFO offset can be varied from 400~1000 Hz (700 Hz default). CW signals tuned for a pitch corresponding to this offset will be *centered* in the receiver IF passband. This setting is also reflected in the displayed frequency offset for CW mode (you will notice this when switching to CW from another mode). If you are using a multi-mode TNC or CW decoder, you will want to set the BFO offset to match that recommended for your model (some units use an 800-Hz pitch for optimum CW decoding, check in the documentation provided with your unit). Note that the *sidetone pitch* (the beep heard when using a straight key or paddle) *also tracks the BFO offset pitch*.

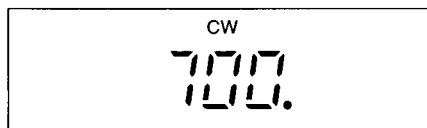

- To change the CW offset *and* sidetone pitch, hold the **FAST** button while pressing **ATT** to display the current offset (pitch) setting.
- Next, use the main tuning knob or **▼DOWN/UP▲** buttons to select the desired offset, then press **ATT** once again to save the entry and return the display to normal.

Operating Hint -"CW Spotting" You can use the sidetone monitor as a "spot tone" to center CW signals in the receiver pass-band:

- First turn off the **VOX** and **BK-IN** switches (undepressed position — **■**) so that the transmitter will not be activated for now.
- Press the key or paddles so that sidetone audio can be heard imposed over the station you are trying to tune (you may want to take the **KEYER** off-line to hear a constant tone instead of repeating dits /dahs).
- Next, slowly tune the VFO until the station's pitch matches that of the sidetone. His signal is now centered in your passband, and your TNC or decoder should now give you the best copy.

Turn on the **KEYER** and **VOX** or **BK IN** switches again and give the station a call, if you want. With the signal centered you can now insert a narrow bandwidth filter (optional) without having to retune.

Reverse CW Sideband

When you switch modes between CW and USB, you may notice that the frequency of the received signal stays the same (even though the panel frequency display may change slightly). Also notice that in both CW and USB, the pitch of a received signal *decreases* as you *increase* the dial frequency.

However, switching to LSB from CW normally requires retuning the desired signal. This can be especially inconvenient if you enjoy working the lower HF bands (40 meters and below) where LSB mode is used.

To eliminate the need for retuning in this situation, the receiver CW carrier oscillator injection can be switched to the high side (same as used for LSB mode):

- Hold the **FAST** button while pressing **CW**. The display appears as below, indicating the sideband carrier injection side ("U" for upper, "L" for lower).

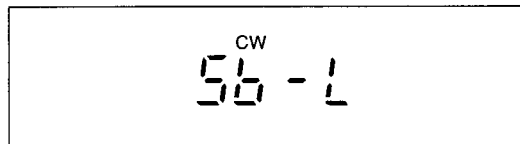

- Next rotate the main tuning knob to select the reverse sideband (L). When using the "reverse" sideband for CW reception, you can freely switch between LSB and CW after tuning a desired station without having to re-tune. Note that in LSB and CW modes the received signal pitch now *increases* with

dial frequency (a good way to confirm you are using the reverse sideband).

- To return the receiver to the default (upper) sideband for CW reception, repeat the key sequence (hold the **FAST** button while pressing **CW**).

Operating Hint - An additional benefit from this feature is QRM rejection. If you have interference on a CW station that the IF Shift control is ineffective on, try switching to the "reverse" sideband, retuning the signal, and then try the IF Shift again.

AM Transmission

Transmitter output power in the AM mode is automatically limited to 25 watts (carrier), and attempting to adjust it for a higher level will have no effect. After setting the power level, you may need to adjust the **MIC GAIN** control to avoid overmodulating. This setting will be lower than the optimum SSB setting.

- The speech processor can be used in the AM mode, but for now, make sure the **PROC** button is off, so as not to confuse adjustments.
- With the **AM** mode selected, press the PTT and rotate the **RF PWR** control for the desired power level (remember transmitter power output is limited to 25 watts in the AM mode).

- While speaking into the microphone adjust the **MIC GAIN** control just to the point where the PO meter indication begins to jump by 2 or 3 segments. Do not set the **MIC GAIN** control further clockwise, or your signal will be distorted.

- Reduce the **RF PWR** control, as necessary, for the desired output level.

See *IF Processor Frequency Shift* in the box on p.21 to setting the speech processor for AM.

FM Transmission

For FM transmission, the only control to be concerned with is **RF PWR**. Microphone gain for FM is preset internally and normally needs no adjustment after leaving the factory. Adjust the **RF PWR** control for the desired output while transmitting. To avoid overheating, if you need full power, keep your transmissions to *three minutes or less*, with the same time for reception.

Repeater Operation

The FT-900 includes several features specifically intended for repeater operation on 29-MHz FM.

To locate these repeaters, you can ask around the calling channel (29.6 MHz), or you may want to load a block of memory channels (page 27) with 20-kHz

Tuning Knob Torque Adjustment

If the tuning knob is too tight or too loose for your preference, and if you have a 2-mm hexagonal driver, you can adjust the torque.

- Pull the knurled rubber ring off of the tuning knob.
- Locate the hole in the edge of the tuning knob, and use the 2-mm hexagonal driver to loosen the setscrew accessible through the hole, just enough to allow the knob to be pulled off the shaft.
- Turn the exposed shaft tension spring counter-clockwise to loosen the torque, or clockwise to tighten.
- Replace the knob, tighten the setscrew, and replace the rubber ring.

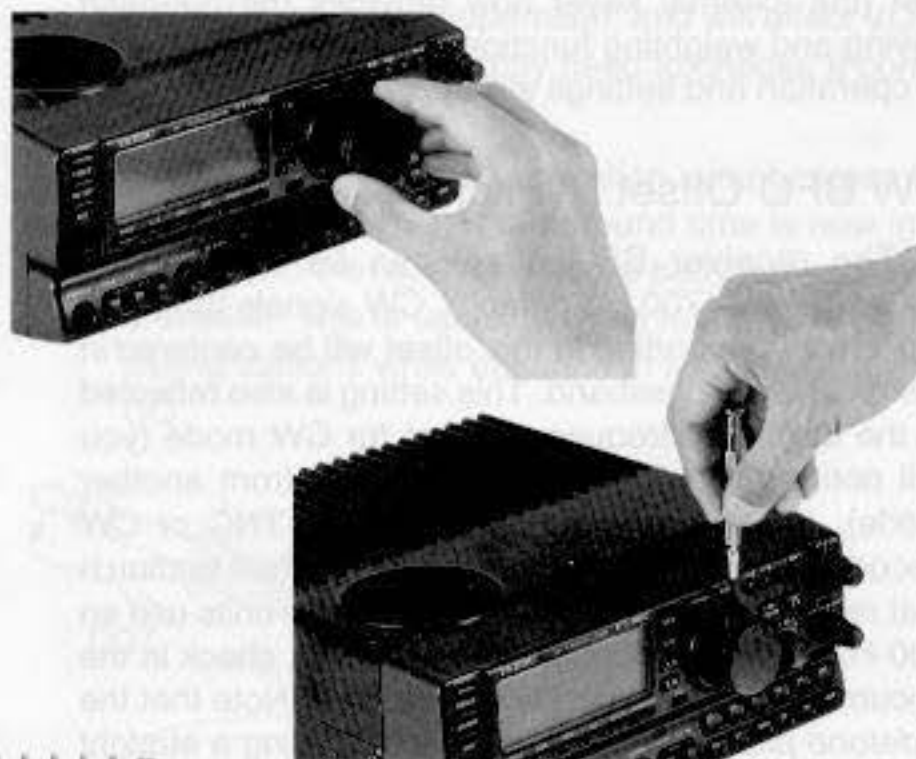

frequency multiples from 29.62 to 29.68 MHz (and FM mode, of course). Then set the squelch so that the receiver is silent on a clear channel, and press the microphone **UP/DWN** buttons to scan the memories.

When you find a repeater, press the **FM** button once for “- RPT” shift (to transmit below your receiving frequency). Pressing it again will select “+ RPT” shift, but this is not commonly used above 29.6 MHz. Press it once more to return to simplex.

Try a quick ID transmission to ensure you have the shift right (by default, the FT-900 automatically transmits a low-level 88.5-Hz subaudible tone during FM repeater transmissions, to access repeaters that require it).

After making contact through the repeater, you can store the frequency, mode, repeater shift and CTCSS encoder settings in memory for later recall.

If the repeaters you usually access have an offset other than the standard 100 kHz, you can adjust the FT-900 offset by turning it off and then back on while holding the **FM** button. This displays the offset, which can be set between 0 and 500 kHz using the tuning knob. Press **FM** once more when done.

Also, if your usual repeaters require a CTCSS tone other than 88.5 Hz* (default), you can display and select another tone by holding the **FAST** button while pressing **FM**, turning the tuning knob, and pressing **FM** again (to accept). The tone you select applies only to the current VFO, but can be stored in memory. The available tone frequencies are listed below.

CTCSS Tone Encoder Frequencies				
67.0	103.5	131.8	167.9	218.1
71.9	107.2	136.5	173.8	225.7
77.0	110.9	141.3	179.9	233.6
82.5	114.8	146.2	186.2	241.8
88.5*	118.8	151.4	192.8	250.3
94.8	123.0	156.7	203.5	
100.0	127.3	162.2	210.7	

Clarifier (Receiver Offset Tuning)

The **CLAR** button/LED and rotary control below the **▼DOWN/UP▲** buttons allow you to offset the receiving frequency from that originally displayed (and used for transmission) by up to ±9.99 kHz in 2.5-, 5.0-(default), or 10-Hz steps.

Perform the following steps, if you like, to familiarize yourself with the clarifier controls:

- Press the **CLAR** button and notice the frequency display. If any clarifier offset has been tuned before, the frequency display shifts accordingly. Turn the **CLAR** knob and notice that the frequency display changes. Now press the **CLAR** button again several times: the operating frequency returns to its original setting when the clarifier is off, and adds

Optional Clarifier Display

Normally, pressing the **CLAR** button/LED and rotating the control causes the displayed frequency to change and reflect the “clarified” frequency.

If you would prefer the display to remain on the carrier frequency, regardless of the clarifier offset, press and hold the **CLAR** button while turning on the transceiver. Clarifier operation remains as before, but the frequency display remains unchanged as you adjust the offset with the rotary control.

the offset (to the receive frequency only) when the clarifier is on.

- With the clarifier on, press the PTT switch and notice that the transmit frequency remains the same as the original (that is, non-offset) frequency display.

See the table and information in the box on page 16 (*Selecting Tuning Step Size*) to adjust clarifier tuning step size.

After you finish your conversation, remember to press the **CLAR** button/LED again to turn off the clarifier. You also might want to clear the offset (by “zeroing” the **CLAR** knob) before turning it off.

Remember! The FT-900 actually has an independent clarifier for each VFO, on every band, plus two on each of the 100 memories. This means that each clarifier offset setting is unique, and is stored so that when you change VFOs, bands or memory channels, it is active when you return to that VFO, band or memory again.

-  **Operating Hint** - Use the clarifier when you are in contact with a station whose transmitter drifts (or perhaps you were not both precisely tuned to the same frequency when you started). You don't want to change your transmitting frequency, as that would force them to retune — you just want to adjust your receiver. To do this, you can press the **CLAR** button/LED to activate the clarifier, and carefully retune their signal with the **CLAR** knob.

VFO B & Split Frequency Operation

As already mentioned, VFO B works exactly like VFO A, although each is totally independent of the other. You can use VFO B as a general-purpose “instant recall” memory. VFO B has two important purposes:

- To double memory storage capacity (described in the next section),
- It facilitates split-frequency operation (receiving on one VFO, and transmitting on the other).

The special case of split-frequency FM repeater operation uses some features of its own, as previously described. Also, if the difference in transmit and re-

ceive frequencies is less than 10 kHz, using the clarifier function is likely to be the easiest approach.

Use the **A/B** and **SPLIT** buttons to set up the two VFOs. A short explanation of each button function is as follows:

- The **A/B** button toggles operation between the two VFOs, without affecting the contents of either. When receiving on a memory, it toggles front and rear halves.
- Pressing and holding the **A/B** button (>1/2 sec.) "equalizes" VFO A & B, or the front and rear memory halves (covered later) if receiving on a memory (i.e. the contents of the currently selected VFO are written into the other VFO).
- **SPLIT** toggles the "hidden" VFO (or memory) for transmission.

For split operation, first load the VFOs with the desired transmit and receive frequencies and modes. Set your mode and frequency for transmission, then press **A/B** and set your mode and frequency for reception. You can use the **A/B** button to check your transmit frequency while receiving (to avoid transmitting unnecessarily).

Once the two VFOs are set up, just press the **SPLIT** button. "**SPLIT**" appears at the upper left edge of the display, and when you transmit, the display frequency shifts to the other VFO (and mode indicator, if different). The contents of both VFOs can be stored in a memory for future operation with the same frequency pair, as described next.

Memory Features

The 100 memories consist of ninety regular memories, labeled 01 through 90, and ten special programmed limit memories, labeled P1 through P0 (see the box at the top of the next column). Each store a pair of frequencies and modes, plus wide/narrow IF selections (for CW and AM modes), clarifier on/off and offset settings, plus split frequency status. When you recall a memory, one set of these operating parameters is displayed, and the other set is hidden. For brevity, we will refer to the displayed set of parameters as the *front half* of the memory, and the hidden set as the *rear half*.

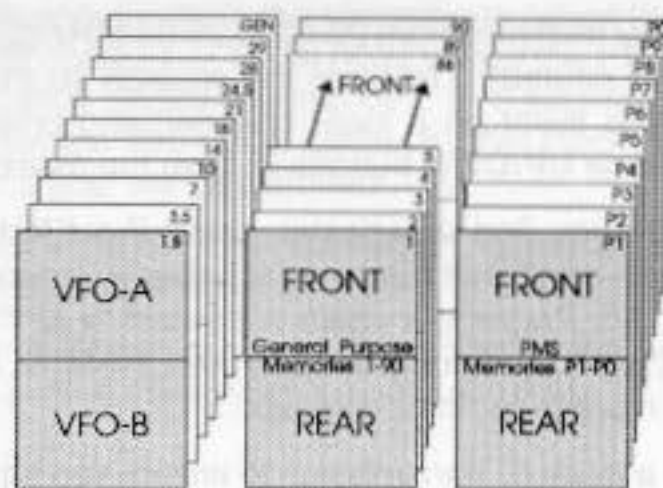

VFO & Memory Structure

The front and rear memory halves are toggled by pressing **A/B**, just as you can toggle the A/B VFOs when operating on a VFO (although the display gives no indication of which half is which, as it does with the VFOs). Like VFO operation, you can operate split with the two halves, receiving on the front and transmitting on the rear; and you can freely tune and change the mode or clarifier settings of whichever half is displayed while receiving. You can also copy a pair of settings from one memory to another. In fact, you can do nearly anything with the two halves of a memory that you can with the A/B VFOs, except for a few differences in tuning steps, scanning (only the front halves can be scanned) and the special PMS memories (P1-P0), described later.

The **V/M**, **V►M** and **M►V** buttons are used to control various memory operations, as follows:

- **V/M** toggles between memory or VFO operation. Either VFO-A or VFO-B, or MEM is displayed to the left of the frequency to indicate the current selection (see the box at the upper right on the next page). If a displayed memory has been retuned, pressing **V/M** once returns the display to the original memory contents, and pressing it again returns to the last-used VFO.
- **V►M** When receiving on a VFO or retuned memory, holding this for 1/2 second writes the current operating data to the currently selected memory. Two beeps sound, and any previous data in memory is overwritten.
- **M►V** copies the pair of frequencies stored in a memory into the VFOs (by pressing it for 1/2 second). This is described in the next section on memory storage and recall.

Panel & Microphone DOWN/UP Button Functions		
MODE	Front Panel ▼DOWN/UP▲ buttons	Microphone UP/DWN buttons
VFO-A or VFO-B	HAM Mode: Band Stepping GEN Mode: 100 kHz/1 MHz steps	Duplicates main tuning knob for VFO tuning & scanning
MEM	Memory channel stepping	Memory channel stepping and memory scanning
M-TUNE	HAM Mode: Band Stepping GEN Mode: 100 kHz/1 MHz steps	Duplicates main tuning knob for Memory Tuning
PMS	same as VFO-A or VFO-B	same as VFO-A or VFO-B

Memory Storage

You can store the contents of one or both VFOs to the selected memory channel (front and rear halves) indicated by small numbers at the right of the display. For example, to store only the displayed VFO, just press and hold the **V►M** button for 1/2 second (2 beeps sound). Operation stays on the displayed VFO, however, the front half of the memory now contains your entry (press **V/M** to display the memory and confirm your entry). Note that the other VFO is *not copied* in this particular example, and the rear memory half holds any previous entry (or the default 7.000.00 MHz if not programmed before) as shown below.

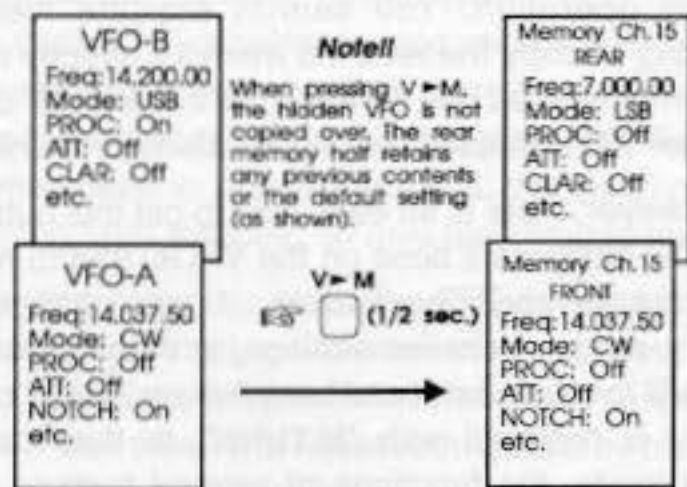

Copying VFO A to Memory 15 (Front Half)

Let's try an example of storing only the currently displayed frequency into the front half of a memory.

Ex: store 14.037.50 MHz from VFO-A into memory 15.

- First press **V/M**, if needed, so that "VFO-A" appears at the left. Select the desired mode, then tune for 14.037.50 MHz.
- Next press the **V►M** button *momentarily* so that "M CK" blinks above the memory channel display, and within 3 seconds, press the **▼DOWN** or **UP▲** button until "15" (the memory number to store) appears at the right. If nothing was stored there before, the frequency display will be blank.
- Now hold the **V►M** button for 1/2-second (two beeps sound). To confirm the memory was stored, press **V/M** to display the memory.

With the newly-entered memory displayed, you can now copy VFO-B to the rear memory half if desired:

- Press **A/B** to display the rear memory half, then return to VFO-A by pressing **V/M**.

Memory Channel Display

By default, the current memory channel selection is displayed next to the operating frequency on the LCD during both VFO and memory operation.

If you prefer to have the channel number and "CH" display turned off during VFO operation, just hold the **V►M** button while turning the transceiver on. Repeat this procedure to cancel the change.

Frequency Display Modes

VFO display with 10-Hz digit activated (page 15).



Press **V/M** to switch to MEM mode. MEM mode display of memory 15 with same frequency:



Turn the tuning knob or press the mic. **UP/DWN** buttons to switch to M-TUNE mode:



M-TUNE mode display of retuned memory 15. Press **V/M** once to cancel changes and revert to MEM mode, and press **V/M** again to return to VFO mode.

- Next, press **A/B** to display VFO-B. With the rear memory half and VFO-B now aligned correctly, press **V►M** for 1/2 sec. as before. This copies VFO-B into the rear half of the memory.

Aligning and copying each VFO to memory one-at-a-time is a straightforward approach, however, there is an *easier and faster method* that copies VFO-A and VFO-B into both memory halves *simultaneously*.

- After setting up both VFOs as desired, simply press the **SPLIT** button ("SPLIT" displayed) before holding **V►M**. This copies both VFOs into both halves of a selected memory (along with split operation) as shown below. You can later turn off the split setting in the selected memory (halves) by pressing **SPLIT**.

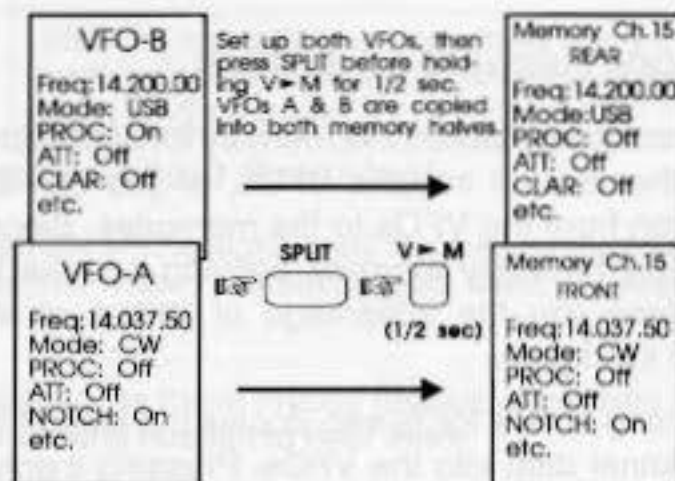

Using SPLIT to copy both VFOs to both Memory halves

Checking Memory Contents

Before storing or recalling a memory, you will usually want to check its contents. If you are operating on a VFO, you can of course just press **V/M** to recall the last-used memory, but this has disadvantages: any current operation is interrupted as your frequency changes, the antenna tuner re-tunes (if installed), and you'll have to press **V/M** again to get back to the VFO. Also, this will not work if you are operating on a retuned memory: you will lose any changed settings entirely! So, the FT-900 offers a way to display the (front) contents of memories without affecting current VFO (or retuned memory) operation, and requiring only one key press. We call it *memory checking*, and you already did it in the preceding example.

Momentarily pressing either **V ► M** or **M ► V** activates memory checking. As you saw above, "**M CK**" blinks near the top right of the display as the frequency and mode indicators change to show the contents of the last-selected memory. If you touch nothing else, the display reverts to your current operating parameters automatically after 3 seconds. By pressing the front panel **▼DOWN** or **UP▲** buttons before the 3 seconds expires, you can select for display the front half of each of the 100 memories. Pressing these buttons restarts the 3-second timer, so as long as you are changing channels, memory checking mode persists.

While checking memories, the memory number shows at the right end of the display. Also, when you select a vacant memory, the mode indicators and frequency display go blank (except the decimals).

 **Note:** When checking memories, both vacant and filled memories are displayed. If you would like to skip over vacant memories, press the **FAST** button before memory checking.

Still, memory checking does not show you everything you've stored; it only shows the visible front half of the memory. To display the frequency, mode and clarifier settings stored from the other VFO you have to recall the memory and press the **A/B** button. So, when storing memories with the intention of using both halves (front and rear), it is a good idea to have them related in some way so that you can recognize both later when only the contents of the front half appear.

Memory Recall & Operation

To recall data stored in a memory for operation, you can either copy it into the VFOs, or you can switch operation from the VFOs to the memories. Since you can freely tune any memory, copying it to the VFOs only gives you the advantage of **VFO-A** or **VFO-B** display indication.

Holding **M ► V** for $\frac{1}{2}$ sec. copies the current memory channel data into the VFOs. Pressing it only momentarily shows you the contents of the memory, without overwriting the VFO data. Otherwise, when you press and hold this button, you lose the previous

contents of both VFOs, and if you were receiving on a VFO, operation shifts to the frequency and mode copied from the memory (and now in the VFO).

In most situations it may be more convenient simply to switch operation from the VFO to the memory, by pressing the **V/M** button. This method allows you to leave any settings in the VFOs undisturbed, so you can instantly recall them just by pressing **V/M** again.

When actually operating on a memory (if you haven't retuned it), "**MEM**" is displayed at the left (instead of "**VFO-A**" or "**VFO-B**"), and you can press the **▼DOWN/UP▲** buttons on the panel (or the microphone buttons) to select any previously stored memory for operation. You cannot activate memory checking or copy the recalled memory directly to another memory, as the function of the **V ► M** button changes as described later under *Memory Blanking*.

However, there is an easy way to get this button to work the same as it does on the VFOs, and to regain the memory checking feature: if you change frequency, mode or clarifier settings, or if you press and hold **A/B** to switch front and back halves, "**MEM**" on the display is replaced with "**M TUNE**". In this *memory tuning* mode, the functions of several buttons differ from the ordinary memory recall mode: the **▼DOWN** or **UP▲** buttons select ham bands or 100-kHz steps (as when operating on the VFOs), the microphone buttons duplicate the tuning knob functions instead of the front panel **▼DOWN/UP▲** buttons, and the **V/M** button cancels any changes to the memory and returns you to the memory recall mode ("**MEM**" displayed again), instead of switching to the VFOs.

The memory tuning mode makes operation on memories 1 to 90 just as flexible as the VFOs (memories P1 ~ P0 have special additional features, described later). If you want to save changes to a memory channel, use the same procedure you use to store the VFOs to memory: Press **V ► M** momentarily and use the **▼DOWN/UP▲** buttons to select another memory (if desired), or just hold **V ► M** for $\frac{1}{2}$ -second until the double beep sounds (to overwrite the current memory with the retuned data). The labeling of the **V ► M** button is somewhat deceptive here: the VFO settings, which are hidden at this point, are not involved in this operation at all, since those of the recalled memory have taken their place.

As mentioned above, to cancel any changes you have made to a recalled memory, press **V/M** once ("**MEM**" is displayed again), and press it again if you want to return to the VFOs. The display changes are summarized on the previous page.

Split operation can be enabled and stored in a memory, in which case the rear half of the memory is used for transmission. Similarly, pressing the **A/B** button while receiving on a memory switches operation between the front and rear halves of the memory (don't forget both of these functions also activate memory tuning).

Scanning Features

After you have programmed several memories, you can scan them later to check for activity on those frequencies. The 100 memories in the FT-900 offer some choices regarding how they are scanned, and, after the following brief description, you can decide how to tailor scanning for your operating needs.

When receiving on a recalled memory (with "MEM" displayed), you can scan the front halves of all stored memories. Just hold the microphone **DWN** or **UP** button for 1/2 second to start. If you want scanning to pause on signals, you must first adjust the **SQL** control to silence the receiver (green **BUSY** LED off) on a clear channel. Scanning pauses on any channel having a signal strong enough to open the squelch, and the two decimal points in the frequency display blink. You may need to readjust the **SQL** control to prevent scanning from stopping on only background noise.

To stop scanning press the **PTT** switch (no transmission will occur), or a microphone button again. When scanning, keep in mind that the **IPO** and **ATT** buttons also affect the squelch threshold by changing receiver front-end sensitivity.

Scan Resume Mode

By default, with the **SQL** control adjusted to silence the receiver, scanning resumes soon after the signal disappears (carrier-drop resume). Alternatively, you can also have scanning resume automatically after 5 seconds, *whether the signal remains or not* (time-delay resume). To toggle these scan-resume modes, turn off the transceiver, then turn it on again while holding the **V/M** button. See the table below for a comparison of these two scanning modes.

Scan Resume Mode	Scan Resume Operation Comparison & Comments	
	w/SQL control "closed" (BUSY LED off)	w/SQL "open" (BUSY LED on)
<i>Carrier-Drop</i>	Scans selected memories for activity, pauses when a carrier strong enough to open the squelch is received. Decimal points blink while scanning pauses. Scanning resumes five seconds after carrier drops.	Decimal points blink and scanning does not continue - squelch must be adjusted to quiet receiver for scanning to start again.
<i>Timed (5-sec. delay)</i>	Same as above, except that scanning resumes after 5 seconds, whether the carrier remains present or not.	With the squelch open, scanning steps through each selected memory channel, "sampling" each for 5 seconds.

A Few Important Tips to Remember About Scanning!

- ☞ The **SQL** control setting is critical, if it is too "tight", only extremely strong signals will force scanning to stop. Too "loose" of a setting results in intermittent scanning, as the scanner "falses" on band noise, static or unreadable signals.
- ☞ Check the **ATT** & **IPO** buttons to make sure they are not engaged, as these reduce receiver sensitivity and ultimately affect what signals will be heard, and the relative squelch setting needed to hear them.
- ☞ Remember which memories you have masked or selected for scan-skip, and re-enable them if desired.

Memory Scan Skip

Once you have stored many memories, you probably won't want to scan every one of them. You can disable some of them from being scanned (see below). To do this, recall the memory to be skipped, and hold the **FAST** button below the left side of the tuning knob (or the **FST** button on the microphone) while pressing **V/M** momentarily. "SCAN" disappears above the memory number at the right. If you have disabled a memory to be skipped, and later want to enable it again, just repeat the **FAST** + **V/M** procedure.

Memory "Masking"

After storing many memories, you may want to completely hide some from normal operation, to simplify selection of the others. To mask a displayed memory, while "MEM" is displayed at the left of the frequency, press and hold the **V ▶ M** button for 1/2-second until the double beep sounds. But be careful: if you do this instead while "M TUNE" is displayed — that is, after retuning the memory, the retuned data will overwrite the original memory data, but it will not be masked. So, if you have retuned the memory and don't want to save the changes, cancel them first by pressing **V/M** once, and then hold **V ▶ M** for 1/2-sec.

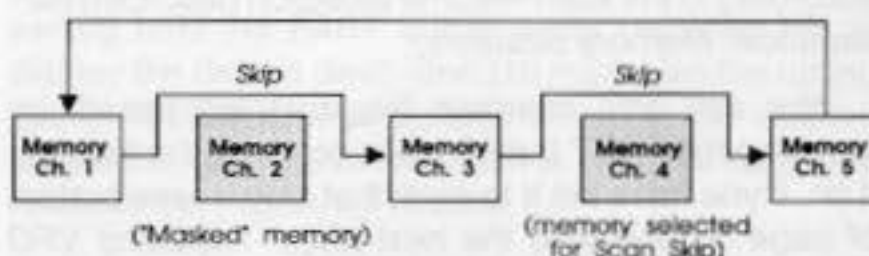

Memory Channel Scanning in the FT-900

While a memory is masked, no frequency digits appear (the two decimal points remain), and “SCAN” disappears above the memory number at the right end of the display, as shown below.

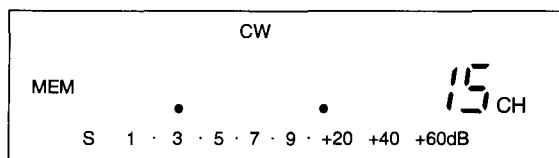

Masked Memory Selected for Display

Masked memories are also skipped during memory scanning (see drawing on the previous page). As long as you don't overwrite a masked memory, you can unmask it simply by repeating the same procedure you used to mask it.

Band & Subband Scanning: Subband Limit Memories P1 ~ P0

As you have probably already discovered, when operating on a VFO or retuned memory, holding either the **DWN** or **UP** button on the microphone for 1/2 second starts scanning, and pressing one of these buttons again stops it. By setting the **SQL** control so that the receiver is just silenced on a clear frequency, scanning will pause when it finds a signal, and resume according to the scan-resume selection described earlier under *Memory Scanning*.

You can also increase the scanning speed, by pressing the **FAST** button while scanning (or toggling it on, if you have set it to work that way — see bottom of page 15 and also the next page -*Adjusting VFO Scanning Speed*).

If you let scanning continue indefinitely, it will loop around when it reaches 0 or 30 MHz, including the entire range of receiver coverage. To limit scanning to a *particular frequency range*, you will want to make use of the programmable scanning limit (we call it *PMS*) facility provided with these ten special-purpose memories (P1 through P0).

To limit the tuning range to a particular subband, store the edges of the range in the front and rear halves of these memories. Then recall the desired memory (tuning range) and activate memory tuning. Tuning and scanning now loop around the ends of the stored range, keeping operation inside the programmed subband.

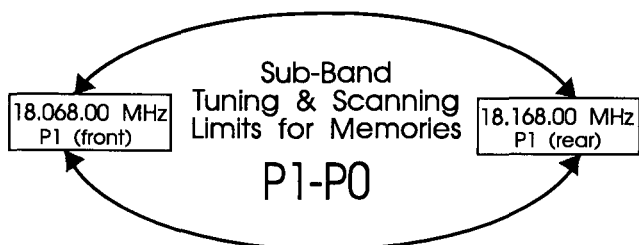

You can change modes and use the clarifier as when retuning any other memory, but don't bother to press **A/B** to switch halves of the memory, or press the **▼DOWN/UP▲** buttons: as soon as you try to tune with the knob or microphone buttons, operation instantly switches back to the subband. Also, if you activate split transmit/receive, your transmit frequency will be whatever you stored in the back half of the memory you started on (P1~P0).

Example: Limit tuning & scanning to the 17-m band.

- Press **V/M** once or twice, if necessary, to display “VFO-A” at the left. Then tune to the low edge of the 17-m band: 18.068 MHz. Also select the mode you expect to use most often (here, USB or CW).
- Press **A/B** to select “VFO-B”, and tune to the high edge of the 17-m band: 18.168 MHz. Again, select a mode you expect to use (it does not need to be the same).
- Press **V►M** momentarily to activate memory checking, and press the **▼DOWN/UP▲** buttons to select memory P1. Then hold **V►M** for 1/2 second to write the contents of both VFOs into *both* memory halves of P1 (note that enabling **SPLIT** beforehand or a two-step writing sequence is not needed here to copy both halves, as with memories 1-90).
- Press **V/M** to recall memory P1, and turn the tuning knob (to activate memory tuning).

Tuning and scanning are now limited to the 18.068- to 18.168-MHz range until you press **M/V** to return to memory channel operations, **V►M** to copy the displayed frequency to a memory, or **M►V** to write the displayed frequency to a VFO.

Copying between Memories

We previously learned the procedure for copying one or both VFOs into memories. This same technique can also be applied to copy from one memory to another. Like VFOs, one or both halves of memories can be selectively copied, however, there are a few different rules. For clarity, in the following explanation we will refer to the memory whose contents are being copied as the *source* memory and the memory being copied to as the *destination*.

- ☞ Before copying between memories, remember the following points:
 - To copy from one memory to another (including PMS memories), the source memory *must have Memory Tuning engaged*. You can do this by simply turning the tuning dial so that “M-TUNE” replaces “MEM” in the display (and then tuning back to the desired frequency).
 - During memory operation, the **V►M** button copies the contents from the source memory (or memory pair) to a destination memory.

With these few things in mind, let's try the example at the top of the following page:

Ex. Copy both halves of memory 15 (used in the example on page 27) to PMS memory P5.

- ❑ Press **V/M**, if necessary, for memory recall operation ("MEM" displayed at the left), then press **▼DOWN** or **UP▲**, and select memory 15 (note that the *source* memory must contain data).
- ❑ Also recall that *we must activate memory tuning* before copying one memory to another. Rotate the tuning dial to activate the memory tune function ("MEM" is replaced by "M TUNE" in the display).
- ❑ Since we want to copy both the front and rear halves to the destination memory, press **SPLIT** now. Next press **V►M** momentarily to activate memory checking, and use the **▼DOWN/UP▲** button to select memory P5.
- ❑ Hold **V►M** for 1/2 second to write memory 15 to memory P5. That takes care of both memory halves, and also shifts operation to memory P5 with memory tuning activated.

Now when you tune or scan, operation remains within the limits of P5 (14.037.5- to 14.200.0-MHz range).

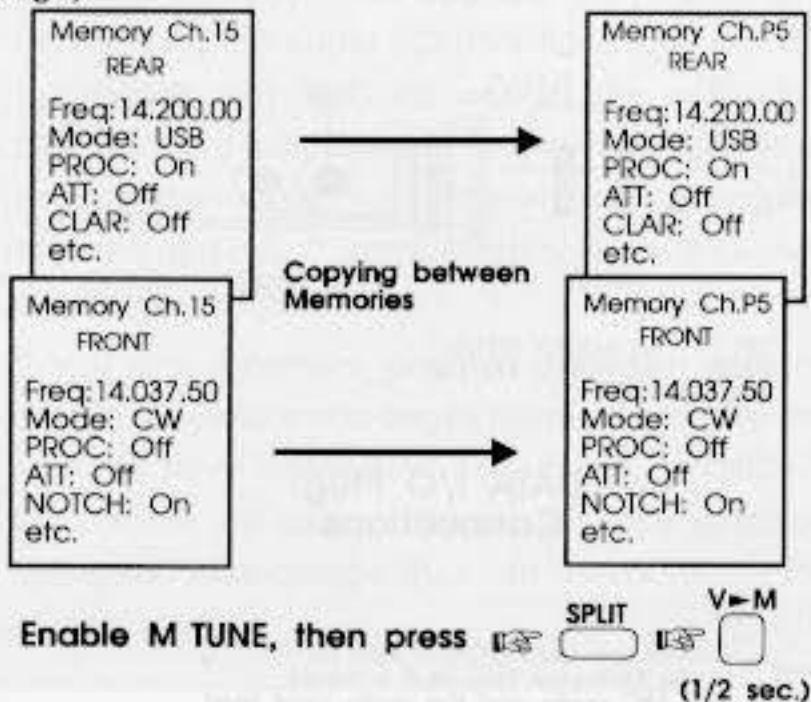

Optimizing PMS Memories

One way to optimize use of PMS memories P1-P0 is to program the upper and lower limits of all 10 amateur bands into each memory pair (front and rear). With this done, you can select, tune and scan each PMS memory as you would a VFO for each band. However, you now have the advantage of always having the subband limits enabled and never having to use the VFOs (except for storing the band limits).

Adjusting VFO Scanning Speed

Although memory channel scanning speed remains fixed, you can adjust the rate at which frequencies are scanned in the VFO mode and also when scanning a tuned memory ("M TUNE" displayed).

Note that this is different from selecting the tuning step *size* (as described on page 16), and is done by adjusting the scanning "dwell time" for each frequency step, that is, *how long* the receiver remains on a frequency before automatically tuning up or down to the next channel step.

The dwell-time setting is adjustable from 1-200 milliseconds, with 1 ms. resulting in the fastest scan rate, and 200 ms. being the slowest. To adjust this setting hold the **FAST** button while pressing **NB** to display the default dwell-time (10 ms.). Use the tuning dial or **▼DOWN/UP▲** buttons to select the desired time value, then press **NB** again to save the entry and return to the frequency display.

You can observe the speed change by simply initiating VFO scanning using the microphone **UP/DWN** buttons. Try experimenting with different values until you obtain the preferred scanning rate.

Digital Modes

The FT-900 offers a few special features for digital modes, such as the **DATA IN/OUT** jack on the rear panel, and a very fast transmit-to-receive turnaround time. This provides good performance on 1200-baud packet above 29 MHz. Unfortunately, optimum AMTOR, RTTY and 300-baud packet operation is difficult, because the optional 500-Hz narrow CW filter is not available for reception in the SSB modes needed for AFSK transmission. You can keep operation simple (and avoid the need for the 500-Hz CW filter option) by using the LSB mode with its 2.4-kHz bandwidth for both transmission and reception, but the broad receiver IF bandwidth is not optimum for receiving narrow-shift AFSK. Alternatively, if you have the 500-Hz CW filter installed, you can try using it for reception in CW mode and transmitting in SSB; but this requires offsetting your transmit and receive frequencies.

Caution!

Although the FT-900 cooling system is designed to handle continuous duty transmission at 100 watts output, full key-down output for long periods is not recommended. When operating RTTY and FM, and especially during hot or humid weather, we recommend reducing power to preserve the life of the components. In any case, during long transmissions, place your hand on the top occasionally to ensure that it's not getting too hot. The safest approach is to keep power output at 50 watts or less during long transmissions.

TU/TNC Interconnections

Connect your TU or TNC to the rear-panel **DATA IN/OUT** and **PTT** jacks, as shown below. The schematic on the next page shows the relationships of the transmitter audio inputs at the **MIC**, **PATCH** and **DATA IN/OUT** jacks. Input impedance at the tip contact of the **DATA IN/OUT** jack is about 3 kΩ, and peak input voltage should be 20 to 40 mV, so you may need to adjust the **MIC GAIN** control. Although it is possible to inject TNC audio at the microphone jack, we recommend using the **DATA IN/OUT** jack and disconnecting the microphone during packet operation to avoid transmitting shack noise on top of your signal.

Peak output voltage at the ring contact of the **DATA IN/OUT** jack is about 30 mV at 600 Ω, so you may also need to adjust the input level inside your TU or TNC.

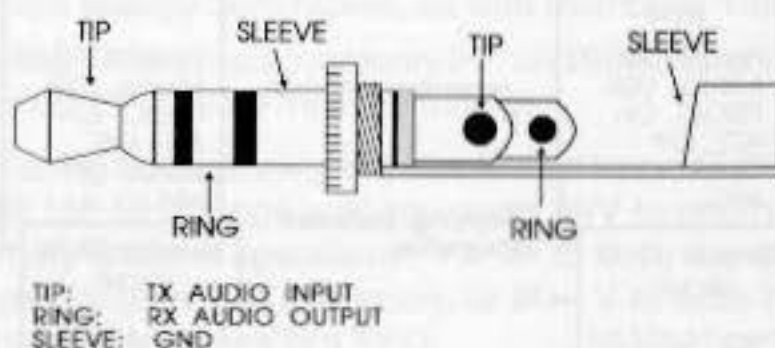

DATA I/O Plug Connections

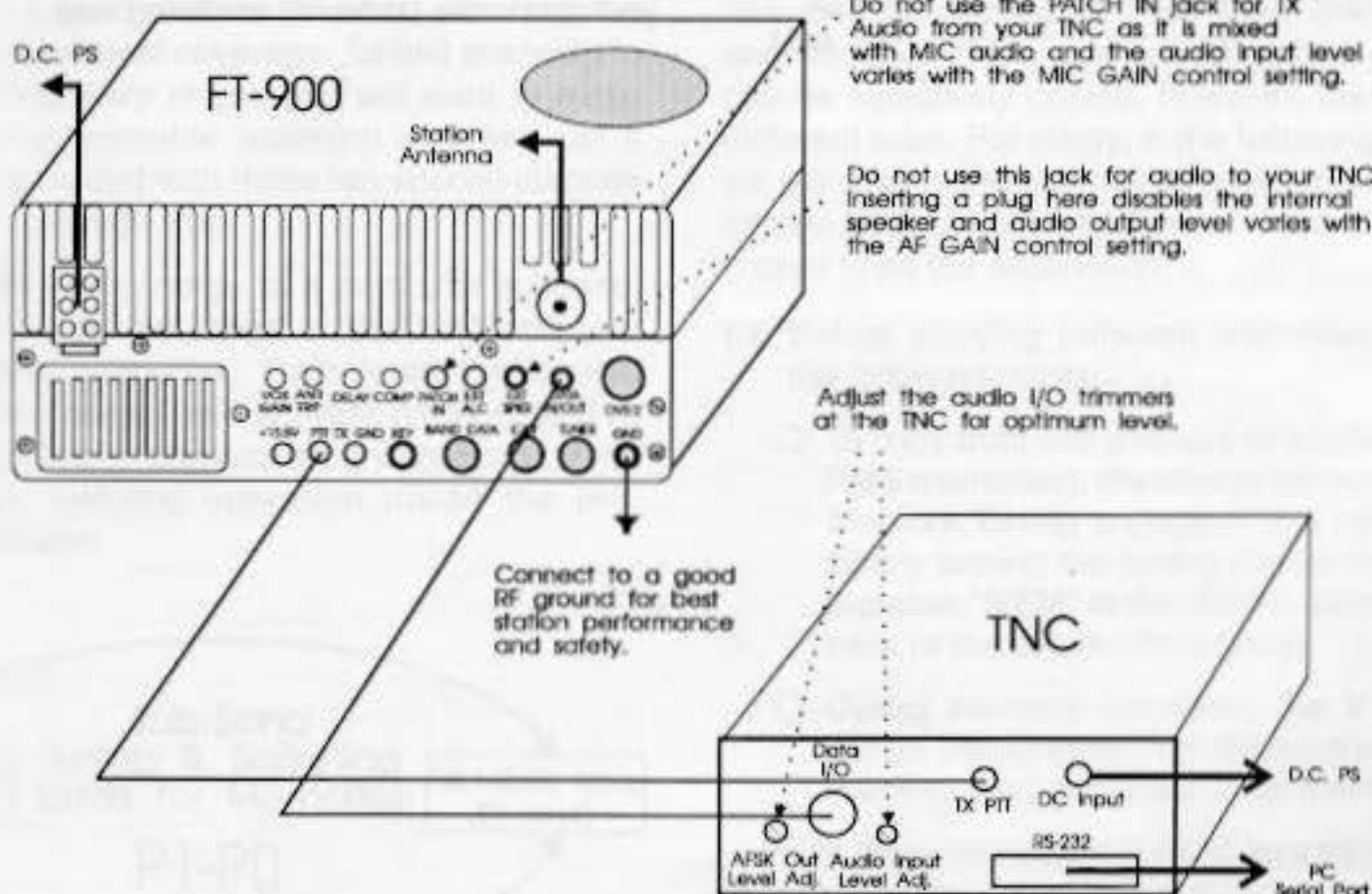

FT-900 - TNC Interconnections

Before You Begin.....

The suggestions and descriptions concerning packet TNC interconnection and operation are intended to be general, and do not encompass all aspects of the hardware, software and operating techniques used in this highly popular mode.

There is a wide range of TNC units available on the market. Audio data wiring, plugs, connectors and operation often varies between manufacturers, and in some cases between models of the same company. While in some cases "plug-in and play" operation is as simple as that, most TNC interconnections and digital operation requires familiarity with your particular TNC and patience (you will probably have to solder a few wires to make a patch cable).

Before "diving in" to digital operation, we recommend thoroughly reviewing the documentation provided with your TNC and with the FT-900. Understanding the audio I/O data flowpath between transceiver and TNC as well as the connector pin-out wiring is important. This will save you from much of the headaches and frustration associated with "hit-and-miss" cable patching and "trial-and-error" operating.

If you are uncertain, don't be afraid to ask for assistance before you begin! Although your dealer may not have connection data for every TNC on the market, he can guide you to many amateur clubs and user-groups that can be contacted for assistance.

Transmitter Adjustment

Press the **AGC** button for fast AGC, and the **SSB** mode button for LSB (normal shift). The display shows the suppressed carrier frequency, so bear in mind that your actual transmitted signal is offset below the display by the (audio) frequency of the AFSK tones generated by your TU.

Before transmitting the first time, preset the **RF PWR** control to about 12 o'clock, and unplug the microphone. Select ALC level on the meter display and then key the transmitter from your keyboard. Adjust the **MIC GAIN** control if necessary, for a level that gives less than mid-scale indication on the meter. Now you can adjust the **RF PWR** for the desired power output.

Note that for AMTOR and F1 packet operation, you must have the **VOX** button off (■) for fast transmit/receive turn-around.

Frequency Display & Tuning

As mentioned above, the transceiver displays the suppressed carrier frequency, from which you must subtract the audio frequency of your TU's or TNC's AFSK tones to find the actual operating frequency. For example, if your TNC uses 1600- and 1800-Hz tones, you can subtract the difference (1700 Hz) from the display to find the actual center frequency of your transmitted signal. Also, you want to center your receiver audio passband at 1700 Hz, so you need to turn the **SHIFT** control counterclockwise to about the 11-o'clock position (the normal SSB passband is centered about 1500 Hz away from the carrier frequency).

Of course, if your TNC or TU uses higher-frequency tones, you have to shift the passband further.

Example: You want to have a packet QSO with a station who has told you they will be on 14.1013 MHz (sometimes called the old "14.103" according to the

Transmitter AF Input Relationships

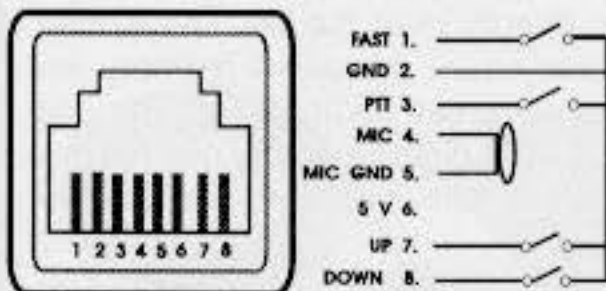

Modular Microphone Jack Pin-Out Connections

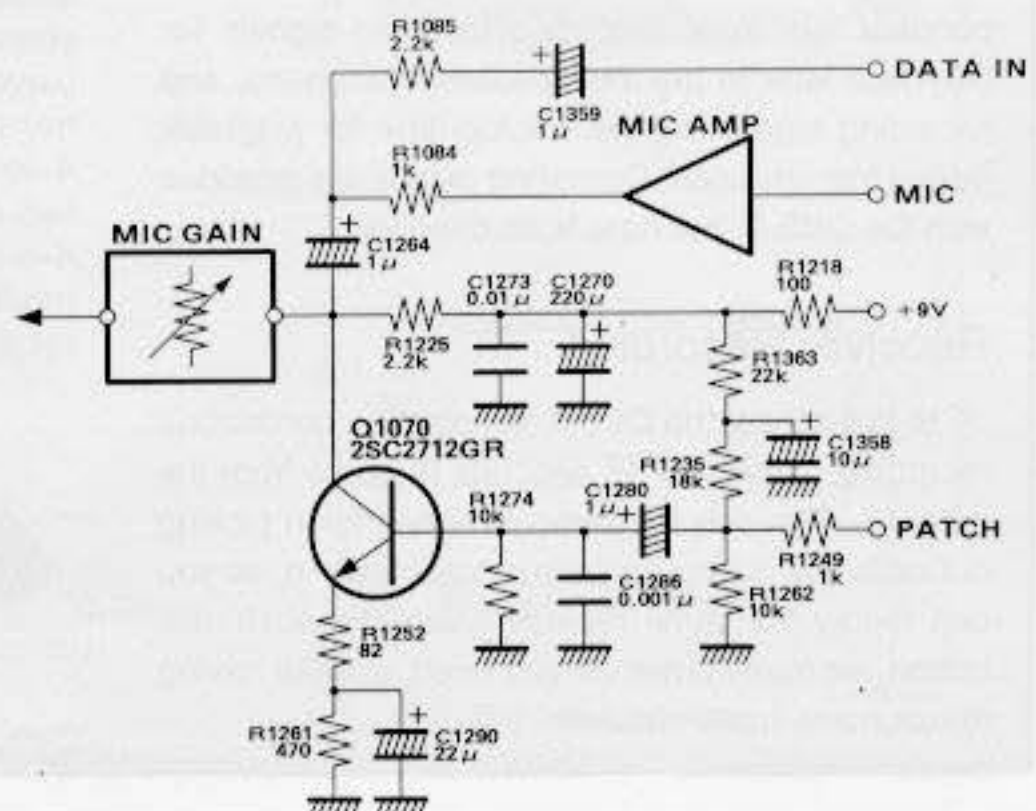

1700-Hz TAPR convention), and your TNC uses 2115-/2315-Hz tones. What frequency should your display show?

Unlike RTTY and AMTOR, which imply the mark frequency when setting up skeds, packet frequencies refer to the center of the two tones. With your modem, the carrier offset is in the middle between 2315 and 2115 Hz, or 2215 Hz. So if you're using LSB mode, you need to add this offset to the specified QSO frequency to get your displayed frequency: $14.10130 + 0.002215$ (MHz) = 14.103515, which displays as either 14.103.51 or 14.103.52. On the other hand, if you're using USB mode, you subtract the offset, and your display shows 14.099.08 or 14.099.09.

Since tuning is very critical for F1 packet, selecting 2.5- or 5-Hz tuning steps will provide the most precise tuning. Also, you should enable display of the 10-Hz digit, by holding the **▲UP** button while switching the transceiver on. Tune the transmitter and receiver within 10 Hz of a signal to minimize repeats.

1200-Baud FM Packet

The equipment setup for 1200-baud FM packet (above 29 MHz) is the same as for 300-baud packet. There is no squelch status output from the FT-900, however, so performance will be better on noisy channels if your TNC has PLL-type DCD. Tuning is much less critical in this mode, requiring no special adjustments.

To transmit FM packet, simply adjust the **RF PWR** control for the desired power level.

Note: Computer-Generated RFI

When using a TNC connected to your transceiver, or even having a PC located in the shack, the possibility exists that you may experience computer-generated RFI (Radio Frequency Interference).

The CPU in a personal computer operates with a crystal-controlled oscillator (clock) and timing circuits. Common clock frequencies include 8, 12, 16, 20 and 25 MHz. In addition, high-speed digital data switching uses square waves, which produce odd-order harmonic frequencies.

Computer-generated RFI may appear at seemingly random frequencies (usually right where a rare DX station is calling CQ!) throughout the range of your transceiver, and may sound like constant ticking or buzzing that may change as you type or work within a program. Severe RFI may have S-meter indications as much greater than S-9, making copy of voice signals difficult and data signals virtually impossible.

Computer-generated RFI is usually a result of inadequate shielding of the PC's cabinet or I/O and peripheral connections. While computer equipment may comply with RF emission approval standards, this does not ensure that sensitive amateur radio receivers will not experience RFI from the device.

There are a few steps you can take to reduce or eliminate computer-generated RFI. The first step is to ensure that only shielded cables are used for TNC-to-transceiver connections, carefully check RF ground connections and re-orient your station equipment in relation to the computer. Try moving your PC and

Optional DVS-2 Digital Voice Recorder

The DVS-2 is a digital recorder that can greatly enhance DXing, voice contesting and net operations. The FT-900 has a special jack for connecting the DVS-2 on the rear panel. It offers two independent functions: recording received signals for playback later in the loudspeaker/headphone, and recording signals by the microphone for playback during transmission. Operating details are provided with the DVS-2, but here is an overview.

Receiver Recording

In this mode, the DVS-2 maintains a continuous recording of the last 16 seconds of audio from the receiver. This can be particularly helpful in picking out callsigns during a pileup or net check in, as you can replay the same recording with the push of a button, as many times as you need, without having to ask for re-transmissions.

Transmission Recording

This mode allows the DVS-2 to record either two 8-second segments or four 4-second segments of audio from the microphone, such as contest exchanges, station IDs or net calls. Each can then be played back, either in a monitor mode (without transmission), or directly over the air. The 8- and 4-second segments share the same memory, so two 4-second segments can be combined into one 8-second segment. The digital memory used in this mode is independent from that used for receiver recording.

peripherals slightly and see if it has any affect on the RFI, in some cases, this alone may be enough to correct the problem.

If not, several additional steps to try include installing AC line filters on the power cord(s) of the suspected equipment and inserting decoupling ferrite toroidal chokes on interconnecting patch/data cables and smaller ferrite beads on single wires.

As a last resort, you can try installing additional shielding within the PC case, using appropriate conductive mesh/screening or conductive tape. Especially check RF "holes" where plastic is used for cabinet front panels. For further information, consult amateur radio reference guides and publications relating to RFI suppression techniques.

YSK-900 Features and Speaker Audio Selection

The removable front sub-panel of the FT-900 allows increased flexibility when operating from an automobile or boat. For remote mounting, you will need the YSK-900 Separation Kit and MMB-20 Mounting Bracket. The Separation Kit includes a 6-meter length of interface cable with pre-assembled connectors, quick-release mounting adaptor and hardware. The YSK-900 mounting adaptor installs on the rear of the FT-900 sub-panel and provides a base for dashboard mounting (using adhesive strips or screws). For adjustable mounting, a gooseneck or ball-joint vise stand (purchased separately) may be attached. Complete mounting instructions are provided with the YSK-900 Kit.

IMPORTANT!

Internal/Sub-Panel speaker audio is selected using a switch accessible through a hole in the bottom case cover (see below). From the factory, this switch is set to the the **ON** position, and receiver audio is normally available from the internal speaker. Moving the switch to **OFF** disables the internal speaker, and speaker audio is now available *at the jack on the rear of the sub-panel*. A speaker can be plugged in here and then mounted nearby for comfortable listening.

*Remember to move the switch when separating or re-installing the sub-panel or else your tranceover may appear to have no audio output from the internal speaker (audio is always available at the rear-panel **EXT SPKR** jack when a plug is inserted there, regardless of the speaker switch position).*

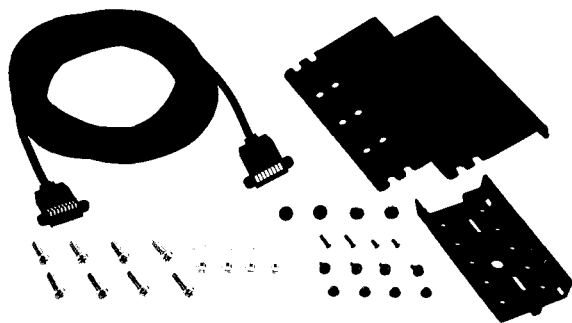

YSK-900 Separation Kit

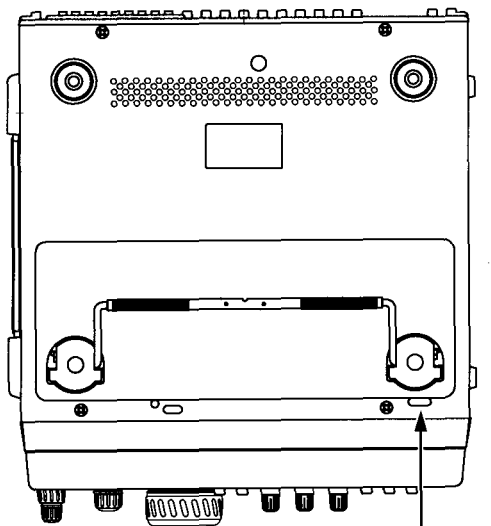

Switch Location

INT. SPKR
Switch
OFF ← ON

Installing Internal Accessories

This chapter describes installation of the internal options available for the FT-900. The ATU-2 automatic antenna tuner and the XF-110C or XF-110CN and XF-110S crystal filters are installed by removing only the bottom cover, while installing the TCXO-3 master oscillator requires removing first the bottom cover and then the top cover/heatsink. This chapter describes the cover removal procedures first, followed by the individual procedures for each option. Proper performance with these options depends on proper installation. If you are unsure of the procedures after reading the following, please ask your Yaesu dealer for help.

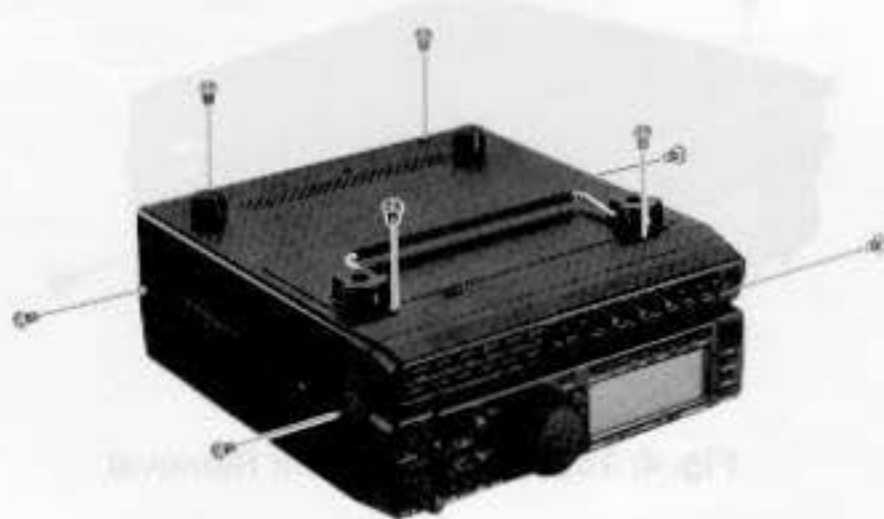

Figure 1: Bottom Cover Removal

Cover Removal

- Turn the transceiver off, and disconnect all cables.
- Place the set upside-down on the work surface with the rear facing you, and remove the eight screws affixing the bottom cover (Figure 1). Then lift the bottom cover off.

If you are installing only the ATU-2, proceed directly from here to the procedure on page 40.

- Disconnect the light-blue-banded coaxial cable from J2026 near the rear of the exposed RF Unit (① in Figure 2). If you are not installing any crystal filters, skip the next three steps.
- If installing crystal filters you will need to access the solder side of the RF Unit. Unplug the yellow-banded coaxial cable from J2024 near the rear corner of the RF Unit (② in Figure 2).
- Using a small sharp tool, gently pry up on either side of J2011, the white plastic ribbon cable socket near the rear left corner of the RF Unit (③ in Figure 2), about 2 mm ($\frac{1}{8}$ inch), until the ribbon cable can be removed (see Figure 3).
- Remove the six screws indicated in Figure 2 (one is inside the large shield housing, accessible through the hole near the corner).
- If not installing the TCXO-3, the crystal filters can now be installed as described on page 40. Otherwise, continue with the following steps:

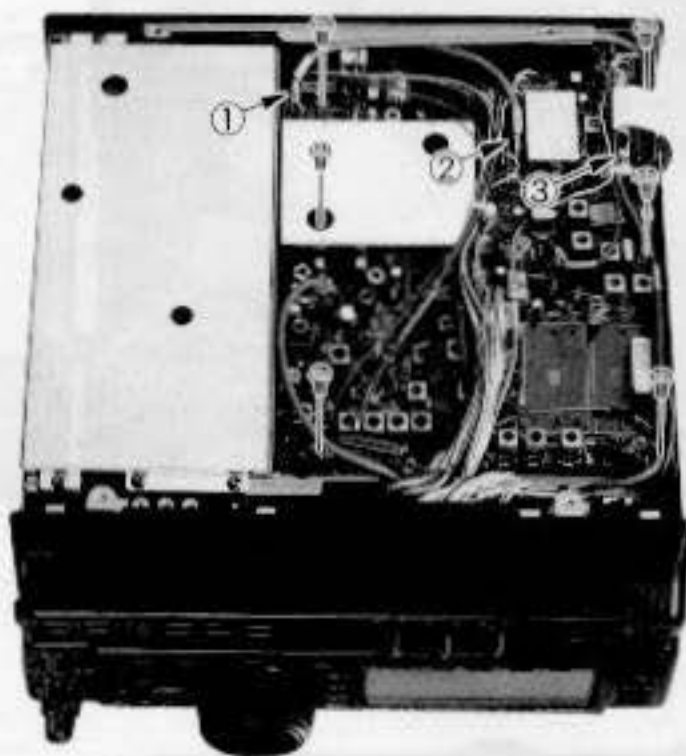

Figure 2: RF Unit Location

TCXO-3 Enhanced-Stability Crystal Oscillator Option

The ± 2 -ppm TXCO-3 option can be installed as a replacement for the standard ± 10 -ppm crystal oscillator.

- Place the transceiver topside-up, and remove the four screws indicated in Figure 4.
- Now turn the transceiver onto its right side (as viewed from the rear). Lift the rear of the top cover/heatsink about 2 cm ($\frac{3}{4}$ inch), then slide it back slightly and begin to fold away the uppermost side. Using care to unhook the coaxial cable that was disconnected above from the RF Unit, fold the two halves of the chassis apart until they lay flat, side by side.

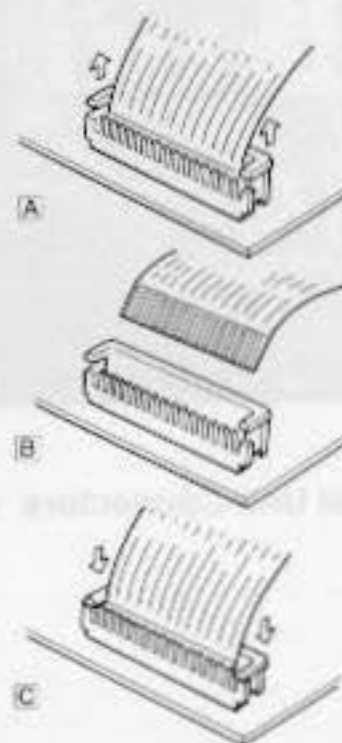

Figure 3: Ribbon Cable Connector



Fig. 4: Top Cover/Heatsink Removal

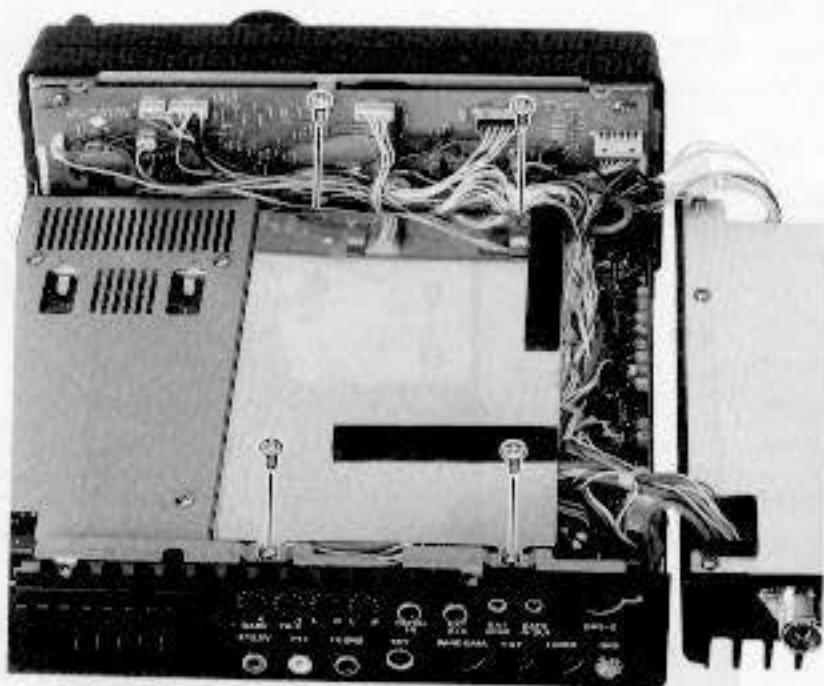

Figure 5: Local Unit Shield Cover

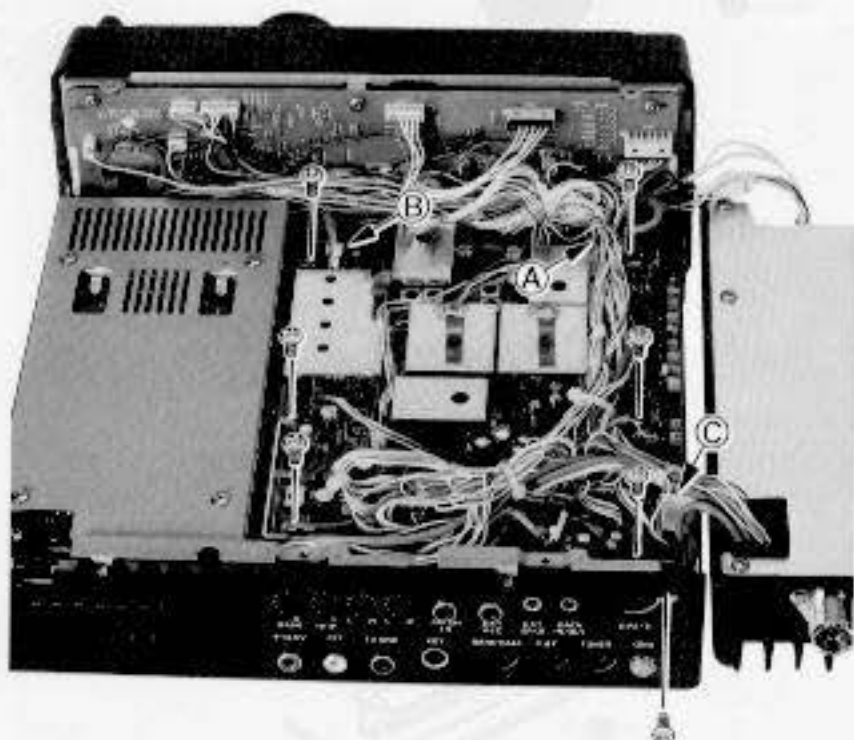

Figure 6: Local Unit Connectors and Screws

- Remove the four screws affixing the shield cover over the Local Unit (Figure 5), then remove the shield.
- To access the solder side of the Local Unit, first remove the wire harness from its tie downs (point **A** in Figure 6). Then unplug the coax connector (**B** in Figure 6) and the ribbon cable (**C** in Figure 6) by gently prying up each side of the connector as shown in Figure 3.
- Remove the seven screws shown in Figure 6 (note that one is next to the DVS-2 jack on the rear panel), and also remove the upper one of the two screws on either side of the front panel (Figure 7) and loosen the lower one (on each side), allowing the front panel to be folded forward so that the Local Unit can be lifted as shown in Figure 8 (next page).
- Referring to Figure 8, locate capacitor C1323 and resistor R1361 on the board just behind the oscillator housing. Cut the leads of these parts and remove them.
- Straighten the leads on the TCXO-3 module, if necessary. Then position it so that the trimmer hole is oriented as shown in Figure 9 (the label should be upside-down when viewed from the rear), and push the module leads through the board. Hold the module snug against the board while soldering it in place on the other side. Cut any excess lead length.
- Replace the Local Unit board in the chassis, then reinstall the wiring harness in its tie-downs, ensuring no wires are pinched. Reconnect the cables removed from the board, and replace the six screws in the board and one in the rear panel (Figure 6), and the two on each side of the front panel (Figure 7).

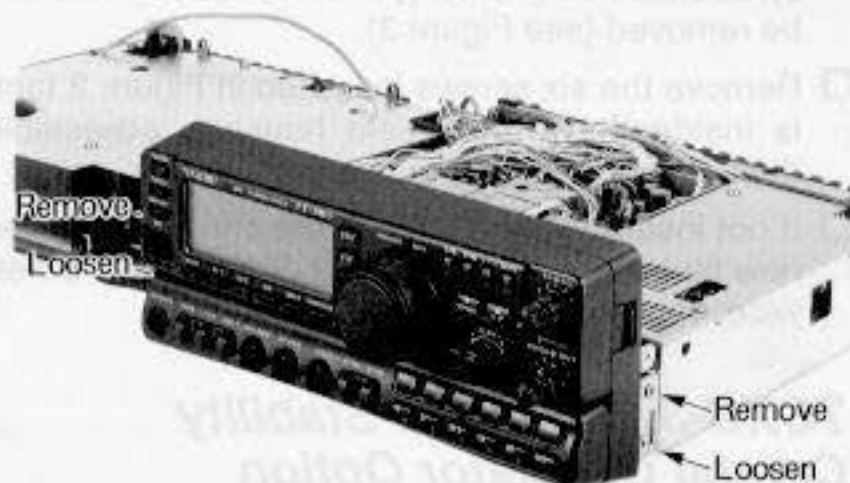

Figure 7: Front Panel Screws

Optional IF Crystal Filters

The 500-Hz XF-110C or 250-Hz XF-110CN crystal filters may be installed for CW narrow reception, and the XF-110S 2.6-kHz crystal filter may be installed for improved SSB and AM narrow receiver selectivity.

- If you haven't already, perform the first six steps under *Cover Removal* at the start of this chapter.
- Referring to Figure 10, determine the location of the filter(s) you are installing (the XF-110C and XF-110CN cannot both be installed, as they use the same mounting location). If installing either filter for CW narrow, remove the jumper plug.
- If installing the XF-110S for SSB and AM narrow, refer to Figure 11, lift the rear edge of the board and carefully unsolder and remove the ceramic filter. Straighten the new filters' leads, if necessary. Then position each filter as indicated in the photos, and push the filter leads through the board.
- Lift the rear edge of the board and solder each filter lead on the solder side of the board while holding the filter snug against the board. Then clip off any excess leads. Check your solder joints carefully. Replace the board in the chassis, using care to avoid pinching any wires.
- Replace the six screws removed from the RF Unit (Fig.2), and replace the coaxial cables (① and ② in Fig. 2): the yellow-banded cable goes in J2024, and the light-blue-banded cable goes in J2026.
- Referring to Figure 3C, replace the ribbon cable into its connector, and press down firmly on both sides of the socket while pressing the ribbon cable into the socket. Confirm that it is firmly in place.
- Unless installing the ATU-2, replace the bottom cover (bail towards the front) and its eight screws.

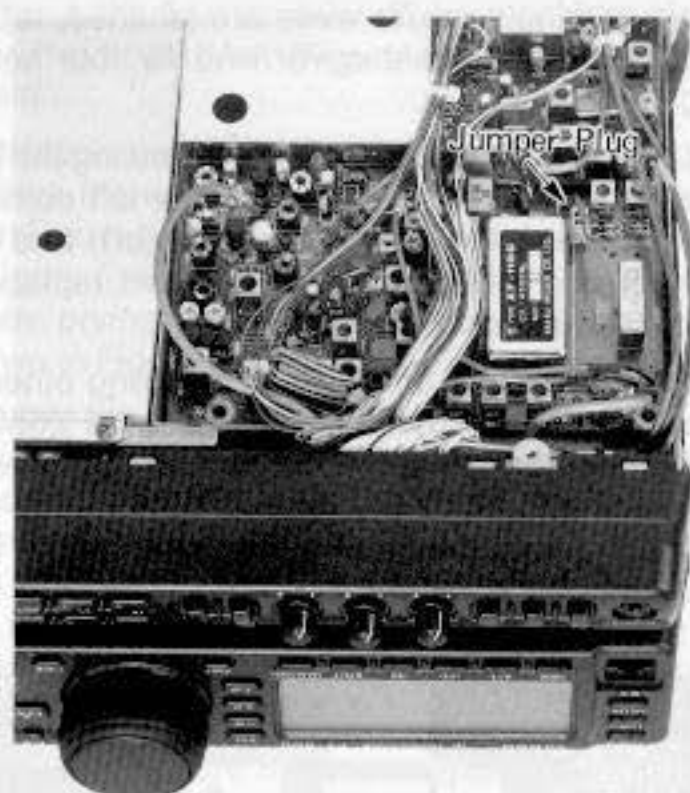

Figure 10
CW Filter, Jumper & Ceramic SSB Filter

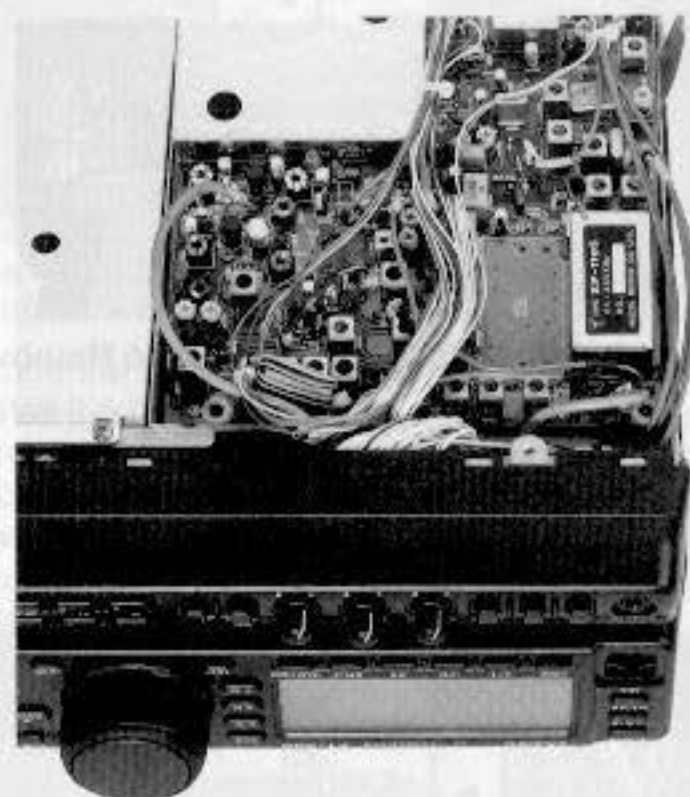

Figure 11
SSB Filter Location (replacing Ceramic Filter)

ATU-2 Internal Antenna Tuner

- If you haven't already, perform the first two steps under *Cover Removal* at the start of this chapter.
- Locate the two unconnected coaxial cables and three unused plastic connectors in the space on the right side of the chassis (as viewed from the rear).
- Position the ATU-2 so that the tab with the two mounting holes is toward the front of the transceiver, nearest the upward-facing bottom edge of the front panel.
- Connect the unused cables to the sockets on the rear of the ATU-2. The green-banded coax goes to J6502, the red-banded coax to J6510, and the 4-, 5- and 6-pin connectors to J6504, J6505 and J6506, respectively.
- Position the ATU-2 in the chassis, and mount it with the three supplied screws. If you installed the TCXO-3 but no crystal filters, replace the light-blue-banded coax into J2026 on the RF Unit.
- Replace the bottom cover (with the bail towards the front) and its eight screws.



Figure 12: ATU-2 Connectors

CAT System Computer Control

The CAT (Computer Aided Transceiver) System in the FT-900 provides control of frequency, VFO, memory and other settings using an external personal computer. This allows multiple control operations to be fully automated as single mouse click or keystroke operations on the computer keyboard.

To use computer control of your transceiver, you will need the optional FIF-232C Interface Box. This device connects between the transceiver and computer, and converts the digital signal levels for proper data transfer. Each time a command instruction is being received from the computer via the FIF-232C, the "CAT" indicator appears in the lower left corner of the display, then turns off afterward. The cable connecting the transceiver to the FIF-232C is supplied, however, you will need a serial cable for connection to the RS-232C (serial or COM port) connector on your computer. Purchase standard serial cable (not the so-called "null modem" type), ensuring it has the correct gender and number of pins (some serial COM port connectors use a 9-pin rather than 25-pin configuration). If your computer uses a custom connector, you may have to construct the cable. In this case, refer to the technical documentation supplied with your computer for correct data connection. The illustration at the bottom of this page shows an example of CAT system interconnections.

Yaesu Musen does not produce CAT System operating software due to the wide variety of personal computers and operating systems in use today. However, the information provided in this chapter explains



FIF-232C CAT System Interface Box

the serial data structure and opcodes used by the CAT system. This information, along with the short programming examples, is intended to help you start writing programs on your own. As you become more familiar with CAT operation, you can customize programs later on for your operating needs and discover the true operating potential of this system.

If you do not wish to write your own programs, there are some commercially produced software packages available, as well as various shareware and freeware programs. To find out more information, contact your dealer or check advertisements in current amateur radio journals and publications. Other valuable information sources include amateur radio and PC users-groups, packet radio and PC bulletin boards (BBS) and amateur radio swap-meets (hamfests).

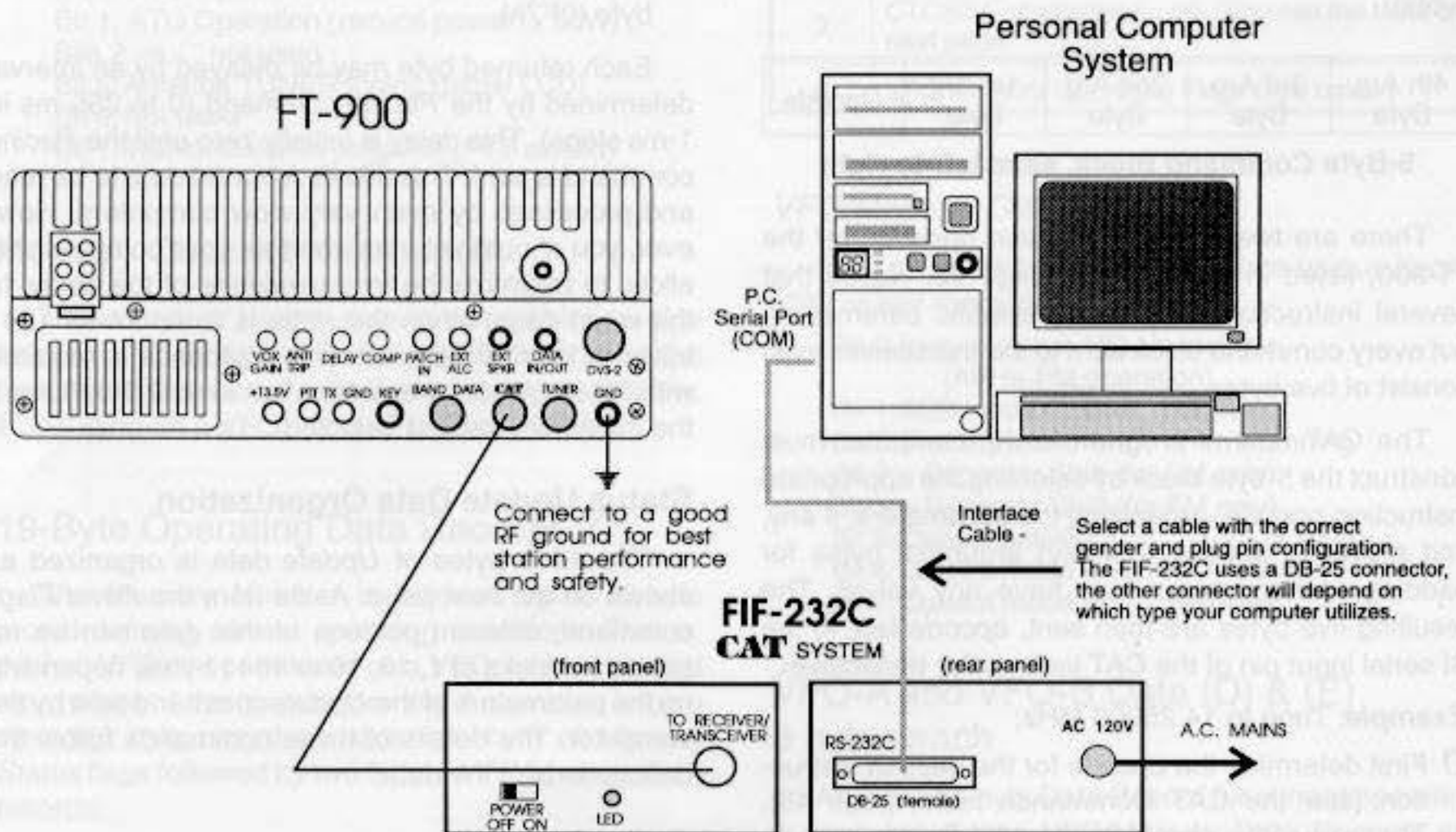

CAT System Interface with the optional Yaesu FIF-232C Unit.

CAT Data Protocol

Serial data is passed at TTL levels (0 and +5V) via SO (serial output) and SI (serial input) pins 2 and 3 of the CAT jack on the rear panel of the transceiver, at 4800 bits/s. CAT jack pinout is shown below and on page 11.

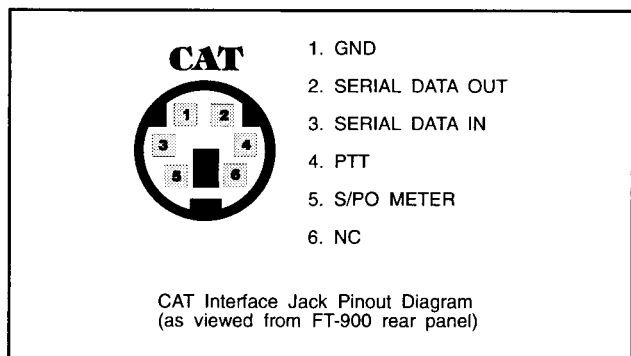

Each byte sent consists of one start bit, 8 data bits, no parity and two stop bits:

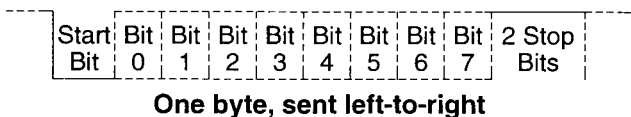

All commands sent to the transceiver must consist of *blocks* of five bytes each, with up to 200 ms between each byte. The last byte sent in each block is the *instruction opcode*, while the first four bytes of each block are arguments: either parameters for that instruction, or dummy values (to pad the block out to five bytes):

4th Arg Byte	3rd Arg Byte	2nd Arg Byte	1st Arg Byte	Opcode
-----------------	-----------------	-----------------	-----------------	--------

5-Byte Command Block, send left-to-right

There are twenty-five instruction opcodes for the FT-900, listed in the table on page 48. Notice that several instructions require no specific parameters, but every command block sent to the transceiver *must* consist of five bytes.

The CAT control program in the computer must construct the 5-byte block by selecting the appropriate instruction opcode, organizing the parameters, if any, and providing unused (dummy) argument bytes for padding (dummy bytes may have any value). The resulting five bytes are then sent, *opcode last*, to the SI serial input pin of the CAT jack on the transceiver.

Example: Tune to 14.25000 MHz;

- First determine the opcode for the desired instruction (see the CAT Commands table, page 48). These opcodes should be stored in the program so they can be looked up when the user requests the corresponding command. In this case the instruction is "Set Op Freq", so the opcode is 0Ah. Small "h"s following each byte value indicate hexadecimal (base 16) values.

- Build the four argument byte values from the desired frequency by breaking it into 2-digit blocks (BCD "packed decimal" format). Note that a leading zero is always required in the hundred's-of-MHz place (and another in the ten's-of-MHz if below 10 MHz).
- The resulting 5-byte block should look like this (again, in hexadecimal format):

Byte Value	0Ah	01h	42h	50h	00h
Content of this byte	Set Op Freq. opcode	100's & 10's of MHz	1's of MHz & 100's of kHz	10's & 1's of kHz	100's & 10's of Hz

- Send these five bytes to the transceiver, in *reverse order* from that shown above — from right-to-left (see the examples on page 47).

Data Returned From FT-900

The *Status Update*, *Read Flags* and *Read Meter* commands cause the FT-900 to report various operational and internally stored settings on the SO (serial output) line:

Status Update causes the FT-900 to return all or portions of its RAM table (up to 1941 bytes).

Read Flags obtains only the first 3 bytes (the Status Flags) from the RAM table, plus 2 extra "filler" bytes (08h and 41h),

Read Meter returns the meter deflection (0 — 0FFh) repeated in four bytes, followed by one "filler" byte (0F7h).

Each returned byte may be delayed by an interval determined by the *Pacing* command (0 to 255 ms in 1-ms steps). This delay is initially zero until the *Pacing* command is sent. This allows returned data to be read and processed by even very slow computers. However, you should set it as short as your computer will allow, to minimize the inconvenience of the delay. In the worst case, when the radio is to return all 1941 bytes of internal data, about 1.4 seconds is required with "0"-length delay selected, but almost 3 *minutes* if the maximum delay is selected!

Status Update Data Organization

The 1941 bytes of *Update* data is organized as shown on the next page. Aside from the *Read Flags* command, different portions of this data can be returned in blocks of 1, 18, 19 or 1941 bytes, depending on the parameters of the *Update* command sent by the computer. The details of these commands follow the descriptions of the data.

(A) Flag Bytes

The first 3 bytes are treated as 24 1-bit flag fields: a function is enabled (on) if a bit is set (1), and disabled (off) if reset (0). Most of the functions represented by these flags correspond to the radio display.

All 1941 Bytes of Status Update Data (Sent L-to-R)

Flags	Mem	Operating Data Record	VFO-A Data	VFO-B Data	Memory Data Records
3	1	19 bytes	9 bytes	9 bytes	19-bytes (x 100 memories=1900 bytes total)
(A)	(B)	(C)	(D)	(E)	(F)

Flags (A)

First Byte

- Bit 0: LOCK is active (= display)
- Bit 1: GEN operation (= display)
- Bit 2: SPLIT operation (= display)
- Bit 3: Memory checking (M CK) in progress
- Bit 4: Memory tuning (M TUNE) activated
- Bit 5: MEM operation (= display)
- Bit 6: VFO B in use for transmit or receive
- Bit 7: VFO A or B operation (= display)

Second Byte

- Bit 0: PTT line closed by CAT command
- Bit 1: Memory scanning is paused
- Bit 2: Scanning in progress (paused or not)
- Bit 3: Not used
- Bit 4: Not used
- Bit 5: Antenna Tuner tuning (WAIT)
- Bit 6: High SWR (= display)
- Bit 7: FAST tuning/scanning rate is activated

Third Byte

- Bit 0: ATU Operation (reduce power to 10W)
- Bit 1: ATU Operation (reduce power to 50W)
- Bits 2 -4: not used
- Bit 5: Antenna TUNER tuning (panel LCD)
- Bit 6: Not used
- Bit 7: Transmission in progress (PTT closed)

Memory Channel Number (B)

The 4th byte of Update data contains a binary value between 01h and 64h (100 decimal), indicating the current memory number (or the last-selected memory, if operating on a VFO). note: P1=5Bh, P0=64h.

19-Byte Operating Data Records (C)

The Memory Number is followed by a 19-byte record defining current operating conditions. That is, the two VFOs if operation is on a VFO, or the front and rear halves of the current memory if operation is on a memory. This record consists one byte of *Memory Status* flags followed by two 9-byte *VFO/Memory Data* records:

19-Byte Data Record Format

1 byte	9 bytes	9 bytes
Memory Status Flag	VFO-A or Memory Front Half	VFO-B or Memory Rear Half

Memory Status Flags (1 Byte)

This byte is at the head of every 19-byte Data Record. Bits 0 through 5 are not used. Bit 6 is set if the SPLIT function is active on the memory, and Bit 7 is set if the memory is blanked.

VFO/Memory Data Record (9 Bytes)

The structure of a 9-byte VFO/Memory Data record is detailed in the table below. Each byte in the table is identified by its offset from the start (base address) of the record, since the same 9-byte record format is also used elsewhere.

9-Byte VFO/Memory Data Record Format

Offset	Contents & Format of Byte Field
0	BPF selection: 0 to 09 binary
1 - 3	Bytes 1 - 3: Base frequency in 10's of Hz (w/o clar/rpt offset). Binary value in range 10000 - 3000000. Byte 1 is MSB.
4 - 5	Clarifier Offset FC19h-03E7h
6	Mode: 0=LSB, 1=USB, 2=CW, 3=AM, 4=FM
7	CTCSS Encode (tone = 00-20h) see the table on next page.
8	VFO/Memory Operating Flags (see below)

VFO/Memory Operating Flags

Each bit in this field signifies a state unique to one VFO or half-memory.

- Bit 0: frequency not 100 Hz multiple (AM or FM operation)
- Bit 1: SSB mode (0: LSB, 1:USB)
- Bit 2: Memory set to SKIP when scanning
- Bit 3: - Repeater Shift (for FM only)
- Bit 4: + Repeater Shift (for FM only)
- Bit 5: Clarifier active
- Bit 6: Current mode is AM NARrow
- Bit 7: Current mode is CW NARrow

VFO-A and VFO-B Data (D) & (E) 9 bytes each

After the 19-byte Data Record for current operation is sent, two 9-byte VFO/Memory Data Records are sent; one for each VFO. The format of each of these records is the same as described above, and in fact, when operating on a VFO, the values in these records are identical to the two 9-byte records included in the 19-byte Data Record for current operation.

100 Memory Data Records (F)

After the two 9-byte records for the VFOs, 100 19-byte Data Records are sent: one for each memory, beginning with memory 01. Each memory data record is constructed as described above for the 19-byte Data Records.

Status Update Data Selection

The 1st and 4th parameters of the Status Update command allow selection of different portions of the Status Data to be returned, as follows ("U" is the 1st parameter, "CH" is the 4th):

Parameters	Data Returned	Reference (see previous page)
U=0	All 1941 bytes	A
U=1	Memory Number	B
U=2	19-Byte Operating Data Record	C
U=3	18-Byte VFO-A & VFO-B Data	D & E
U=4 CH=1-64h	19-Byte Mem Data Record for mem CH	F

Note that, in most cases, you will only need to read the 19-byte Operating Data Record (with the first parameter = 2), since all other CAT commands affect only this data (except **V-M** and *Memory Scan Skip*).

Read Flags Data

The *Read Flags* command retrieves the (first) 3 Flag Bytes of the Status Data. The transceiver responds to the *Read Flags* command by returning the Flag Bytes described on the preceding page, plus two bytes with the constant values of 08h and 41h (in that order), as shown here:

1st Flag Byte	2nd Flag Byte	3rd Flag Byte	Dummy (08h)	Dummy (41h)
---------------	---------------	---------------	-------------	-------------

Read S/PO Meter Data

Sending the *Read Meter* command causes the transceiver to return a digitized meter deflection indication, between 0 and 0FFh (in practice, the highest value returned will be around 0F0h). Four copies of this value are returned, along with one constant byte (0F7h), as follows:

Meter Byte	Meter Byte	Meter Byte	Meter Byte	0F7h
------------	------------	------------	------------	------

During reception, the signal strength deflection is returned. During transmission, the power output level deflection is returned.

CTCSS Tone Codes (hex) & Frequencies (Hz)

Frequency	Code	Frequency	Code
67.0	00	146.2	11h
71.9	01	151.4	12h
77.0	02	156.7	13h
82.5	03	162.2	14h
88.5	04	167.9	15h
94.8	05	173.8	16h
100.0	06	179.9	17h
103.5	07	186.2	18h
107.2	08	192.8	19h
110.9	09	203.5	1Ah
114.8	0Ah	210.7	1Bh
118.8	0Bh	218.1	1Ch
123.0	0Ch	225.7	1Dh
127.3	0Dh	233.6	1Eh
131.8	0Eh	241.8	1Fh
136.5	0Fh	250.3	20h
141.3	10h		

Writing Programs

Coding Examples

Although Yaesu Musen Company cannot offer to provide complete CAT control programs (owing to the variety of incompatible computers used by our customers), the following are a few examples of critical CAT I/O functions, in BASIC programming language. Note that all variations of BASIC may not support some of the commands, in which case alternate algorithms may need to be developed to duplicate the functions of those shown.

Sending a Command

After “opening” the computer’s serial port for 4800-baud, 8 data bits and 2 stop bits with no parity, as i/o device #2, any CAT command may be sent. However, if you determine that your computer may need extra time to process data returned from the transceiver, you should send the *Pacing* command first. Here is an example of the *Pacing* command setting a 2-ms delay:

```
PRINT #2,  
CHR$(0);CHR$(0);CHR$(0);CHR$(2);CHR$(&HE);
```

Notice that the instruction opcode is sent last, with the first (MSB) parameter sent just before it, and the LSB parameter (or dummies) sent first. The parameters are sent in the reverse order from that in which they appear in the CAT Commands table. Also note that in this and the following examples, we are sending zeros as dummy bytes; although this is not necessary. If you decide to send commands through a 5-byte array, the values of the dummy parameters need not be cleared.

For example, the following command could be used to set the frequency of the display to 14.25000 MHz:

```
PRINT #2, CHR$(&H00); CHR$(&H50);  
CHR$(&H42); CHR$(&H01); CHR$(&HA);
```

Notice here that the BCD values can be sent just by preceding the decimal digits with “&H” in this example. However, in an actual program you may prefer to convert the decimal frequency variable in the program to an ASCII string, and then to convert the string to characters through a lookup table.

If you send a parameter that is out of range for the intended function, or not among the specified legal values for that function, the FT-900 should do nothing. Therefore, you may wish to alternate your sending regular commands or command groups with a *Read Flags* or an *Update* command, allowing the transceiver to let the computer know if everything sent so far has been accepted and acted upon as expected.

Bear in mind that some commands specify “binary,” as opposed to BCD-formatted parameters. You can send binary parameters without going through the character/hex string conversion process. For example, the CH parameter in the Command table is binary.

You could have the FT-900 recall memory 29 (decimal) by the following:

```
PRINT #2,  
CHR$(0);CHR$(0);CHR$(0);CHR$(29);CHR$(2);
```

Reading Returned Data

The reading process is easily done through a loop, storing incoming data into an array, which can then be processed after all expected bytes have been read into the array. To read the meter:

```
FOR I=1 TO 5  
  MDATA(I) = ASC(INPUT$(1,#2))  
NEXT I
```

Recall from above that the meter data consists of four identical bytes, followed by a filler byte, so we really only need to see one byte to get all of the information this command offers. Nevertheless, we must read all five bytes (or 1, 18, 19 or 1941, in the case of the Update data). After reading all of the data, we can select the bytes of interest to us from the array (MDATA, in the above example).

CAT Commands

Legend:

Send all commands in REVERSE order from that shown! Commands that duplicate a front panel button are named with all caps. Parameter variables are named to reflect their format: eg., "CH" indicates a memory number, from 1 to 64h (1 to 100 decimal).

"—" indicates a padding byte. Value is unimportant, but it must be present to pad the block out to five bytes.

Opcodes are listed in both hex and decimal format for convenience - only one opcode byte can actually be sent.

#	Command	Opcode		Parameter Bytes				Parameter Description
		hex	(dec)	1	2	3	4	
1	SPLIT	01	1	T	-	-	-	Switch Split tx/rx operation ON (T=1) and OFF(T=0)
2	Recall Memory	02	2	CH	-	-	-	Recalls memory number CH: 1 to 64h corresponding to memories 1 through P0
3	V ► M	03	3	CH	P2	-	-	Code to display memory CH (P2=0), Hide CH (P2=1) or Unhide CH (P2=2)
4	LOCK	04	4	P	-	-	-	Tuning knob or panel lock/unlock(P=1/ 0)
5	A/B	05	5	V	-	-	-	Select operation on VFO A (V=0) or VFO B (V=1)
6	M ► V	06	6	CH	-	-	-	Copy memory CH (1 to 64h) to last-used VFO
7	▲UP	07	7	00h	S	-	-	Step current display up 100 kHz (S=0) or 1 MHz (S=1)
8	▼DOWN	08	8	00h	S	-	-	same as UP, but steps down
9	CLAR	09	9	C	C1	C2	C3	Clarifier on/off/freq. set (C=1/ 0/FFh) C1-3=clarifier offset frequency in BCD format.
10	Set Op Freq.	0Ah	10	F1	F2	F3	F4	New operating frequency in F1 - F4, in BCD format: see text for example
11	MODE	0Ch	12	M	-	-	-	M values: LSB=0, USB=1, CW-wide=2, CW-nar=3, AM-wide=4, AM-nar=5, FM= 6 or 7
12	HAM/GEN	0Dh	13	HG	-	-	-	Select HAM/GEN stepping functions (H/G=0/1)
13	Pacing	0Eh	14	N	-	-	-	Add N-millisecs (0-FFh) delay between bytes of all data returned from radio
14	PTT	0Fh	15	T	-	-	-	Transmitter on (T=1) or off (T=0)
15	Status Update	10h	16	U	-	-	CH	Instructs the radio to return 1, 18, 19 or 1941 bytes of Status Update data. CH is significant only when U=0-4. See text on page 46
16	TUNER	81h	129	T	-	-	-	Switch antenna tuner on (T=1) or off (T=0)
17	Tuner start	82h	130	-	-	-	-	Start antenna tuner
18	Repeater Offset	84h	132	R	-	-	-	Select simplex (R=0), -shift (R=1), or +shift (R=2)
19	VFO-A = VFO-B	85h	133	-	-	-	-	Copy displayed VFO(A or B) data to other VFO (B or A, resp.)
20	Memory Scan Skip	8Dh	141	CH	T	-	-	For memory CH (1 - 64h), skip (T=1) or include (T=0) in scanning
21	Step Op Freq.	8Eh	142	D	-	-	-	Step operating freq up (D=0) or down (D=1)
22	Encoder Frequency Select	90h	144	S	-	-	-	(S=00 ~ 20h)
23	Read S/PO Meter	0F7h	247	-	-	-	-	Instructs radio to return digitized meter indication (4 repeated bytes, and 0F7h)
24	Repeater Offset	0F9h	249	00h	S2	S3	S4	Set offset for RPT shifts, valid values are 0 - 500,000Hz (BCD format, in S2 - S4). Parameter 1 must be zero, S2 must be 0, 1 or 2. S3 is 1's & 10's of kHz, S4 is 10's & 100's of Hz.
25	Read flags	0FAh	250	-	-	-	-	Instructs radio to return the 24 1-bit Status Flags (5 bytes, see page 46)

Front Panel Controls

Press this button momentarily to turn the transceiver on, and hold it (>1/2 sec.) to turn it off. To avoid switching spikes, make sure it is off when you turn the DC power source (AC power supply) on or off. In a mobile installation, the transceiver should be off when starting or stopping the engine.

Pressing this button momentarily puts the antenna tuner in line (**TUNED** displayed). reception is not affected. Holding the button (>1/2 sec.) activates the transmitter while the tuner rematches the antenna for minimum SWR. The resulting settings are stored in the antenna tuner's 31 memories, for automatic recall later. See page 20.

Press this button to select the meter function available on the display. Three combinations are as follows:

1. S-meter/RF power
2. S-meter/RF power & ALC
3. S-meter/RF power & SWR

This 8-pin modular jack accepts the MH-31A8J Hand Scanning Microphone. Proper microphone input impedance is 600 ohms.

Some of these buttons have an internal LED indicator to show when the function is activated.

PROC activates the speech processor in the SSB and AM modes. See page 21.

ATT If the IPO function is on and the band is noisy or very strong signals are present, press this button to insert a 12-dB attenuator in the front end to protect the receiver from overload.

IPO bypasses the receiver RF amplifier, providing the widest dynamic range. See page 18 for details.

NB press this to reduce pulse-type interference. Leave off if audio distortion occurs.

SPLIT This activates split frequency transceive operation. The displayed frequency is used for reception, and the other VFO or rear half of the memory for transmission. The **SPLIT** indicator is lit while this function is active.

HAM/GEN This button determines the function of the **DOWN/UP** buttons when receiving on a VFO or retuned memory: GEN steps are 100 kHz, and HAM steps are from one amateur band to the next.

The display indicates the operating frequency, memory number and special states. The meter indicates the selected parameter during transmission (see **METER** switch), and signal strength in S-units during reception (below the frequency). Details are on the rear page of the fold-out.

These four momentary buttons select the operating mode, also indicated at the top of the display

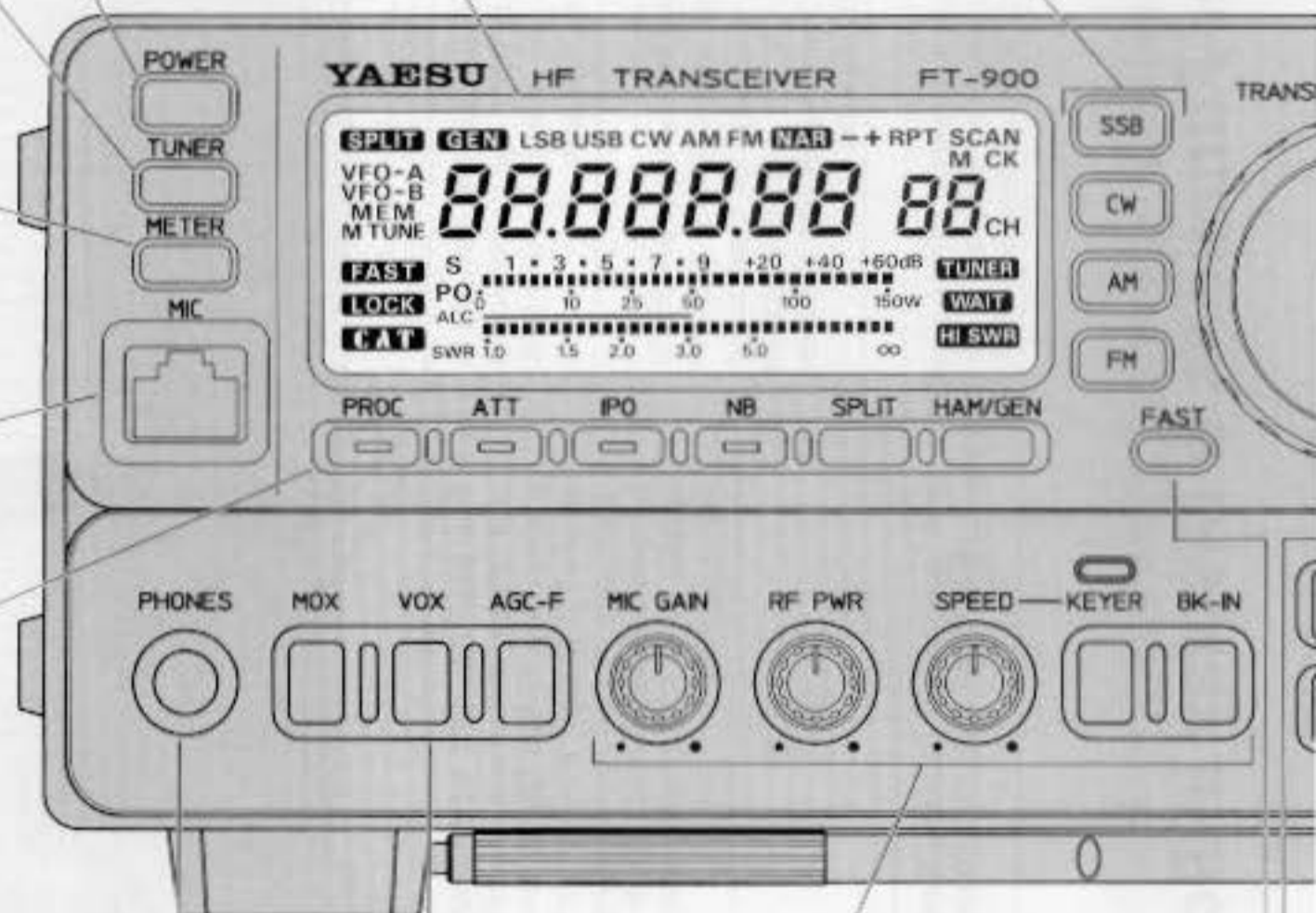

This 3.5-mm, 3-contact jack accepts either monaural or stereo headphones with a 2- or 3-contact plug. When a plug is inserted, the loudspeaker is disabled. Audio is supplied to both channels of a stereo headphone.

MOX This is used to manually key the transmitter. It must be in the undepressed (■) position for reception.

VOX Enables automatic voice-actuated transmitter switching in voice modes. Related controls are on the rear panel, and operation is described on page 21.

AGC-F sets the receiver Automatic Gain Control decay time for fast recovery, which can improve CW reception and fast-fading (QSB) SSB signals.

MIC GAIN adjusts the microphone input level for SSB and AM transmission.

RF PWR sets transmitter output power in all modes. The adjustment range is from less than 10 to 100 watts (5 to 25 watts AM).

SPEED This control adjusts the speed of the internal electronic CW keyer, when the **KEYER** switch is depressed.

KEYER This push button switch activates the internal electronic CW keyer. In the undepressed position (■), the internal keyer is disabled. Keyer operation is described on page 22.

BK-IN Pressing this button turns full break-in operation (CW QSK) on and off.

When VFO button is pressed...

The BU green squelch turns TRAN...

TRANS

For fast rotating the ▲U increase 1 on page When fa appears in function "press-a holding ceiver o

This bu change: can still can cha of just th

When receiving on a VFO, this button toggles operation and display between VFOs A and B. On a memory, it toggles front and rear halves. Holding this button for 1/2-second copies the contents of the display to the other VFO. Previous contents of the non-displayed VFO is overwritten (*lost!*).

The **BUSY** LED glows green when the squelch is open, and turns red during **TRANSMIT**.

This button toggles operation between a memory and a VFO. Either **VFO- A** (or **-B**), or **MEM** is displayed to indicate the current selection. If a displayed memory has been retuned, pressing this button once returns the display to the original memory contents, and pressing it again returns to the last-used VFO.

Pressing this button momentarily displays the contents of the currently selected memory channel for three seconds. When receiving on a VFO or a retuned memory, holding this button for 1/2-second writes the current operating data to a selected memory. Two beeps sound, and any previous data in the memory is overwritten. Also, pressing and holding this button after recalling a memory (without retuning) causes the memory to be "masked." Repeat to unmask the memory.

Pressing this button momentarily displays the contents of the currently selected memory channel for three seconds. Holding this button for 1/2 second copies all data from the memory to the VFOs, as two beeps sound. Previous data in the VFOs is overwritten. See page 28.

The inner **AF** gain control adjusts the volume of the receiver in the speaker or headphones.

The outer **SQL** control sets the signal threshold at which receiver audio is muted (and the **BUSY** LED turns off), in all modes. This control is normally kept fully CCW, except when scanning, and during FM operation. Scanning stops when the squelch is open. See page 29.

Pressing either of these buttons momentarily steps the operating frequency down or up one ham band, or 100 kHz (if receiving in GEN mode), respectively. Pressing **FAST** with one of these buttons steps down or up 1 MHz if receiving in GEN mode. Continue holding either button for repeated stepping.

The inner **NOTCH** control adjusts the IF notch frequency when activated by the button/LED next to the label. In modes other than AM and FM, the outer **SHIFT** control offsets the IF passband center frequency from the displayed frequency when turned away from the 12-o'clock position.

This knob tunes the clarifier offset frequency up to ± 9.99 kHz, when activated by the **CLAR** button/LED above and to the left of it. Operating details are on page 25.

For fast tuning, press this button while rotating the tuning knob or pressing the **▲UP** or **▼DOWN** button, to increase the tuning rate. See the table on page 16 for all available steps. When fast tuning is active, "FAST" appears in the display. You can set the function of this button to be either "press-and-hold", or toggle on/off, by holding it while switching the transceiver on.

These buttons provide one-touch band selection, or digital frequency entry. Normally, pressing one of the button selects the corresponding amateur band (or band used for general coverage reception with the **GEN** button). However, if the **ENT** key is pressed first, the buttons enter the digits of the desired operating frequency directly.

This button toggles locking of the tuning knob to prevent accidental frequency changes. "LOCK" appears at the bottom left of the display window when locked (the knob can still be turned, but it does nothing). Press again to re-enable the tuning knob. You can change the function of this button to lock most of the controls and buttons, instead of just the tuning knob, by holding the button while switching the transceiver on.

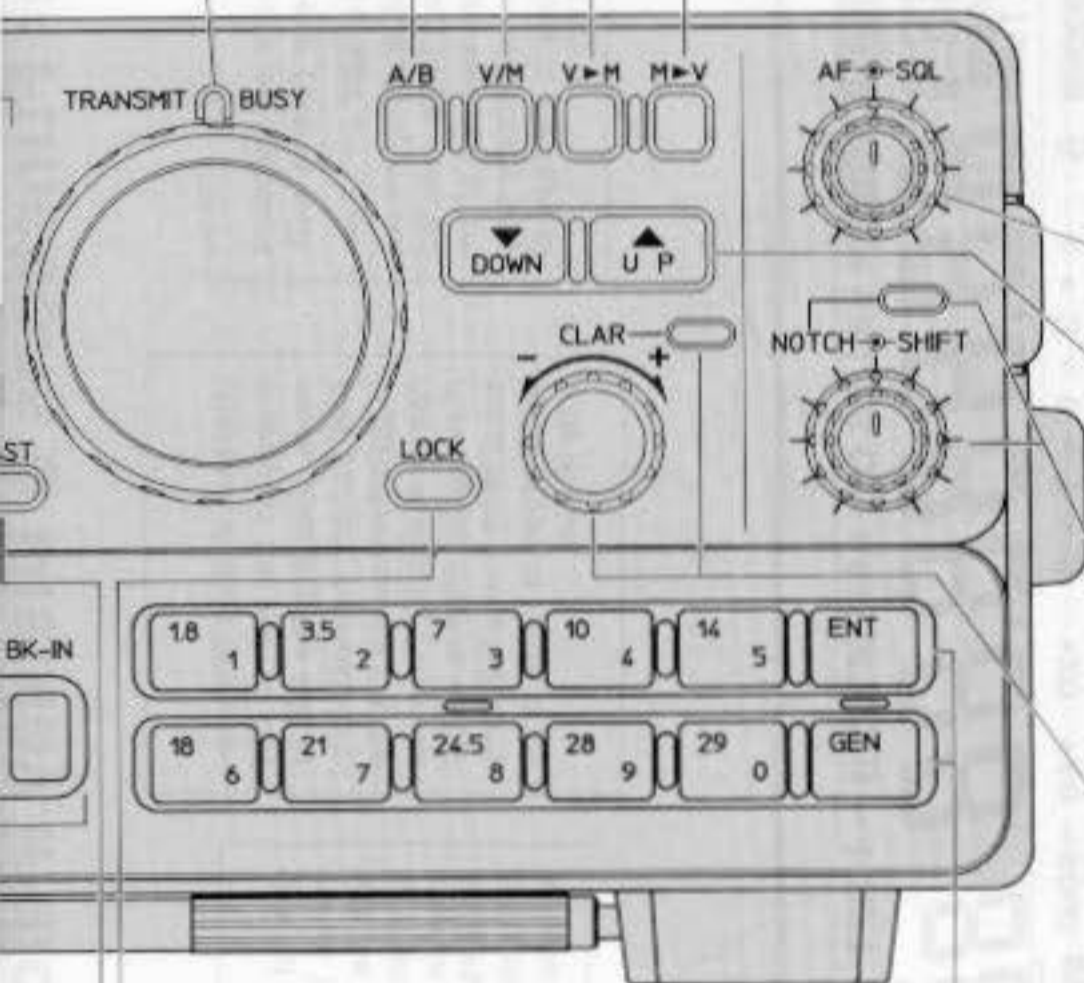

Meter Functions & Display Indications

These indicators appear when their respective functions are active: split transceive (page 25), General coverage (100-kHz) **▼DOWN/UP▲** stepping (page 15).

One of these four indicators shows the current VFO/memory state selected by the **A/B**, **V/M**, **V►M** and **M►V** buttons, or when retuning a memory (**M TUNE**).

This is the current operating frequency, with decimals at the MHz and kHz positions. The rightmost large digit is 10's of Hz. The displayed frequency changes when you transmit with either clarifier offset, split transceive or repeater offset enabled.

These three indicators appear when the respective functions are active:

- FAST**-fast tuning rate is active
- LOCK**-front panel tuning knob or buttons are locked
- CAT**-External computer control of transceiver is active

One of these indicators appear (along with **NAR** or **RPT + -**, if enabled) showing the operating mode selected by pressing one of the four momentary-type buttons to the right of the LCD.

(**NAR**row IF filter) While operating in the **AM** or **CW** mode, pressing the **AM** or **CW** button, respectively, toggles this indicator and the narrow IF filter for that mode (CW narrow requires an optional filter). Press the same button again to return to the wide IF filter.

One of these segments lights along with the **RPT** indicator when the repeater function is activated in the **FM** mode, indicating the direction of repeater offset.

(Memory scan skip) This indicator disappears when displaying a memory that has been selected to be skipped during memory scanning (page 29).

This indicator blinks after pressing either the **M►V** or **V►M** button, to indicate that Memory Checking is active (**M CK** blinks in the display). While it is blinking, you can press the **▼DOWN/UP▲** buttons to check the contents of memories, without affecting operation. Wait 3 seconds and Memory Checking stops. See page 28.

These two small digits display the memory number when operating on a memory or from the VFO. You can turn these digits off for VFO operation by holding the **V►M** button while turning the transceiver on.



METER FUNCTIONS

During reception, the top "**S**" scale indicates incoming signal strength in S-units at the left end of the scale, and in dB above S-9 at the right end. When transmitting, the second, "**PO**" scale indicates transmitter power output, in watts. This scale is calibrated to be most accurate when the antenna impedance is 50-Ω. For the "Peak-Hold" meter feature, press and hold the **METER** button while turning on the transceiver.

The middle "**ALC**" scale indicates transmitter Automatic Level Control voltage when selected by the **METER** button. The position and movement of the segments give a good indication of transmitter performance. This meter function is important when setting the **MIC GAIN** control for SSB modes. See the Transmitting instructions beginning on page 20.

The "**SWR**" scale indicates the standing wave ratio at the antenna jack, as a ratio of forward to reflected power, when selected by the **METER** button. A perfectly matched antenna should give no deflection. If the SWR is above 3:1, the antenna requires matching.

Antenna Tuner Unit Indicators

The **TUNER** indicator comes on when the ATU is activated and in line.

WAIT appears while the automatic antenna tuner is seeking an impedance match with the antenna. It also flashes each time the main microprocessor sends frequency update data to the tuner microprocessor (while you tune).

The **HI SWR** indicator appears when the automatic antenna tuner detects an abnormally high SWR that it cannot match.

Connection Diagram

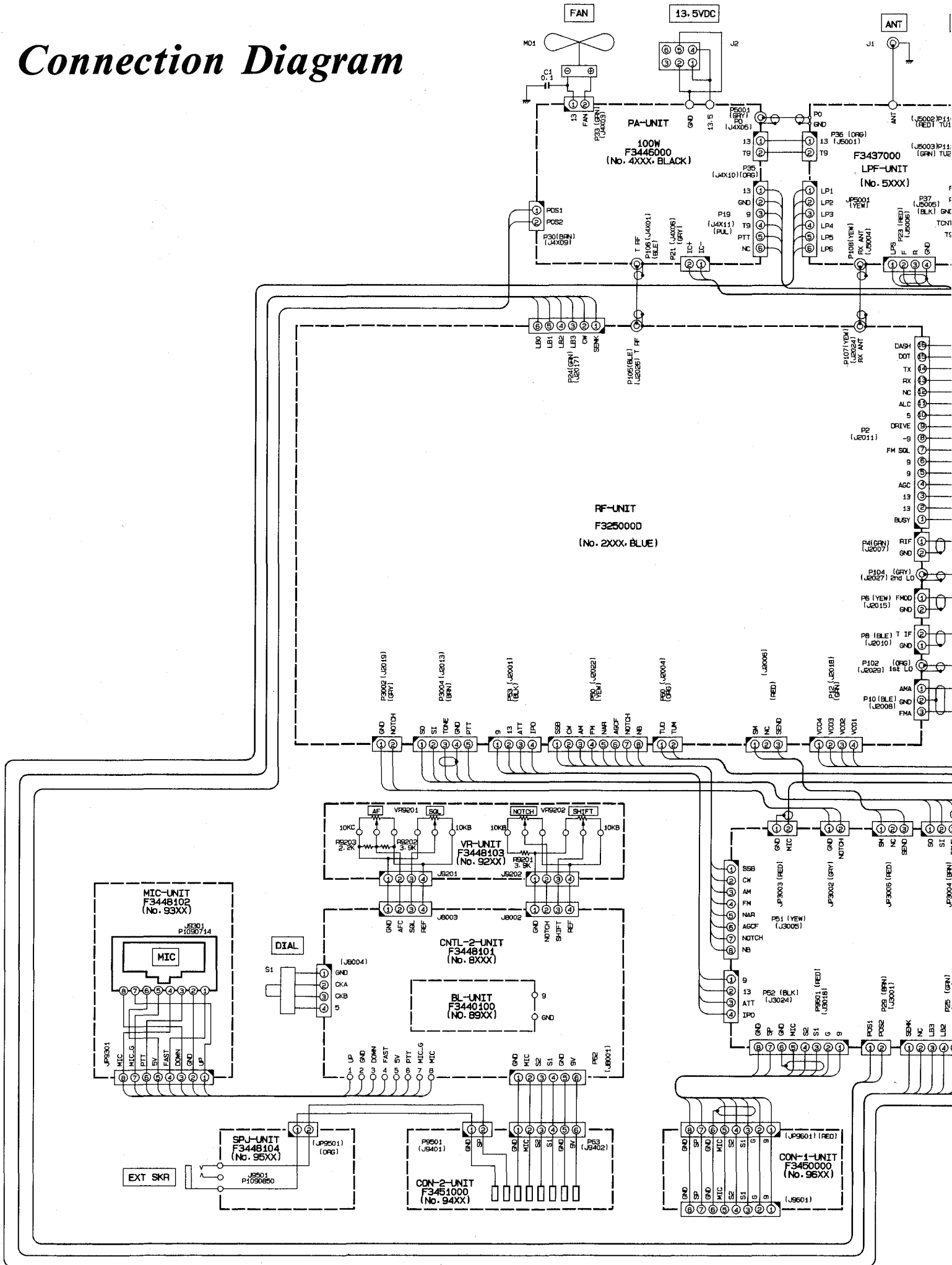

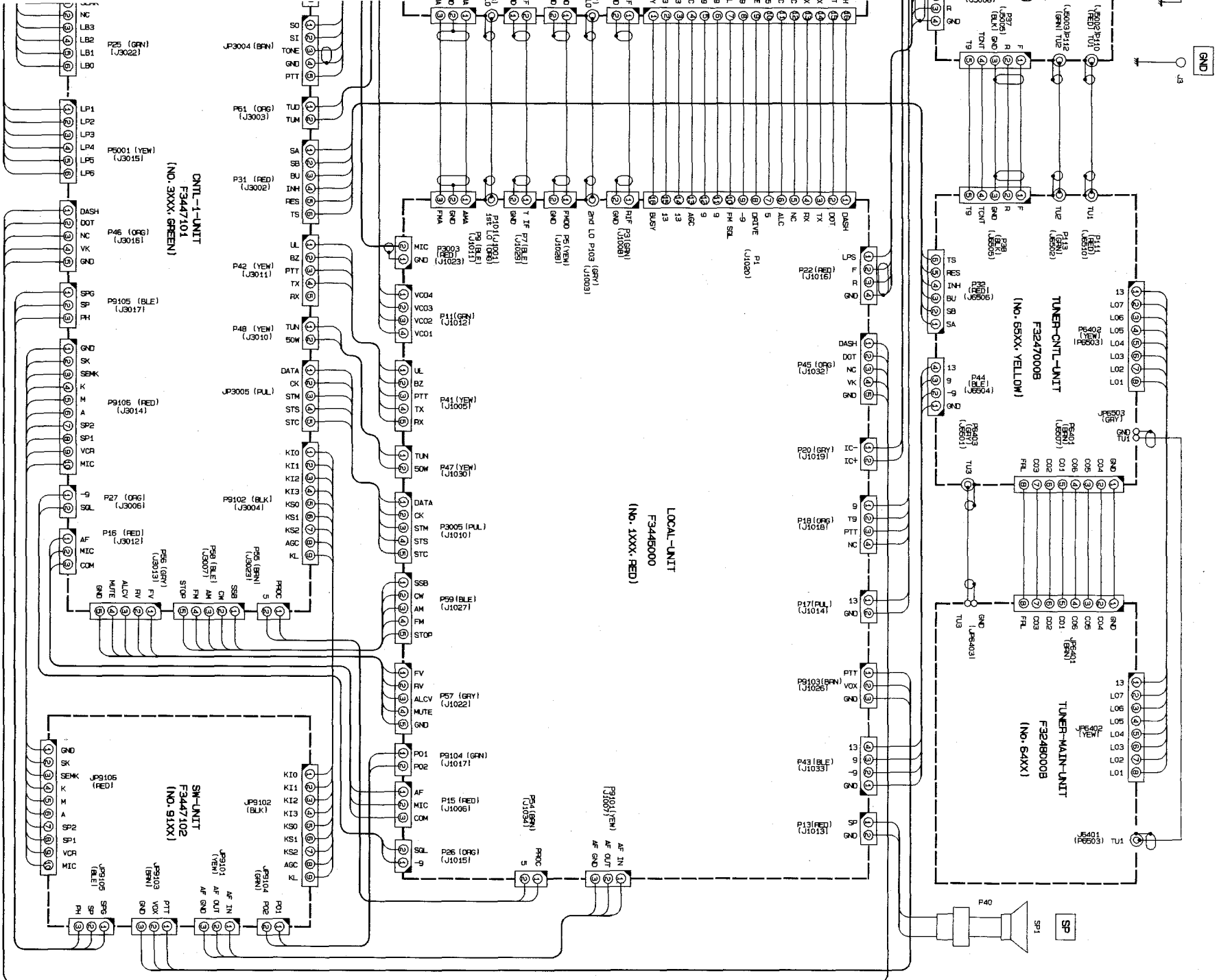

FT-900

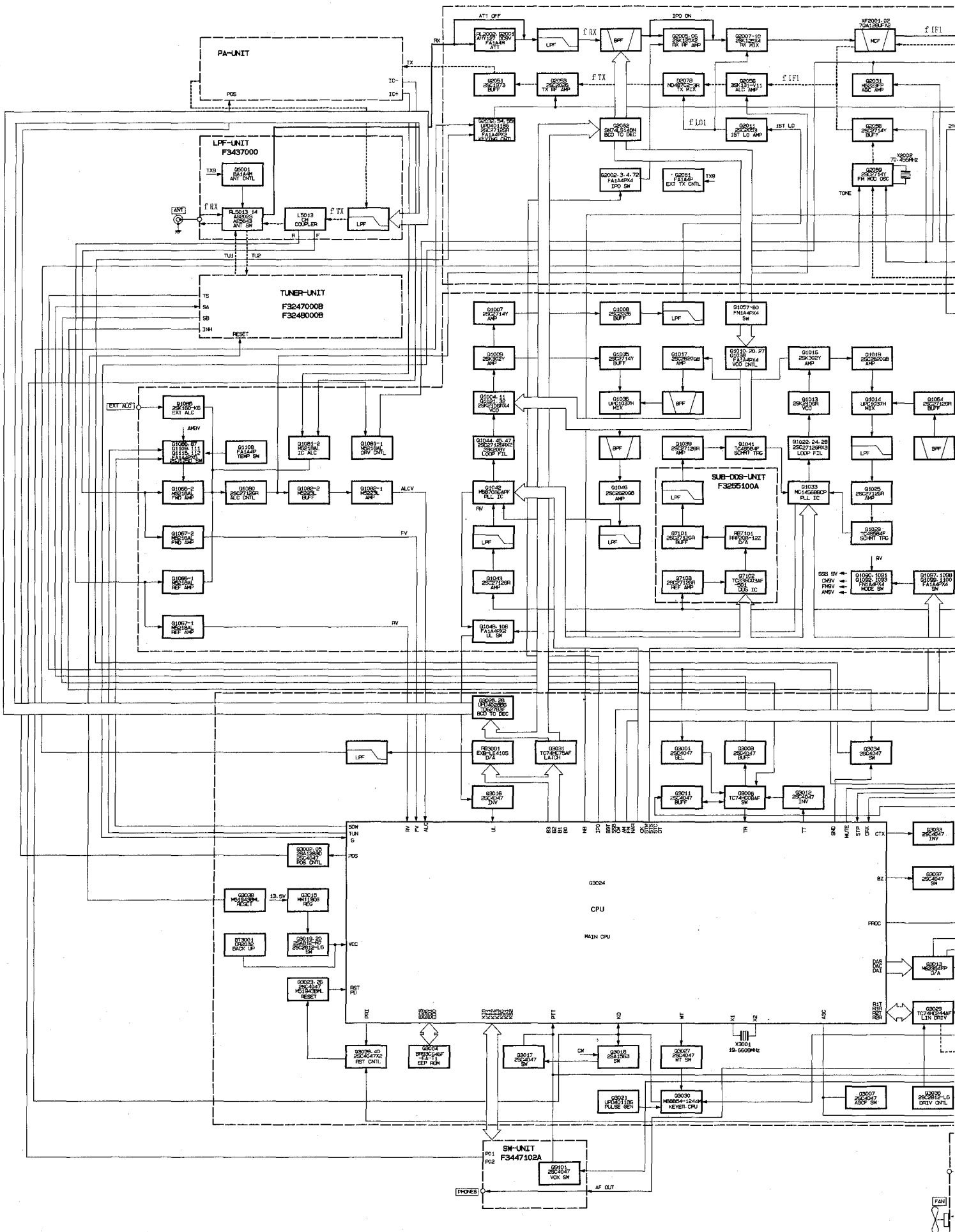

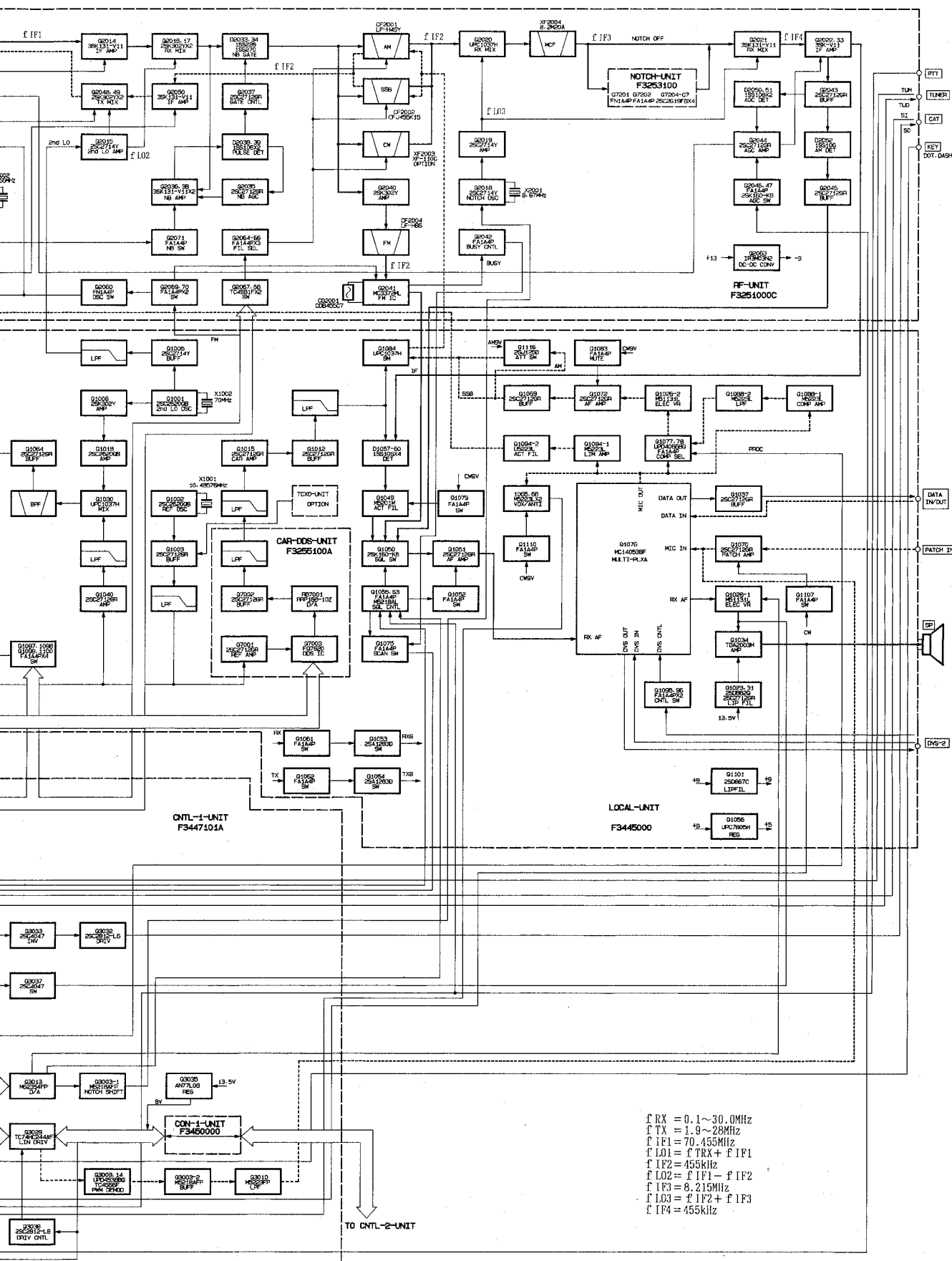

$f_{RX} = 0.1 \sim 30.0\text{MHz}$
 $f_{TX} = 1.9 \sim 28\text{MHz}$
 $f_{IF1} = 70.455\text{MHz}$
 $f_{LO1} = f_{TRX} + f_{IF1}$
 $f_{IF2} = 455\text{kHz}$
 $f_{LO2} = f_{IF1} - f_{IF2}$
 $f_{IF3} = 8.215\text{MHz}$
 $f_{LO3} = f_{IF2} + f_{IF3}$
 $f_{IF4} = 455\text{kHz}$

RX LINE ———→
 TX LINE ———→
 COMMON LINE ———→

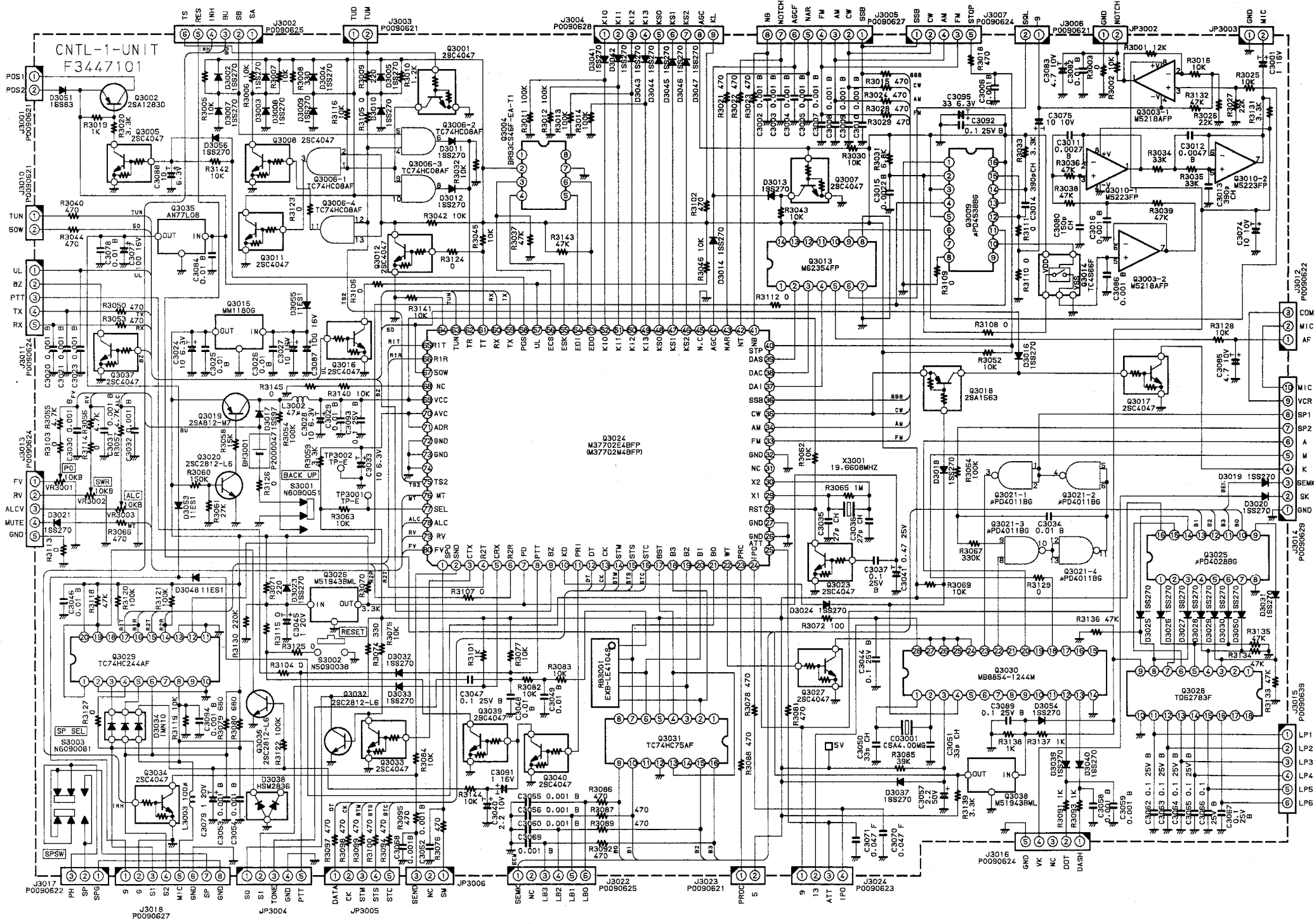

CNTL-1-UNIT
F3447101

33024
N37702E4BFP
(M37702M45FP)

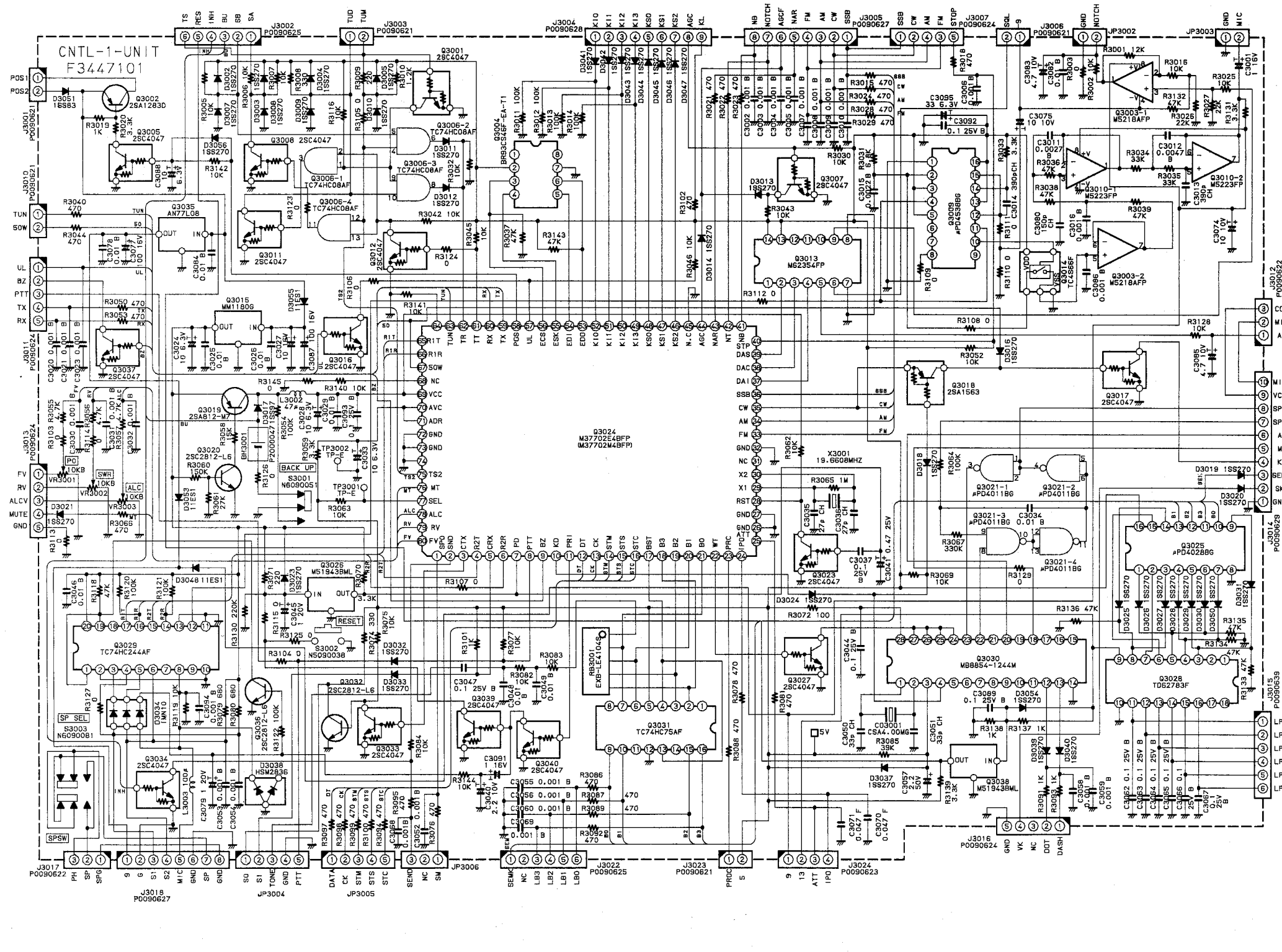

CNTL-1-UNIT
F3447101

33024
N37702E4BFP
(M37702M45FP)

LPF-UNIT
F3437000

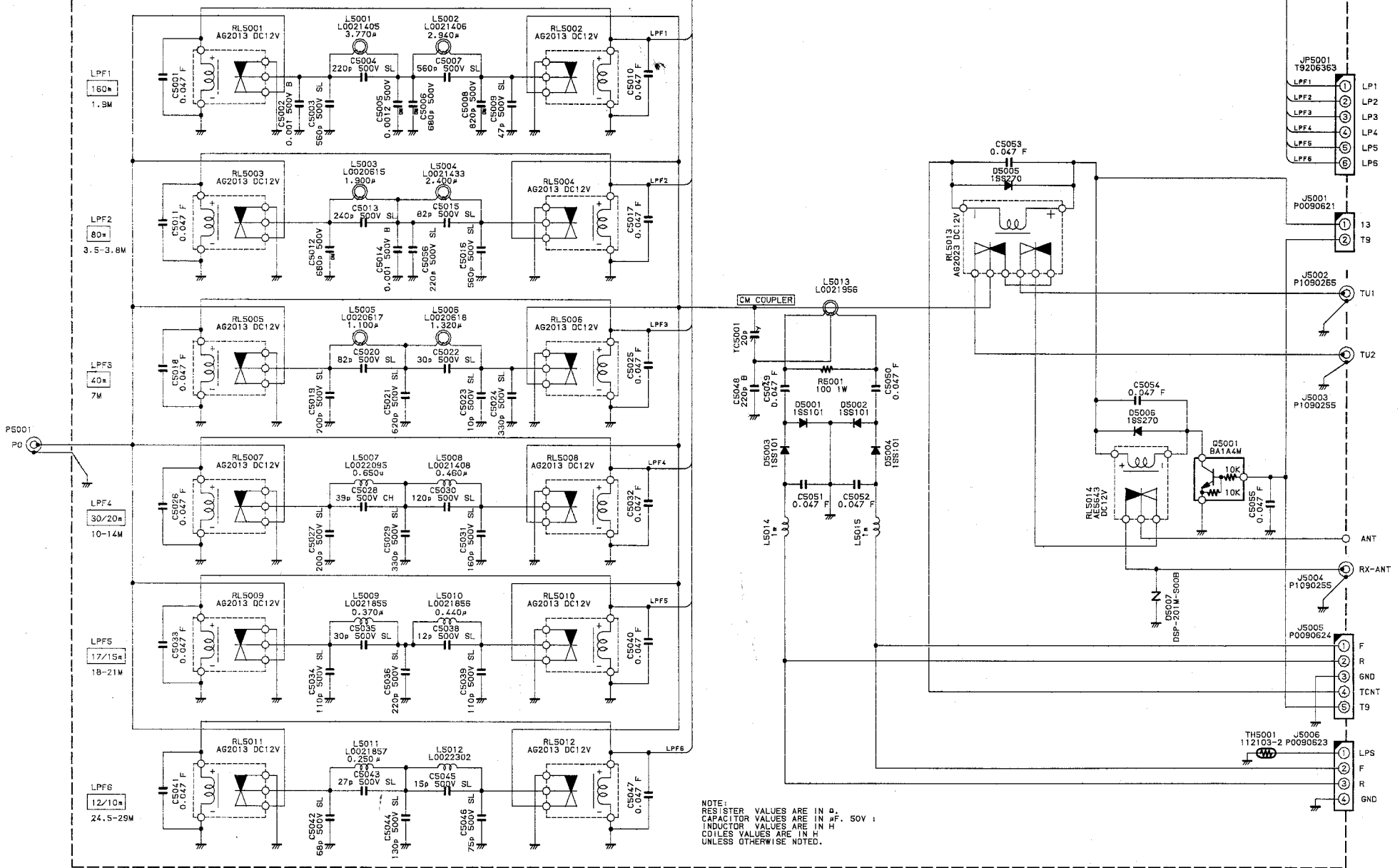

NOTE:
RESISTOR VALUES ARE IN Ω.
CAPACITOR VALUES ARE IN μF. 50V ±
INDUCTOR VALUES ARE IN μH
COILS VALUES ARE IN H
UNLESS OTHERWISE NOTED.

TUNER-MAIN UNIT F3248000B

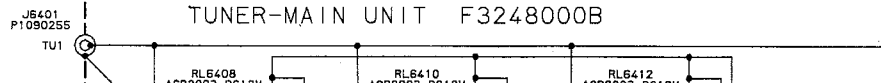

J6401
P1090255

TUNER-MAIN UNIT F3248000B

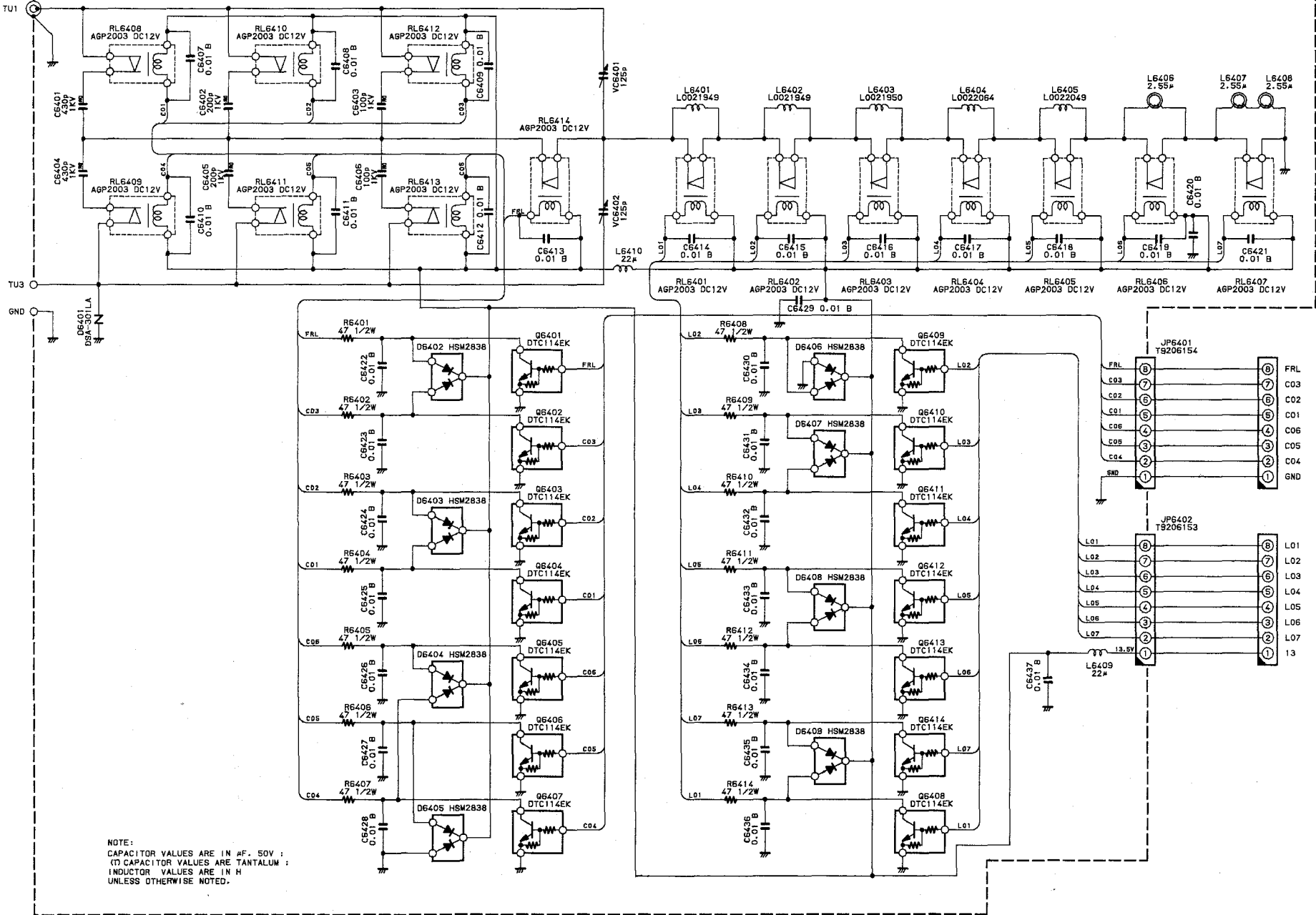

NOTE:
CAPACITOR VALUES ARE IN μ F. 50V
(T) CAPACITOR VALUES ARE TANTALUM;
INDUCTOR VALUES ARE IN H
UNLESS OTHERWISE NOTED.

NOTCH-UNIT

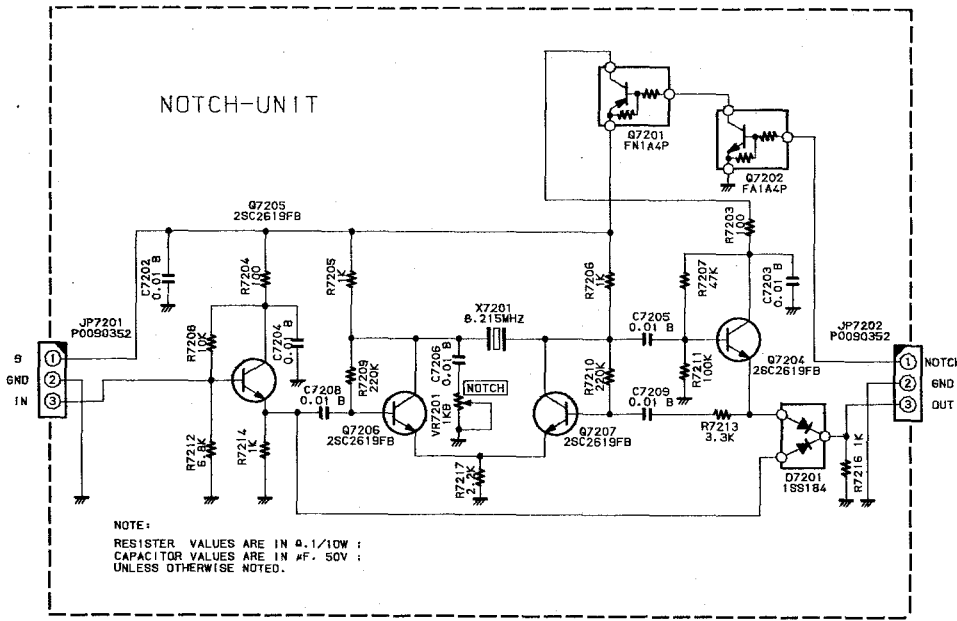

NOTE:
RESISTOR VALUES ARE IN Ω, 1/10W ;
CAPACITOR VALUES ARE IN μF, 50V ;
UNLESS OTHERWISE NOTED.

SUB-DDS-UNIT F3255100A

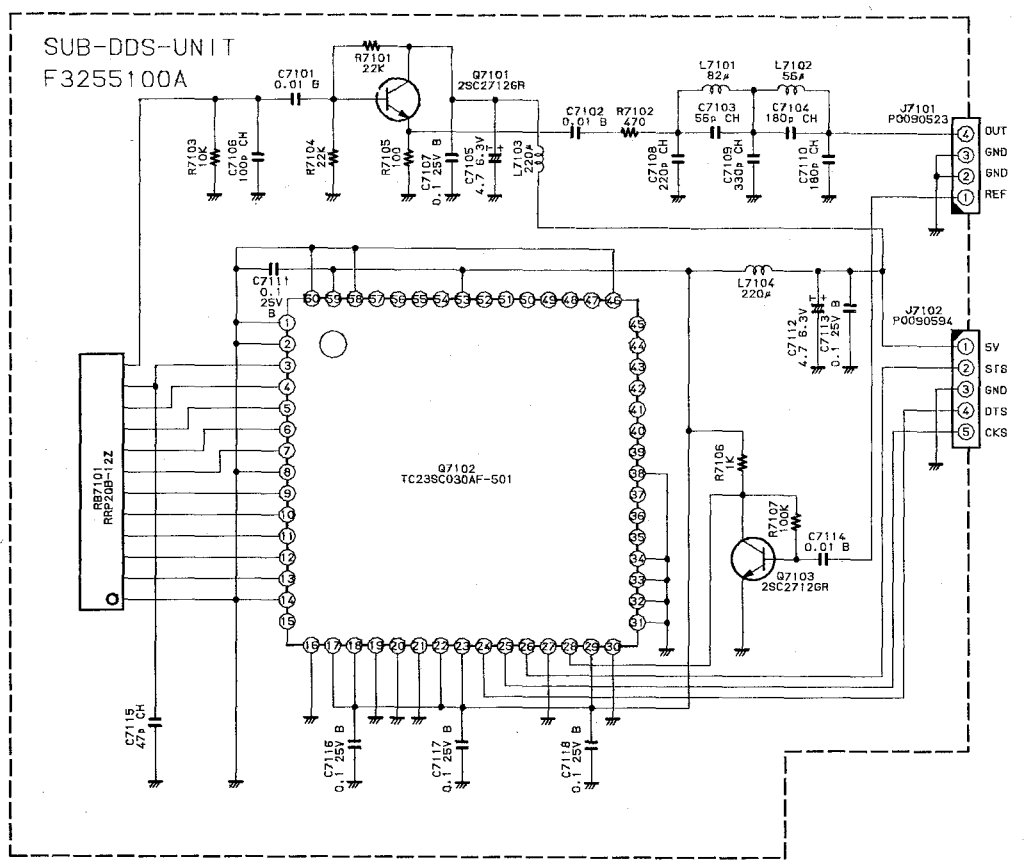

CAR-DDS-UNIT F3255100A

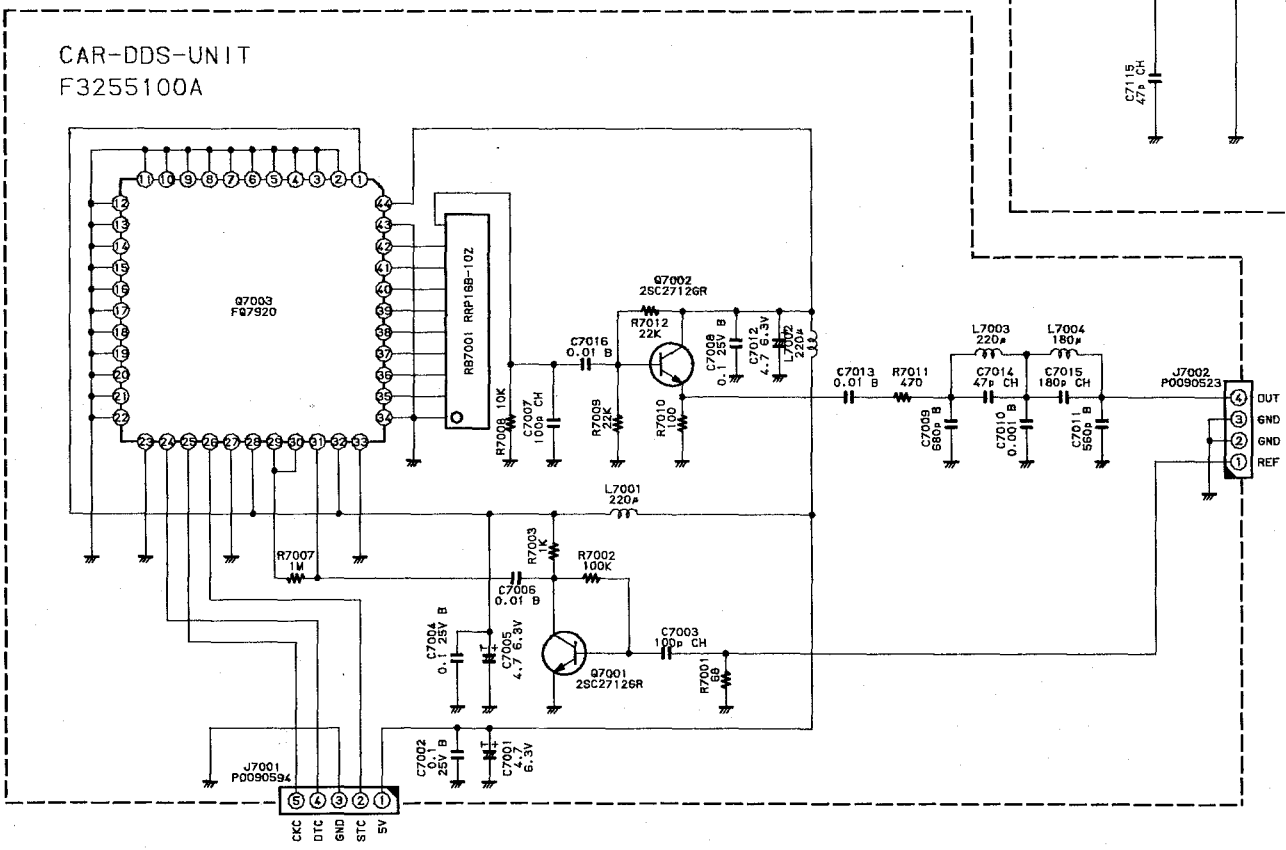

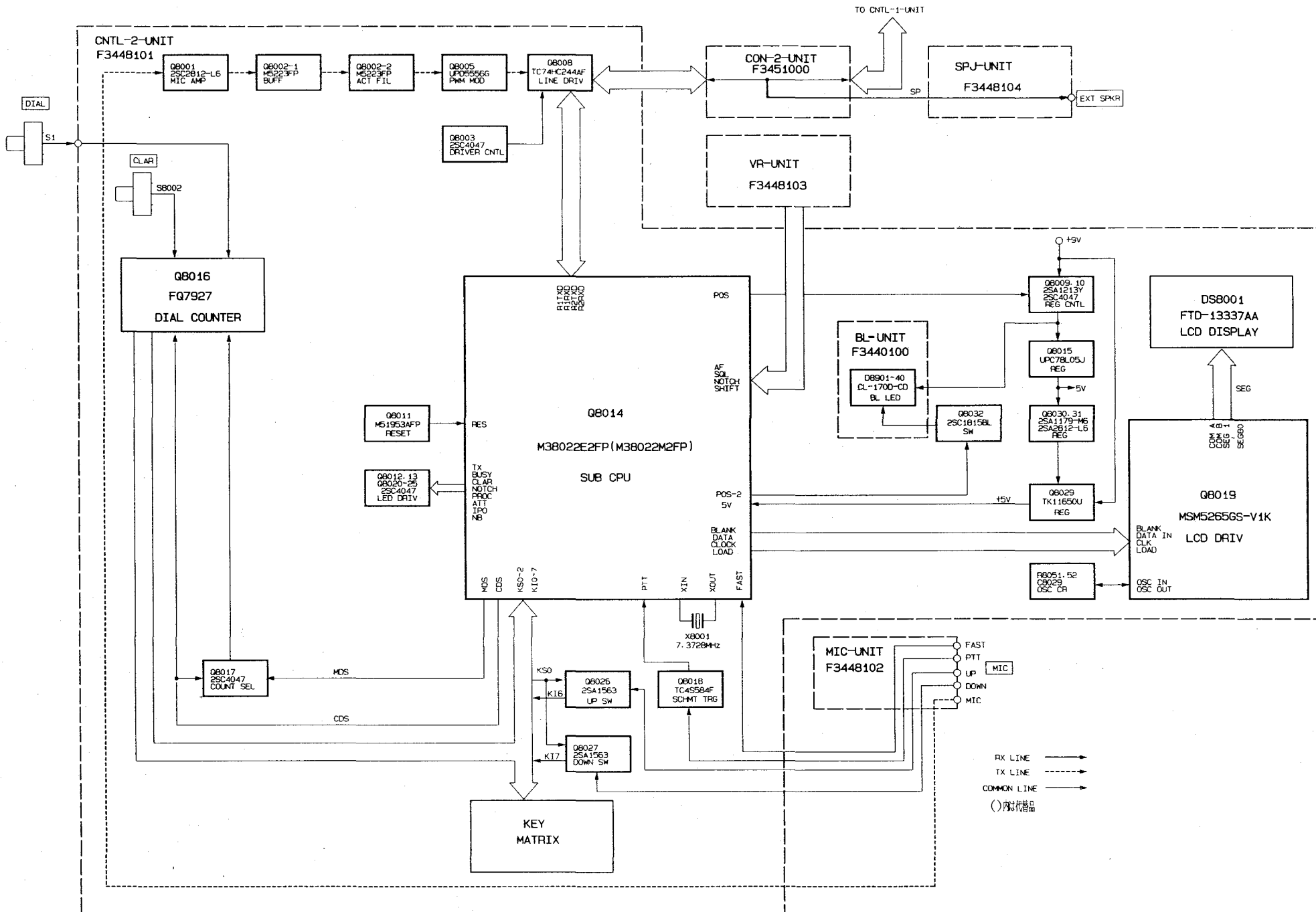

TUNER BLOCK DIAGRAM

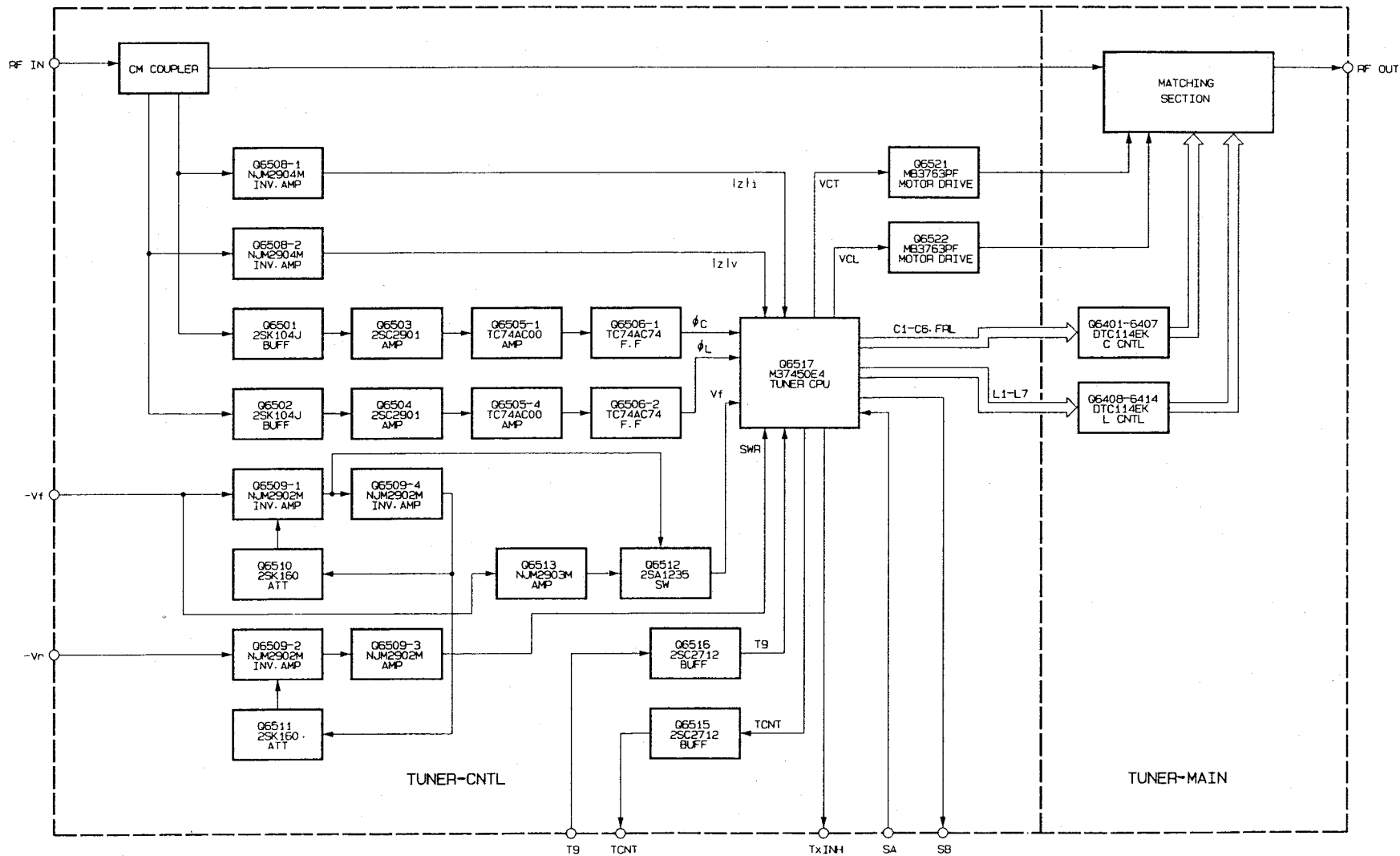

RF-UNIT
F325100C

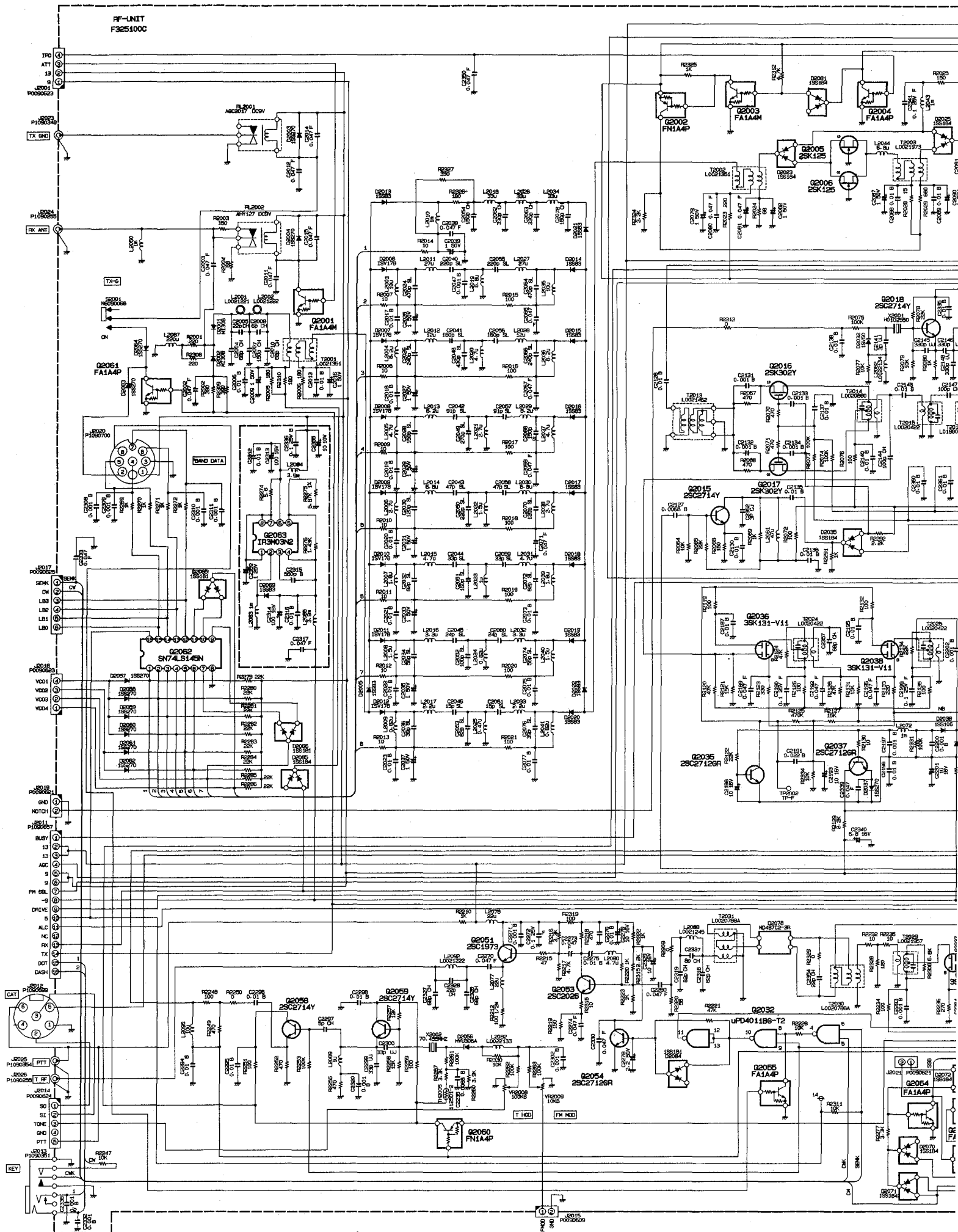

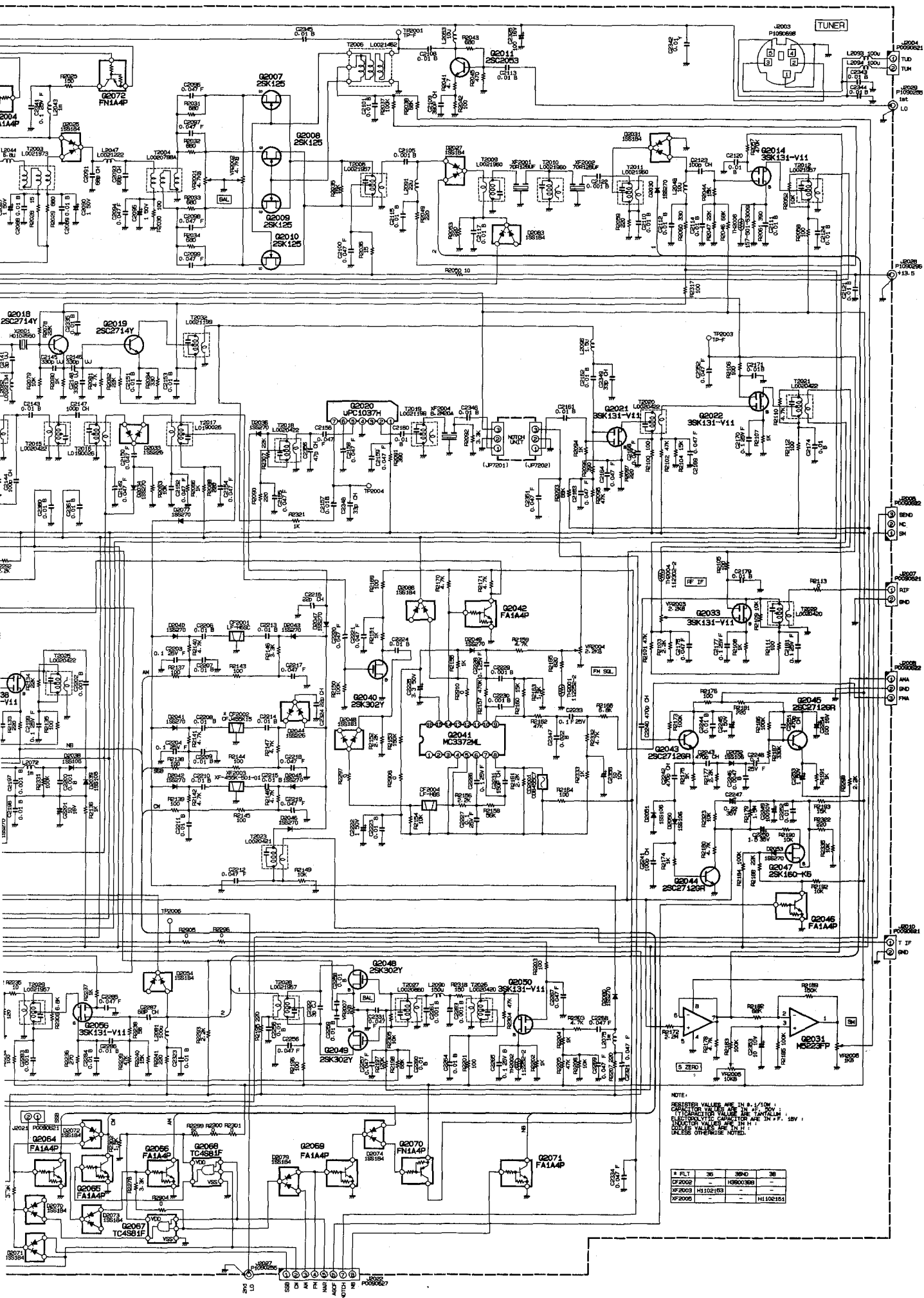

NOTE:
 REGISTER VALUE ARE IN 10%
 ELECTRIC VALUE ARE IN 10%
 ALL COMPONENTS ARE IN 10%
 PLEASE REFER TO THE NOTE

10K	36	30K	20
100K	100	100K	100
1000K	1000	1000K	1000
10000K	10000	10000K	10000

LOCAL-UNIT F3445000

VCG1
0.1-7.5M

VCG2
7.5-14.5M

VCG3
14.5-21.5M

VCG4
21.5-30.0M

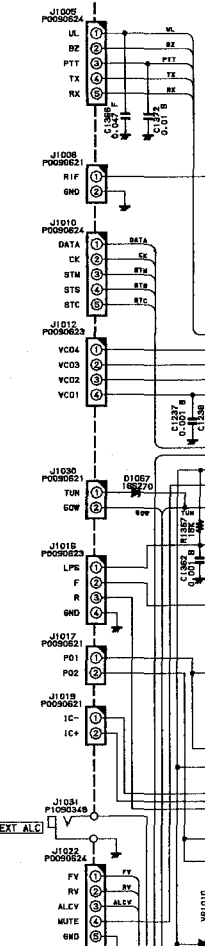

NOTE:
RESISTOR VALUES ARE IN Ω , $\frac{1}{10}\Omega$,
CAPACITOR VALUES ARE IN μF , pF , SOV ;
T₁ CAPACITOR VALUES ARE TANTALUM;
INDUCTOR VALUES ARE IN H,
UNLESS OTHERWISE NOTED.

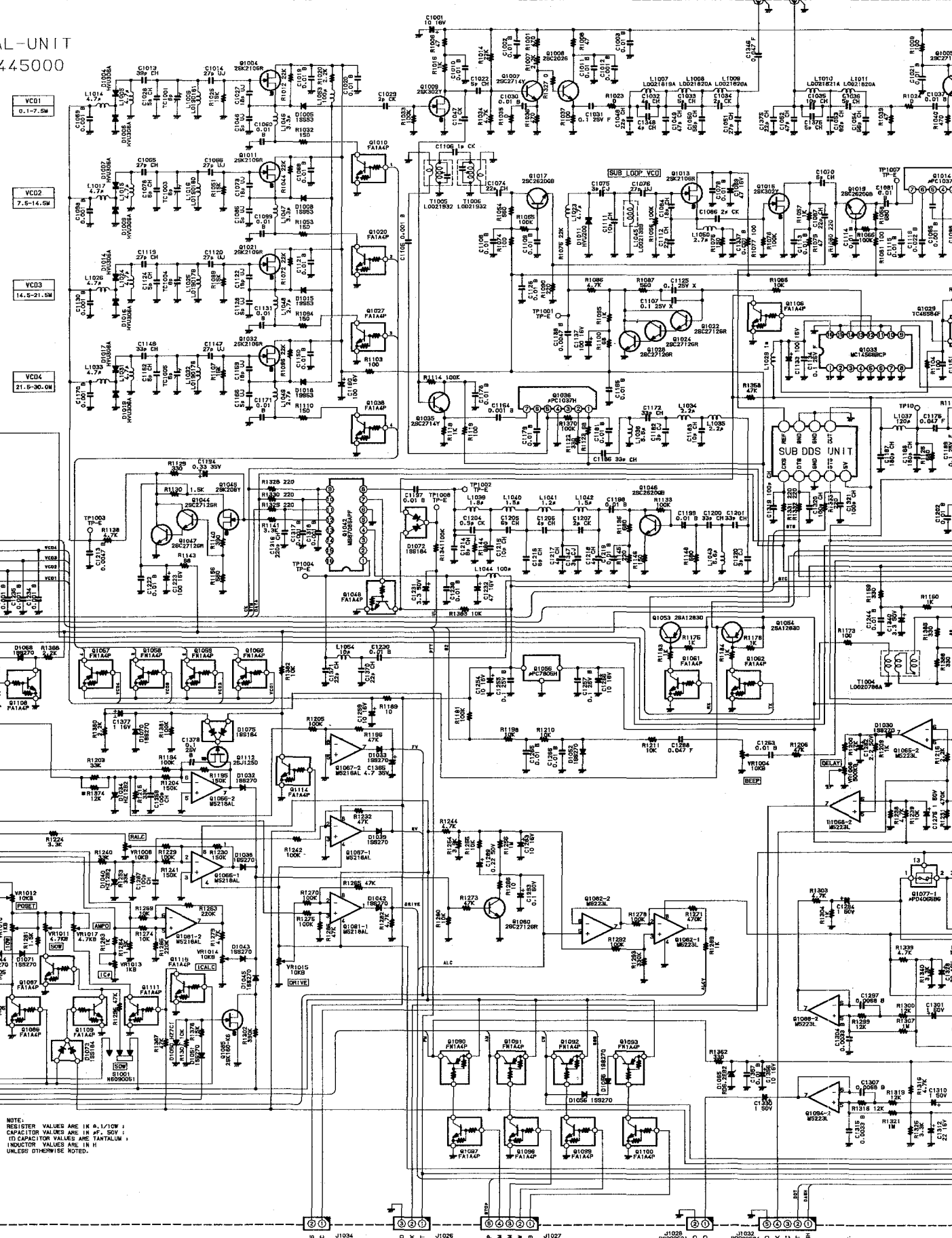

1ST LD
J1001
P109D235

2ND LD
J1003
P109D235

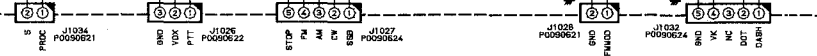

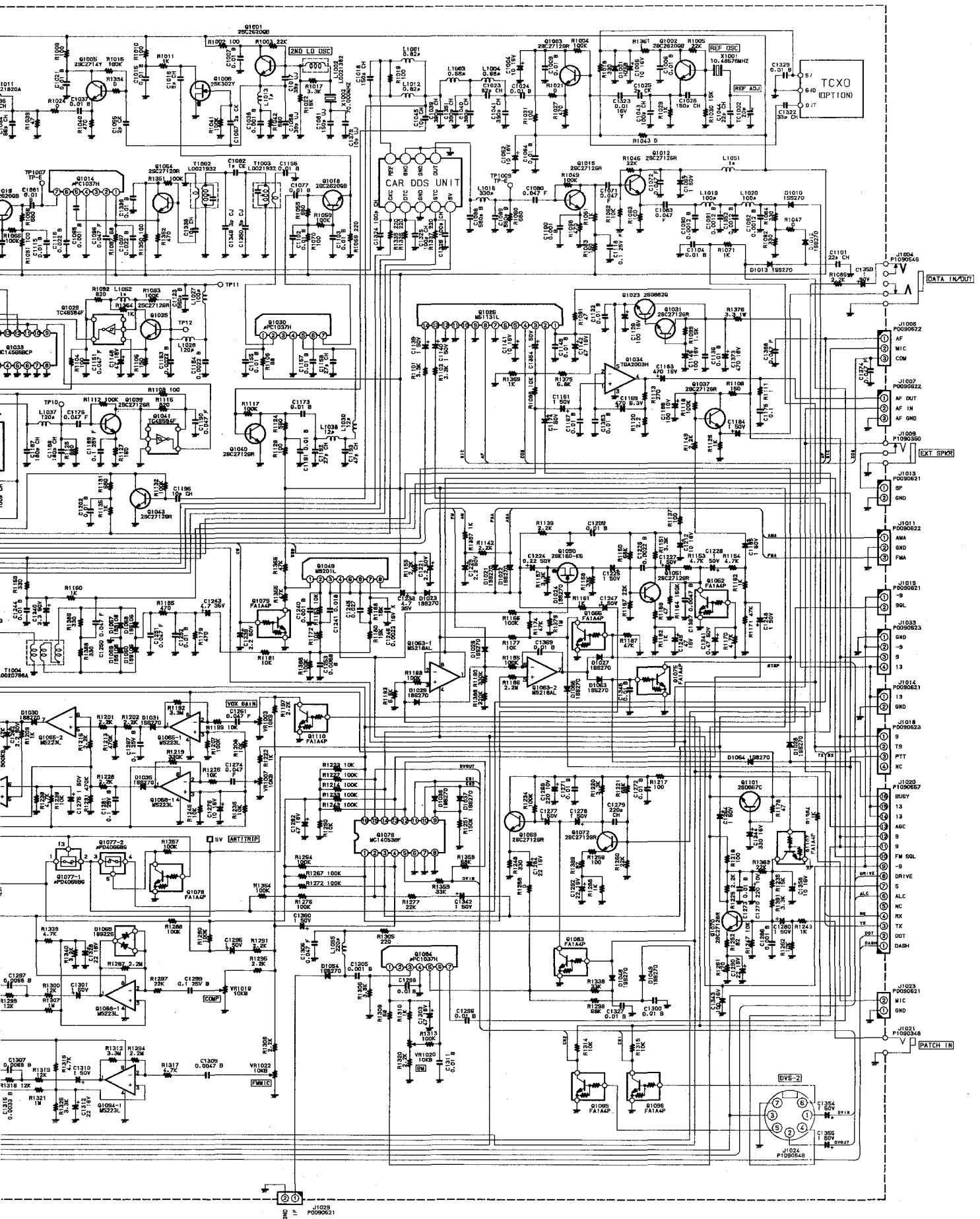

1011
21820A

1019
25200B

1023
TC4894AF

1028
TC4894AF

1030
TC4894AF

1033
TC4894AF

1036
TC4894AF

1037
P040090B

1039
P040090B

1040
P040090B

1041
P040090B

1042
P040090B

R1001 100

R1002 100

R1003 22K

R1004 100

R1005 100

R1006 100

R1007 100

R1008 100

R1009 100

R1010 100

R1011 100

R1012 100

R1013 100

R1014 100

R1015 100

R1016 100

R1017 100

R1018 100

R1019 100

R1020 100

R1021 100

R1022 100

R1023 100

R1024 100

R1025 100

R1026 100

R1027 100

R1028 100

R1029 100

R1030 100

R1031 100

R1032 100

R1033 100

R1034 100

R1035 100

R1036 100

R1037 100

R1038 100

R1039 100

R1040 100

R1041 100

R1042 100

R1043 100

R1044 100

R1045 100

R1046 100

R1047 100

R1048 100

R1049 100

R1050 100

R1051 100

R1052 100

R1053 100

R1054 100

R1055 100

R1056 100

R1057 100

R1058 100

R1059 100

R1060 100

R1061 100

R1062 100

R1063 100

R1064 100

R1065 100

R1066 100

R1067 100

R1068 100

R1069 100

R1070 100

R1071 100

R1072 100

R1073 100

R1074 100

R1075 100

R1076 100

R1077 100

R1078 100

R1079 100

R1080 100

R1081 100

R1082 100

R1083 100

R1084 100

R1085 100

R1086 100

R1087 100

R1088 100

R1089 100

R1090 100

R1091 100

R1092 100

R1093 100

R1094 100

R1095 100

R1096 100

R1097 100

R1098 100

R1099 100

R1100 100

R1101 100

R1102 100

R1103 100

R1104 100

R1105 100

R1106 100

R1107 100

R1108 100

R1109 100

R1110 100

R1111 100

R1112 100

R1113 100

R1114 100

R1115 100

R1116 100

R1117 100

R1118 100

R1119 100

R1120 100

R1121 100

R1122 100

R1123 100

R1124 100

R1125 100

R1126 100

R1127 100

R1128 100

R1129 100

R1130 100

R1131 100

R1132 100

R1133 100

R1134 100

R1135 100

R1136 100

R1137 100

R1138 100

R1139 100

R1140 100

R1141 100

R1142 100

R1143 100

R1144 100

R1145 100

R1146 100

R1147 100

R1148 100

R1149 100

R1150 100

R1151 100

R1152 100

R1153 100

R1154 100

R1155 100

R1156 100

R1157 100

R1158 100

R1159 100

R1160 100

R1161 100

R1162 100

R1163 100

R1164 100

R1165 100

R1166 100

R1167 100

R1168 100

R1169 100

R1170 100

R1171 100

R1172 100

R1173 100

R1174 100

R1175 100

R1176 100

R1177 100

R1178 100

R1179 100

R1180 100

R1181 100

R1182 100

R1183 100

R1184 100

R1185 100

R1186 100

R1187 100

R1188 100

R1189 100

R1190 100

R1191 100

R1192 100

R1193 100

R1194 100

R1195 100

R1196 100

R1197 100

R1198 100

R1199 100

R1200 100

R1201 100

R1202 100

R1203 100

R1204 100

R1205 100

R1206 100

R1207 100

R1208 100

R1209 100

R1210 100

R1211 100

R1212 100

R1213 100

R1214 100

R1215 100

R1216 100

R1217 100

R1218 100

R1219 100

R1220 100

R1221 100

R1222 100

R1223 100

R1224 100

R1225 100

R1226 100

R1227 100

R1228 100

R1229 100

R1230 100

R1231 100

R1232 100

R1233 100

R1234 100

R1235 100

R1236 100

R1237 100

R1238 100

R1239 100

R1240 100

R1241 100

R1242 100

R1243 100

R1244 100

R1245 100

R1246 100

R1247 100

R1248 100

R1249 100

R1250 100

R1251 100

R1252 100

R1253 100

R1254 100

R1255 100

R1256 100

R1257 100

R1258 100

R1259 100

R1260 100

R1261 100

R1262 100

R1263 100

R1264 100

R1265 100

R1266 100

R1267 100

R1268 100

R1269 100

R1270 100

R1271 100

R1272 100

R1273 100

R1274 100

R1275 100

R1276 100

R1277 100

R1278 100

CNTL-2-UNIT
F3448101

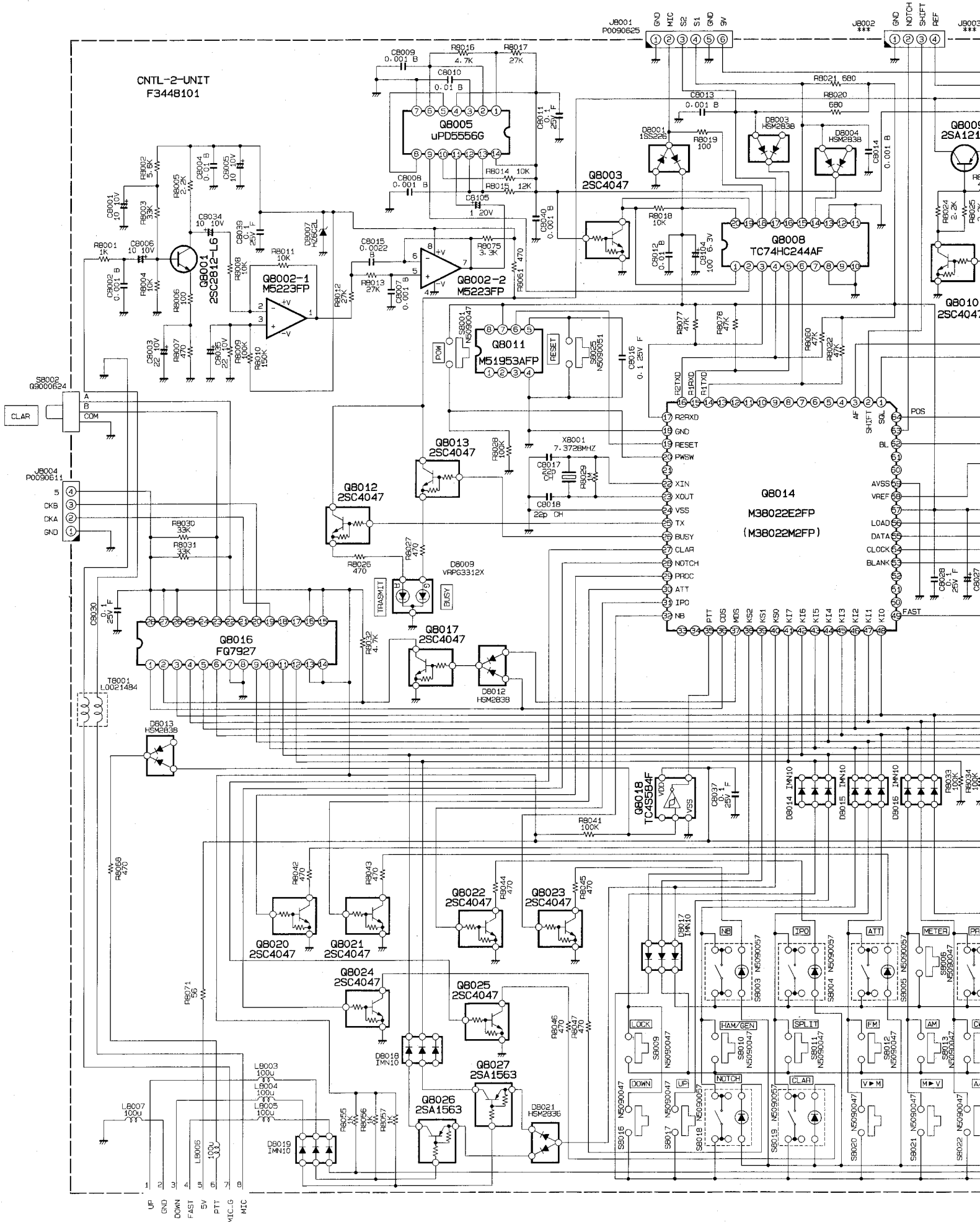

TUNER-CNTL-UNIT
F3247000B

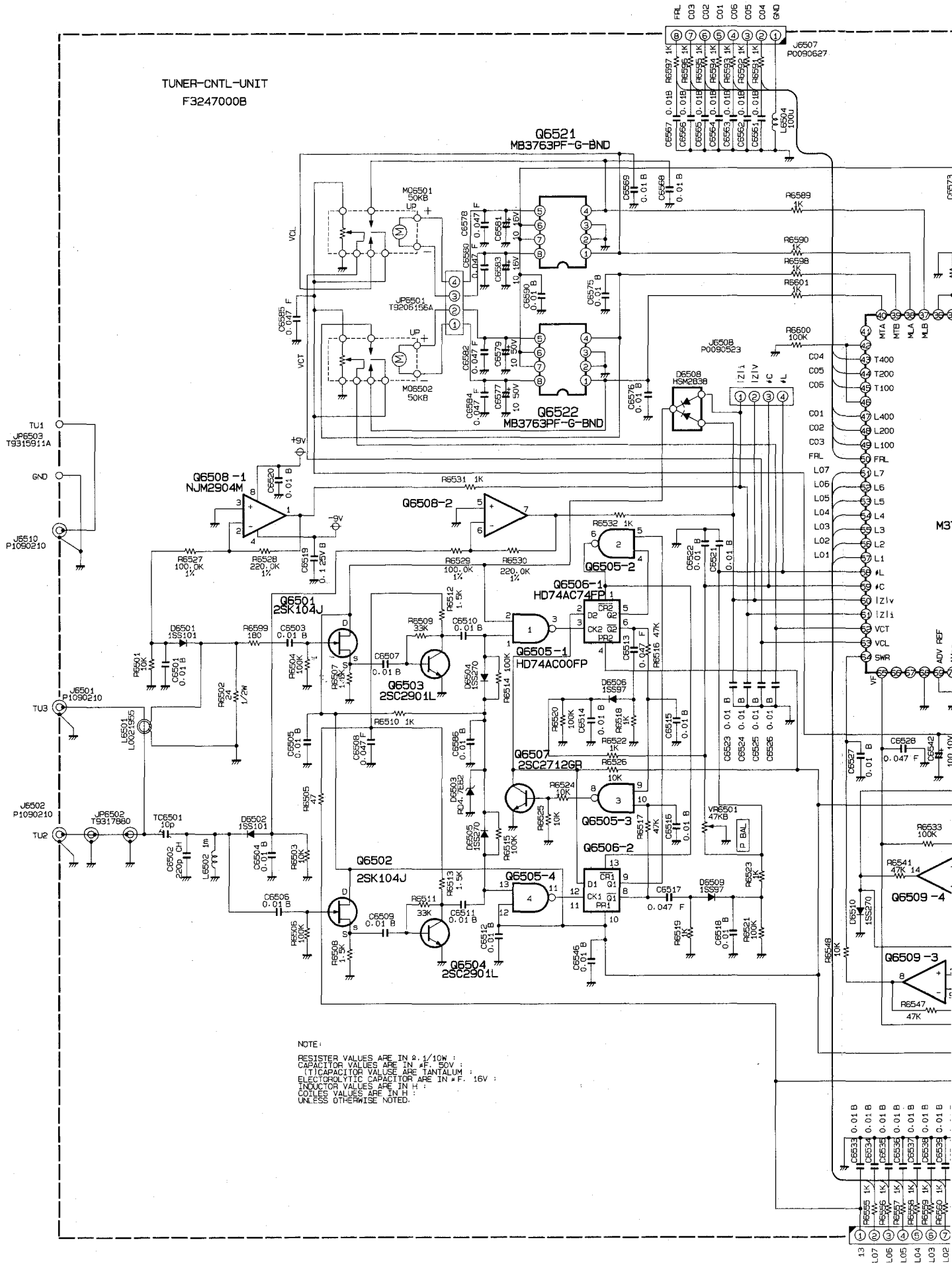

NOTE:
RESISTOR VALUES ARE IN μ , 1/10K ;
CAPACITOR VALUES ARE IN μ , F, 50V ;
TITICAPACITOR VALUE ARE TANTALUM ;
ELECTROLYTIC CAPACITOR ARE IN μ , F, 16V ;
INDUCTOR VALUES ARE IN H ;
COILS VALUES ARE IN H ;
UNLESS OTHERWISE NOTED.

- ① C6533 0.01B
- ② R6535 1K
- ③ C6534 0.01B
- ④ R6536 1K
- ⑤ C6535 0.01B
- ⑥ R6537 1K
- ⑦ C6536 0.01B
- ⑧ R6538 1K
- ⑨ C6537 0.01B
- ⑩ R6539 1K
- ⑪ C6538 0.01B
- ⑫ R6540 1K
- ⑬ C6539 0.01B

- ① J6507 P0090627
- ② C6567 0.01B
- ③ R6567 1K
- ④ C6568 0.01B
- ⑤ R6568 1K
- ⑥ C6569 0.01B
- ⑦ R6569 1K
- ⑧ C6570 0.01B
- ⑨ R6570 1K
- ⑩ C6571 0.01B
- ⑪ R6571 1K
- ⑫ C6572 0.01B
- ⑬ R6572 1K
- ⑭ C6573 0.01B
- ⑮ R6573 1K
- ⑯ C6574 0.01B
- ⑰ R6574 1K
- ⑱ C6575 0.01B
- ⑲ R6575 1K
- ⑳ C6576 0.01B
- ㉑ R6576 1K
- ㉒ C6577 0.01B
- ㉓ R6577 1K
- ㉔ C6578 0.01B
- ㉕ R6578 1K
- ㉖ C6579 0.01B
- ㉗ R6579 1K
- ㉘ C6580 0.01B
- ㉙ R6580 1K
- ㉚ C6581 0.01B
- ㉛ R6581 1K
- ㉜ C6582 0.01B
- ㉝ R6582 1K
- ㉞ C6583 0.01B
- ㉟ R6583 1K
- ㊱ C6584 0.01B
- ㊲ R6584 1K
- ㊳ C6585 0.01B
- ㊴ R6585 1K
- ㊵ C6586 0.01B
- ㊶ R6586 1K
- ㊷ C6587 0.01B
- ㊸ R6587 1K
- ㊹ C6588 0.01B
- ㊺ R6588 1K
- ㊻ C6589 0.01B
- ㊼ R6589 1K
- ㊽ C6590 0.01B
- ㊾ R6590 1K
- ㊿ C6591 0.01B
- Ⓚ R6591 1K
- Ⓛ C6592 0.01B
- Ⓜ R6592 1K
- Ⓨ C6593 0.01B
- Ⓩ R6593 1K
- ⓐ C6594 0.01B
- ⓑ R6594 1K
- ⓒ C6595 0.01B
- ⓓ R6595 1K
- ⓔ C6596 0.01B
- ⓕ R6596 1K
- ⓖ C6597 0.01B
- ⓗ R6597 1K
- ⓘ C6598 0.01B
- ⓙ R6598 1K
- ⓚ C6599 0.01B
- ⓛ R6599 1K
- ⓜ C6600 0.01B
- ⓝ R6600 1K
- ⓞ C6601 0.01B
- ⓟ R6601 1K
- ⓠ C6602 0.01B
- ⓡ R6602 1K
- ⓢ C6603 0.01B
- ⓣ R6603 1K
- ⓤ C6604 0.01B
- ⓥ R6604 1K
- ⓦ C6605 0.01B
- ⓧ R6605 1K
- ⓨ C6606 0.01B
- ⓩ R6606 1K
- ⓪ C6607 0.01B
- ⓫ R6607 1K
- ⓬ C6608 0.01B
- ⓭ R6608 1K
- ⓮ C6609 0.01B
- ⓯ R6609 1K
- ⓰ C6610 0.01B
- ⓱ R6610 1K
- ⓲ C6611 0.01B
- ⓳ R6611 1K
- ⓴ C6612 0.01B
- ⓵ R6612 1K
- ⓶ C6613 0.01B
- ⓷ R6613 1K
- ⓸ C6614 0.01B
- ⓹ R6614 1K
- ⓺ C6615 0.01B
- ⓻ R6615 1K
- ⓼ C6616 0.01B
- ⓽ R6616 1K
- ⓾ C6617 0.01B
- ⓿ R6617 1K
- Ⓚ C6618 0.01B
- Ⓛ R6618 1K
- Ⓜ C6619 0.01B
- Ⓨ R6619 1K
- Ⓩ C6620 0.01B
- ⓐ R6620 1K
- ⓑ C6621 0.01B
- ⓒ R6621 1K
- ⓓ C6622 0.01B
- ⓔ R6622 1K
- ⓕ C6623 0.01B
- ⓖ R6623 1K
- ⓗ C6624 0.01B
- ⓘ R6624 1K
- ⓙ C6625 0.01B
- ⓚ R6625 1K
- ⓛ C6626 0.01B
- ⓜ R6626 1K
- ⓝ C6627 0.01B
- ⓞ R6627 1K
- ⓟ C6628 0.01B
- ⓠ R6628 1K
- ⓡ C6629 0.01B
- ⓢ R6629 1K
- ⓣ C6630 0.01B
- ⓤ R6630 1K
- ⓥ C6631 0.01B
- ⓦ R6631 1K
- ⓧ C6632 0.01B
- ⓨ R6632 1K
- ⓩ C6633 0.01B
- ⓪ R6633 1K
- ⓫ C6634 0.01B
- ⓬ R6634 1K
- ⓭ C6635 0.01B
- ⓮ R6635 1K
- ⓯ C6636 0.01B
- ⓰ R6636 1K
- ⓱ C6637 0.01B
- ⓲ R6637 1K
- ⓳ C6638 0.01B
- ⓴ R6638 1K
- ⓵ C6639 0.01B
- ⓶ R6639 1K
- ⓷ C6640 0.01B
- ⓸ R6640 1K
- ⓹ C6641 0.01B
- ⓺ R6641 1K
- ⓻ C6642 0.01B
- ⓼ R6642 1K
- ⓽ C6643 0.01B
- ⓿ R6643 1K
- Ⓚ C6644 0.01B
- Ⓛ R6644 1K
- Ⓜ C6645 0.01B
- Ⓨ R6645 1K
- Ⓩ C6646 0.01B
- ⓐ R6646 1K
- ⓑ C6647 0.01B
- ⓒ R6647 1K
- ⓓ C6648 0.01B
- ⓔ R6648 1K
- ⓕ C6649 0.01B
- ⓖ R6649 1K
- ⓗ C6650 0.01B
- ⓘ R6650 1K
- ⓙ C6651 0.01B
- ⓚ R6651 1K
- ⓛ C6652 0.01B
- ⓜ R6652 1K
- ⓝ C6653 0.01B
- ⓞ R6653 1K
- ⓟ C6654 0.01B
- ⓠ R6654 1K
- ⓡ C6655 0.01B
- ⓢ R6655 1K
- ⓣ C6656 0.01B
- ⓤ R6656 1K
- ⓥ C6657 0.01B
- ⓦ R6657 1K
- ⓧ C6658 0.01B
- ⓨ R6658 1K
- ⓩ C6659 0.01B
- ⓪ R6659 1K
- ⓫ C6660 0.01B
- ⓬ R6660 1K
- ⓭ C6661 0.01B
- ⓮ R6661 1K
- ⓯ C6662 0.01B
- ⓰ R6662 1K
- ⓱ C6663 0.01B
- ⓲ R6663 1K
- ⓳ C6664 0.01B
- ⓴ R6664 1K
- ⓵ C6665 0.01B
- ⓶ R6665 1K
- ⓷ C6666 0.01B
- ⓸ R6666 1K
- ⓹ C6667 0.01B
- ⓺ R6667 1K
- ⓻ C6668 0.01B
- ⓼ R6668 1K
- ⓽ C6669 0.01B
- ⓿ R6669 1K
- Ⓚ C6670 0.01B
- Ⓛ R6670 1K
- Ⓜ C6671 0.01B
- Ⓨ R6671 1K
- Ⓩ C6672 0.01B
- ⓐ R6672 1K
- ⓑ C6673 0.01B
- ⓒ R6673 1K
- ⓓ C6674 0.01B
- ⓔ R6674 1K
- ⓕ C6675 0.01B
- ⓖ R6675 1K
- ⓗ C6676 0.01B
- ⓘ R6676 1K
- ⓙ C6677 0.01B
- ⓚ R6677 1K
- ⓛ C6678 0.01B
- ⓜ R6678 1K
- ⓝ C6679 0.01B
- ⓞ R6679 1K
- ⓟ C6680 0.01B
- ⓠ R6680 1K
- ⓡ C6681 0.01B
- ⓢ R6681 1K
- ⓣ C6682 0.01B
- ⓤ R6682 1K
- ⓥ C6683 0.01B
- ⓦ R6683 1K
- ⓧ C6684 0.01B
- ⓨ R6684 1K
- ⓩ C6685 0.01B
- ⓪ R6685 1K
- ⓫ C6686 0.01B
- ⓬ R6686 1K
- ⓭ C6687 0.01B
- ⓮ R6687 1K
- ⓯ C6688 0.01B
- ⓰ R6688 1K
- ⓱ C6689 0.01B
- ⓲ R6689 1K
- ⓳ C6690 0.01B
- ⓴ R6690 1K
- ⓵ C6691 0.01B
- ⓶ R6691 1K
- ⓷ C6692 0.01B
- ⓸ R6692 1K
- ⓹ C6693 0.01B
- ⓺ R6693 1K
- ⓻ C6694 0.01B
- ⓼ R6694 1K
- ⓽ C6695 0.01B
- ⓿ R6695 1K
- Ⓚ C6696 0.01B
- Ⓛ R6696 1K
- Ⓜ C6697 0.01B
- Ⓨ R6697 1K
- Ⓩ C6698 0.01B
- ⓐ R6698 1K
- ⓑ C6699 0.01B
- ⓒ R6699 1K
- ⓓ C6700 0.01B
- ⓔ R6700 1K

YAESU
Performance without compromise.SM

Copyright © 1994
Yaesu Musen Co., Ltd.
All rights reserved.

EJWG57502(408) DA